

## Specifications

<b>Contact Design:</b>	One normally open (N.O.) and one normally closed (N.C.), isolated contacts
<b>Contact Ratings:</b>	8A @ 110 VAC resistive, 5Amps @ 30 VDC resistive
<b>Contact Life:</b>	Mechanical - 10 million operations. Electrical - 100,000 operations minimum at rated load
<b>Electronics Module:</b>	Solid state components epoxy encapsulated in a black nylon shell
<b>Supply Voltage:</b>	24 VAC, 115 VAC or 230 VAC models +10% -15%, 50/60 Hz.
<b>Supply Current:</b>	Relays energized - 1.7 VA.
<b>Secondary Circuit:</b>	17XXX0 - 13 VAC RMS voltage on probes, 4 mA (nominal) 17HXXX0 - 13 VDC RMS voltage on probes, 4 MA (nominal)
<b>Sensitivity:</b>	Models operate from 0-470,000 ohms maximum specific resistance (factory set)
<b>Temperature:</b>	-40° to 150° F ambient.
<b>Terminals:</b>	Size 6 pan head screws with captivated wire clamping plate.
<b>Listings:</b>	FM File #1G9A1.AX - Approved for use in Class I or II, Division 1, Groups A-G hazardous atmospheres.



## Warrick® Series 17 Controls Installation and Operation Bulletin

Form 170  
Sheet P/N 7800578  
Rev. F



This bulletin should be used by experienced personnel as a guide to the installation of Series 17. Selection or installation of equipment should always be accompanied by competent technical assistance. We encourage you to contact Gems Sensors or its local representative if further information is required. **Important: Completely read and thoroughly understand these instructions before proceeding to install and wire the control.**

When installed according to these instructions, the sensing circuit is intrinsically safe for Class I and II, Division 1, Groups A, B, C, D, E, F and G. **Electrical equipment connected to associated apparatus should not exceed maximum voltage marked on product.**

### Location:

The control must be situated in a non-hazardous area where an explosive atmosphere will not exist at any time.

### Wiring:

- Intrinsically safe wiring must be kept separate from non-intrinsically safe wiring.
- Intrinsically safe and non-intrinsically safe wiring may occupy the same enclosure or raceway if they are at least 2 inches (50mm) apart and separately tied down. Inside panels, field wiring terminals for intrinsically safe circuits must be separated by at least 2 inches (50 mm) from non-intrinsically safe terminals.
- Wire the control device(s) to the Series 17 relay as shown in the specific application wiring diagram on the inside pages. A separate rigid metallic conduit should be used to enclose the conductors of the intrinsically safe control circuit.
- An approved seal should be used at the point where the intrinsically safe control circuit wiring enters the hazardous area.

For intrinsically safe output wiring, use #14 or #16 AWG type MTW or THHN wire. By using these wire types in conjunction with the following distance recommendations, you will not exceed the maximum capacitance for field wiring.

**Use the following chart as a guide for maximum wire runs for differential level service (3-wire) field wiring.**

Model	Sensitivity K-ohms/ Probe Voltage	*Max Distance (FT)		Sensitivity Resistor Ohm Valve
		Primary Voltage 120, 240 VAC	Primary Voltage 24 VAC	
17XXC0	3.3/A.C.	5000	1000	Jumper
17XXD0	4.7/A.C.	3500	1000	4.7K
17XXE0	10/A.C.	1750	1000	10.0K
17XXF0	22/A.C.	1000	1000	22K
17XXG0	47/A.C.	500	500	47K
17XXH0	100/A.C.	250	250	100K
17XXJ0	220/A.C.	100	100	220K
17XXK0	470/A.C.	50	50	470K
17HXXX0	D.C.	5000	1000	Jumper

\* Longer distances may be possible. Consult factory for assistance.

### Grounding:

Both mounting tabs provide an electrical connection for earth grounding between the control's internal solid state circuitry and the enclosure chassis. To insure proper grounding, use only metal screws and lock washers when mounting this control.

One of the two grounding terminals provided on the intrinsically safe output terminal strip must be connected as reference to the same conductive media presented to terminals "H" and "L" (see applicable wiring diagram on inside pages). Terminal G1 on the supply line/load side terminal strip is a redundant system ground terminal and should be connected to the earth ground buss of the control's AC supply line feeder.

### Note:

- Intrinsically safe terminals can be connected to any non-energy generating or storing switch device such as a pushbutton, limit or float type switch or any Warrick electrode and fitting assembly.
- To prevent electrical shock from supply line/load side powered connections, the Series 17 should be mounted in a tool accessible enclosure of proper NEMA rated integrity.
- For additional guidance on "Hazardous Location Installation" and "Intrinsically Safe Devices", consult ANSI/ISA standard RP 12-6 or NEC articles 500-516.

### Ordering Information:

**17 X X X X**

- Enclosure: 0- none, 1- NEMA 1, 4- NEMA 4, 7 - NEMA 7
- Sensitivity (Ohms): C- 3.3K D- 4.7K, E- 10K, F- 22K, G- 47K, H- 100K, J- 220K, K- 470K
- Voltage: 50/60HZ, 1- 120 VAC, 2 - 240 VAC, 3 - 24 VAC
- Mode of Operation: A- Direct, B- Inverse

**17H X X X X**

- Enclosure: 0- none, 1- NEMA 1, 4- NEMA 4, 7- NEMA 7
- Sensitivity (Ohms): C- 3.3K D- 4.7K, E- 10K, F- 22K, G- 47K, H- 100K, J- 220K, K- 470K
- Voltage: 1- 120 VAC, 2 - 240 VAC, 3 - 24 vac
- Mode of Operation: A- Direct, B- Inverse
- D.C. on probe sensing circuit

- 1) Connect terminals 1 & 2 to appropriate VAC supply line
- 2) Install sensitivity resistor between terminals RH & H and metallic jumper between terminals H and L. The resistor value determines the control sensitivity. **(See chart on Pg. 1)**

- 3) Connect terminal L to the electrode
- 4) Wire contacts 3-4 normally open and 5 -6 normally closed into load circuit as required

Terminal G must be grounded to the tank if metallic. When the tank is non-metallic, terminal G must be connected to an additional electrode of length equal to the longest electrode.

**Note:** Jumper and resistors must be installed as shown to insure proper operation.

### Single Level Service: Conductance Actuated

**Note:** Jumper and resistor\* must be installed as shown to insure proper operation.  
\*Jumper is used in lieu of resistor for control sensitivity of 3300 ohms (c).

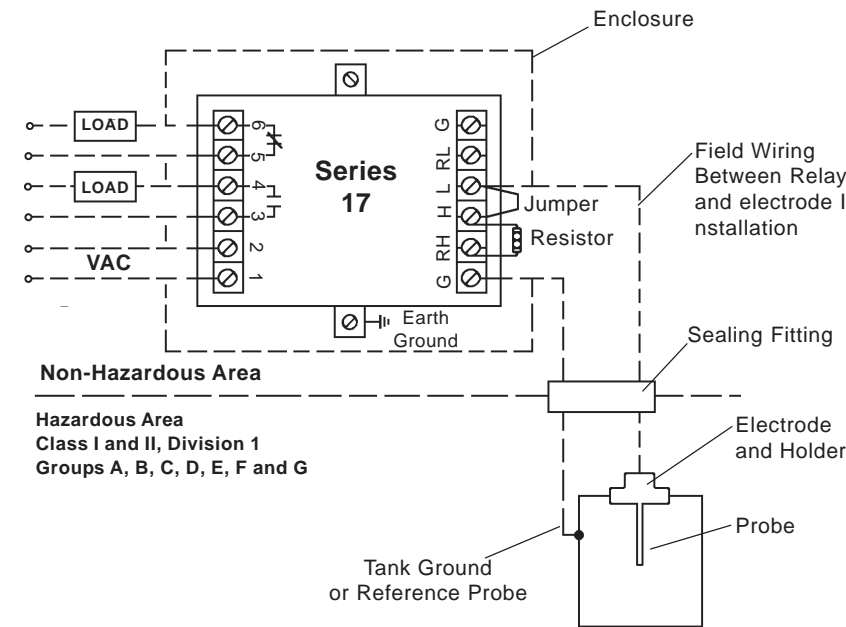
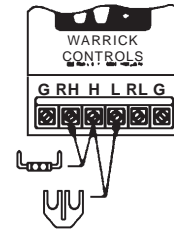

- 1) Connect terminals 1 & 2 to appropriate VAC supply line.
- 2) Install metallic jumper between terminals RH & H and terminals H & L.
- 3) Wire contacts 3-4 normally open and 5 -6 normally closed into load circuit as required.
- 4) Connect the pilot contact to terminals G and L.

**Note:** Jumper and resistors must be installed as shown to insure proper operation.

### Single Input (Non-Latching): Pilot Contact Actuated

**Note:** Jumpers must be installed as shown to insure proper operation.

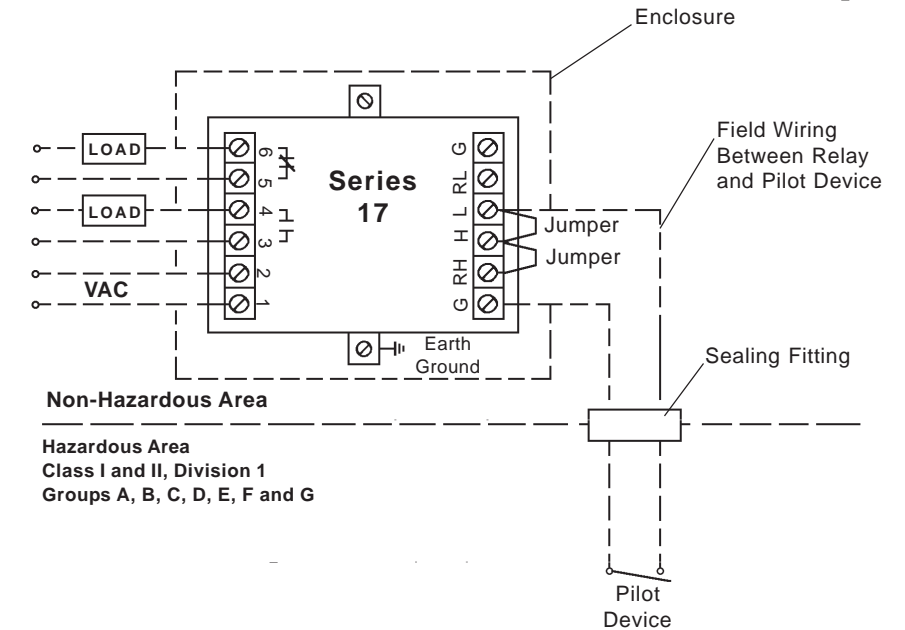
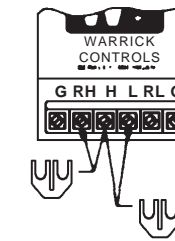

- 1) Connect terminals 1 & 2 to appropriate VAC supply line
- 2) Install sensitivity resistor between terminals RH & H and RL & L. The resistor value determines the control sensitivity. **(See chart on Pg. 1)** Both resistors must be of equal value.

- 3) Connect terminal H to high electrode and terminal L to low electrode
- 4) Wire contacts 3-4 normally open and 5 -6 normally closed into load circuit as required

Terminal G must be grounded to the tank if metallic. When the tank is non-metallic, terminal G must be connected to an additional electrode of length equal to the longest electrode.

**Note:** Jumper and resistors must be installed as shown to insure proper operation.

### Differential Level Service: Conductance Actuated

**Note:** Resistor\* must be installed as shown to insure proper operation.  
\*Jumpers are used in lieu of resistor for control sensitivity of 3300 ohms (c).

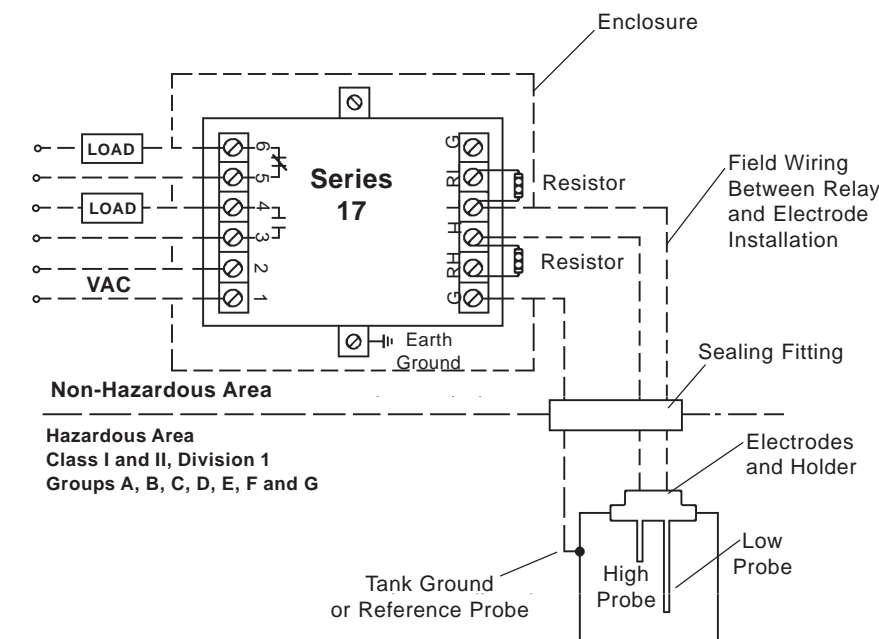
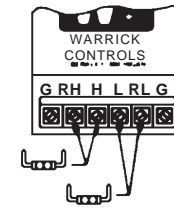

- 1) Connect terminals 1 & 2 to appropriate VAC supply line.
- 2) Install metallic jumpers between terminals RH & H and terminals RL & L.
- 3) Wire contacts 3-4 normally open and 5 -6 normally closed into load circuit as required.
- 4) Connect the latch pilot contact to terminals G & H and the unlatch pilot contact to terminals G & L.

**Note:** Jumper and resistors must be installed as shown to insure proper operation.

### Dual Input (Latching): Pilot Contact Actuated

**Note:** Jumpers must be installed as shown to insure proper operation.

