

Series 67 Multi-Function Control Duplex Pump System Control

- ▶ Inverse or Direct Acting, Field Selectable
- ▶ Solid State Reliability
- ▶ Compact Size
- ▶ Four Independent Channels – 2 Single, 2 Differential
- ▶ Field Adjustable, Sensitivity and Mode Selection
- ▶ LED Channel Indicators
- ▶ Built-in Silence/Acknowledge Circuit
- ▶ U.L. “Intrinsically Safe”

Warrick's Series 67 four channel level control is an ideal solution to liquid level problems in hazardous applications for the sewage, waste water, chemical and groundwater remediation industries.

Connected to floats or conductance probes this versatile control provides simplex or duplex pump/solenoid valve control; automatic or manual alternation; high and/or low level alarms with silence/acknowledge capabilities.

The Series 67 can be used in hazardous applications as an intrinsically safe interface to non-powered contacts and sensors such as push button operators, limit, temperature, pressure and vacuum switches.

Designed for hazardous applications, its low cost, integrated features and compact size also make it ideal for non-hazardous applications.

Specifications

Contact Design	Standard N.O., N.C. (form C); Optional N.O., N.C.
Contact Rating (30VDC, 120/240VAC)	10 amp (style C); 5 amp (style A)
Primary Voltage	120 VAC, 50/60 Hz
Secondary Voltage	12 VAC @ 6mA RMS
Sensitivity	4.7K - 100K ohms maximum specific resistance, factory set
Temperature	-40°F to +150°F (-40°C to +65°C)
Approvals	U.L. 913 File # E44570

How to Order

Use the **Bold** characters from the chart below to construct a product code.

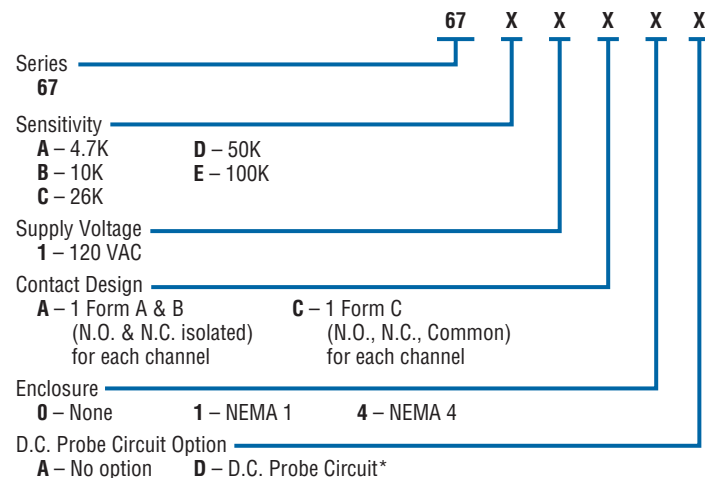

*Eliminates short cycles

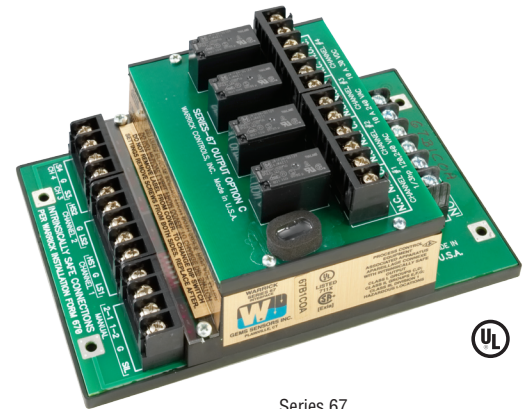

Series 67

Applications

- Hazardous Atmospheres
- Multiple Functions
- Simplex or Duplex
- High/Low Level Alarms
- Auto or Manual Alternation
- Pump/Solenoid Valves
- Sewage Lift Stations
- Wastewater Treatment
- Chemical Plants
- Groundwater Remediation

Dimensions

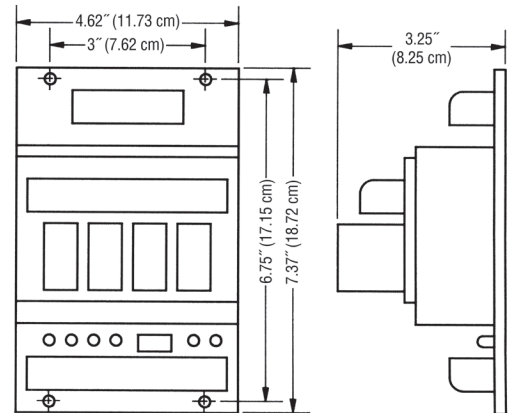

Wiring

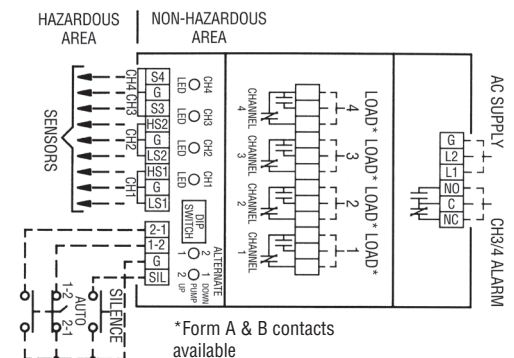

See Our Interstitial Tank Monitoring Products on page A-22.

