



McDonnell & Miller

Installation & Maintenance
Instructions
MM-217(I)

Series 150S and 157S



(Snap Switch, All Models except 157S-RB-P)

Low Water Cut-Off/Pump Controllers For Steam Boilers and Other Level Control Applications

Typical Applications:

- Primary or secondary pump controller/
low water fuel cut-off
for steam boilers
- Motorized valve controller
- Low water cut-off
- High water cut-off
- Alarm actuator

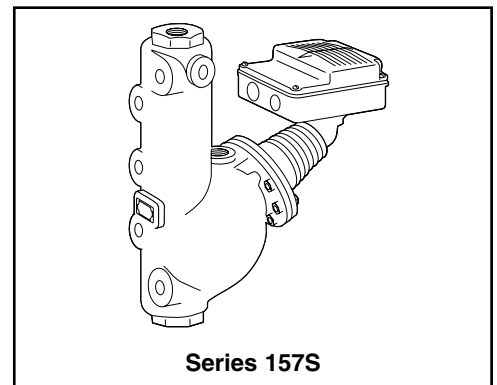
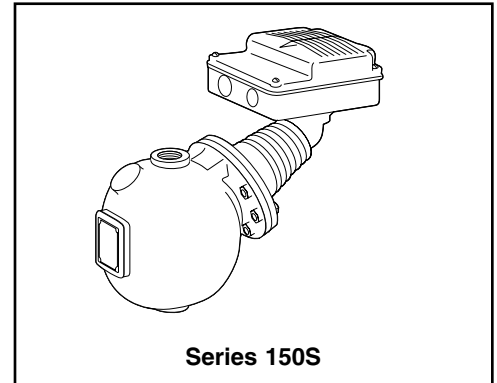

WARNING

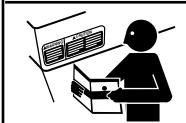

- Before using this product read and understand instructions.
 - Save these instructions for future reference.
 - All work must be performed by qualified personnel trained in the proper application, installation, and maintenance of plumbing, steam, and electrical equipment and/or systems in accordance with all applicable codes and ordinances.
 - To prevent serious burns, the boiler must be cooled to 80°F (27°C) and the pressure must be 0 psi (0 bar) before servicing.
 - To prevent electrical shock, turn off the electrical power before making electrical connections.
 - This low water cut-off must be installed in series with all other limit and operating controls installed on the boiler. After installation, check for proper operation of all of the limit and operating controls, before leaving the site.
 - We recommend that secondary (redundant) Low Water Cut-Off controls be installed on all steam boilers with heat input greater than 400,000 BTU/hour or operating above 15 psi of steam pressure. At least two controls should be connected in series with the burner control circuit to provide safety redundancy protection should the boiler experience a low water condition. Moreover, at each annual outage, the low water cut-offs should be dismantled, inspected, cleaned, and checked for proper calibration and performance.
 - To prevent serious personal injury from steam blow down, connect a drain pipe to the control opening to avoid exposure to steam discharge.
 - To prevent a fire, do not use this low water cut-off to switch currents over 7.4A, 1/3 Hp at 120 VAC or 3.7A, 1/3 Hp at 240 VAC, unless a starter or relay is used in conjunction with it.
- Failure to follow this warning could cause property damage, personal injury or death.

OPERATION

Maximum Pressure: 150 psi (10.5 kg/cm²)

Electrical Ratings

Voltage	Pump Circuit Rating (Amperes)		Pilot Duty
	Full Load	Locked Rotor	
120 VAC	7.4	44.4	345 VA at
240 VAC	3.7	22.2	120 or 240 VAC

Alarm Circuit Rating	
Voltage	Amps
120 VAC	1
240 VAC	1/2

Motor Horsepower	
Voltage	Hp
120 VAC	1/3
240 VAC	1/3

Enclosure rating: NEMA 1 General Purpose

Settings and Differential Pressures

Values are $\pm 1/8"$ (3.2mm).

Series 150S, 157S

Pressure	Setting	Approximate Distance Above Cast Line In. (mm)	Differential In. (mm)
0 psi (0 kg/cm ²)	Pump Off	15/16 (24)	5/16 (8)
	Pump On	5/8 (16)	
	Burner On	5/8 (16)	3/8 (16)
	Burner Off	1/4 (6.4)	
150 psi (10.5 kg/cm ²)	Pump Off	1 3/8 (41)	3/4 (19)
	Pump On	5/8 (16)	
	Burner On	7/8 (22)	7/8 (22)
	Burner Off	0 (0)	

150 psi (10.5 kg/cm²) Levels

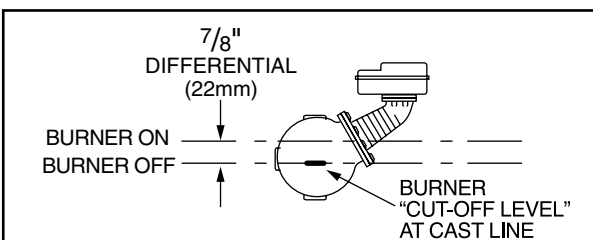
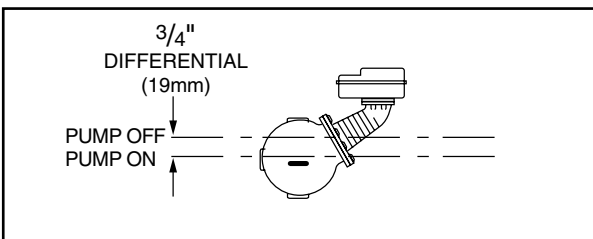
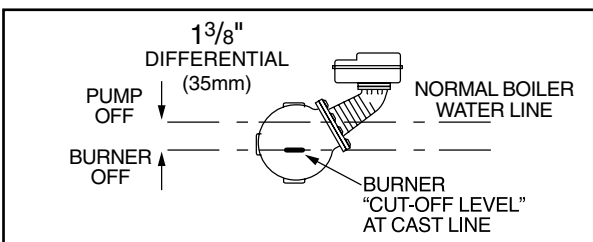

Model 150S-MD, and 157S-MD

Pressure	Setting	Approximate Distance Above Cast Line In. (mm)	Differential In. (mm)
0 psi (0 kg/cm ²)	Pump Off	15/16 (24)	3/8 (16)
	Pump On	9/16 (14)	
	Burner Off	0 (0)	N/A
150 psi (10.5 kg/cm ²)	Pump Off	1 7/16 (37)	3/4 (19)
	Pump On	11/16 (17)	
	Burner Off	- 3/8 (-16)	N/A

150 psi (10.5 kg/cm²) Levels

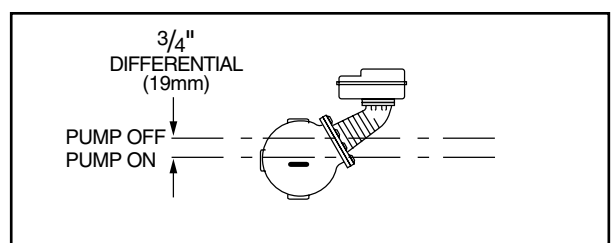
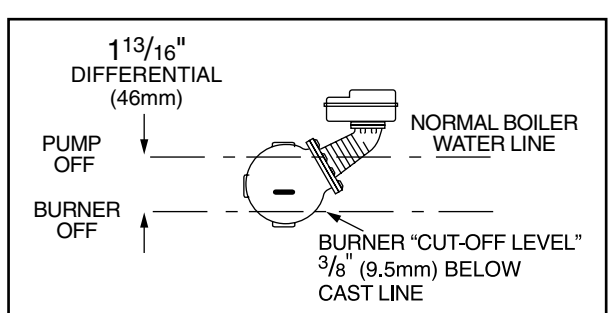

Settings and Differential Pressures (continued)

Values are $\pm 1/8$ " (3.2mm).

Model 158S

Pressure	Setting	Approximate Distance Above Cast Line In. (mm)	Differential In. (mm)
0 psi (0 kg/cm²)	Motorized Valve Closed	15/16 (24)	5/16 (8)
	Motorized Valve Open	5/8 (16)	
	Burner On	5/8 (16)	3/8 (16)
	Burner Off	1/4 (6.4)	
150 psi (10.5 kg/cm²)	Motorized Valve Closed	13/8 (41)	3/4 (19)
	Motorized Valve Open	5/8 (16)	
	Burner On	7/8 (22)	7/8 (22)
	Burner Off	0 (0)	

150 psi (10.5 kg/cm²) Levels

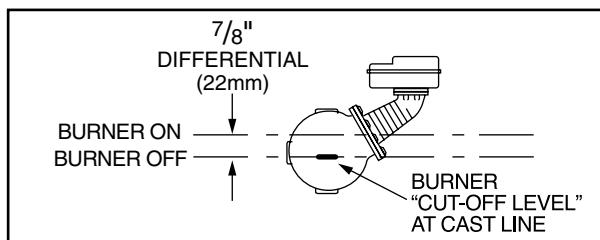
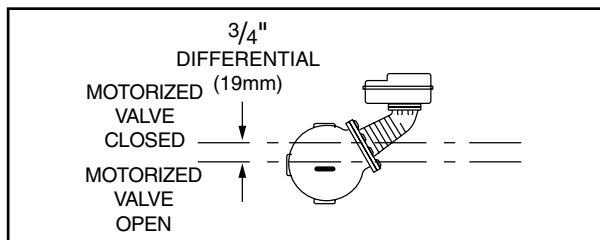
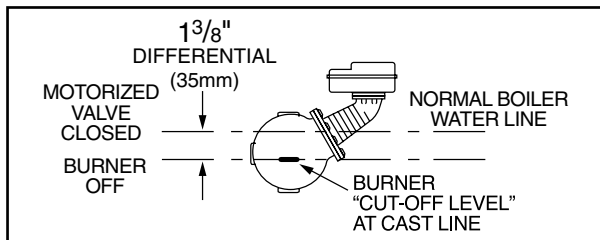

NOTE: Due to the slower operation of some motorized valves, complete valve opening or closing will occur at slightly different levels than indicated above.

Model 158S-MD

Pressure	Setting	Approximate Distance Above Cast Line In. (mm)	Differential In. (mm)
0 psi (0 kg/cm²)	Pump Off	15/16 (24)	3/8 (16)
	Pump On	9/16 (14)	
	Burner Off	0 (0)	N/A
150 psi (10.5 kg/cm²)	Pump Off	17/16 (37)	3/4 (19)
	Pump On	11/16 (17)	
	Burner Off	- 3/8 (-16)	N/A

150 psi (10.5 kg/cm²) Levels

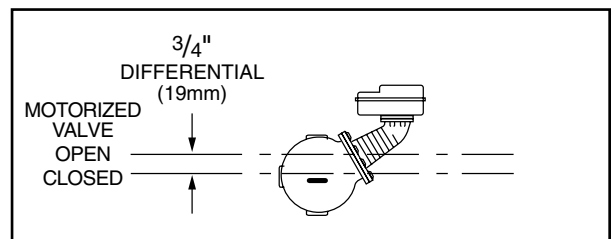
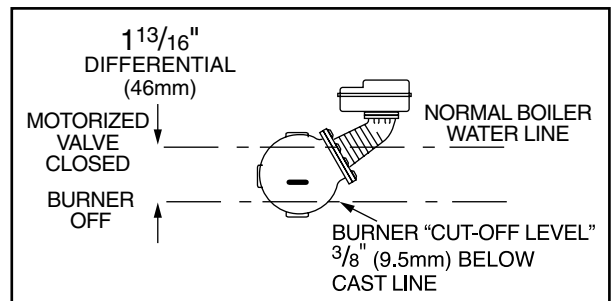

NOTE: Due to the slower operation of some motorized valves, complete valve opening or closing will occur at slightly different levels than indicated above.

Settings and Differential Pressures (continued)

Values are $\pm 1/8"$ (3.2mm).

Model 159S

Pressure	Setting	Approximate Distance Above Cast Line In. (mm)	Differential In. (mm)
0 psi (0 kg/cm ²)	Pump #1 Off	15/16 (24)	5/16 (8)
	Pump #1 On	5/8 (16)	
	Pump #2 Off	5/8 (16)	3/8 (16)
	Pump #2 On	1/4 (6.4)	
150 psi (10.5 kg/cm ²)	Pump #1 Off	1 3/8 (41)	3/4 (19)
	Pump #1 On	5/8 (16)	
	Pump #2 Off	7/8 (22)	7/8 (22)
	Pump #2 On	0 (0)	

150 psi (10.5 kg/cm²) Levels

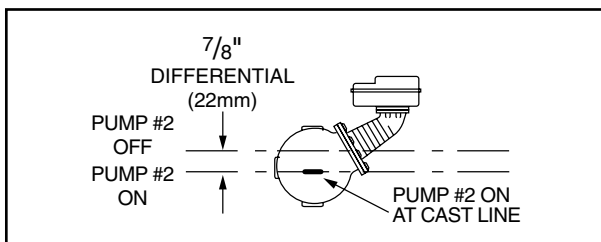
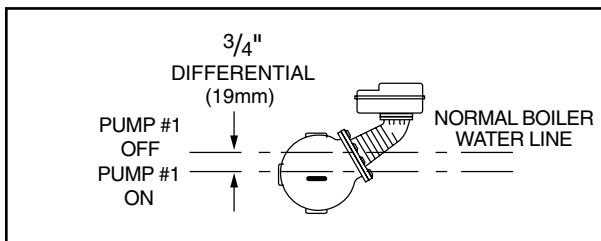
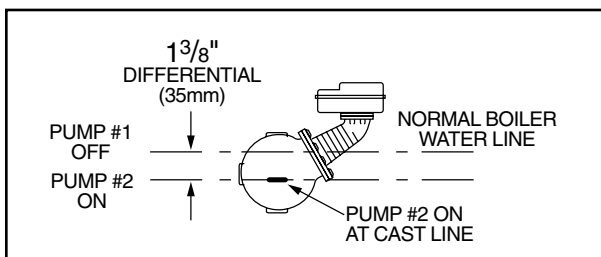

INSTALLATION

TOOLS NEEDED:

Two (2) pipe wrenches, one (1) flathead screw driver, and pipe sealing compound.

IMPORTANT: Follow the boiler manufacturer's instructions along with all applicable codes and ordinances for piping, blow down valve and water gauge glass requirements.

STEP 1 - Determine the Elevation at Which the Low Water Cut-Off/Pump Controller Must be Installed

If the control will be the **primary low water fuel cut-off**, size the steam (top) and water (bottom) equalizing pipe lengths so that the horizontal cast line on the body is **1 3/8" (35mm) below** the boiler's **normal water level**, but not lower than the **lowest, safe permissible water level**, as determined by the boiler manufacturer.

OR

If the control will be the **secondary low water fuel cut-off**, size the steam (top) and water (bottom) equalizing pipe lengths so that the horizontal cast line on the body is **at or above**, the **lowest, safe permissible water level**, as determined by the boiler manufacturer.

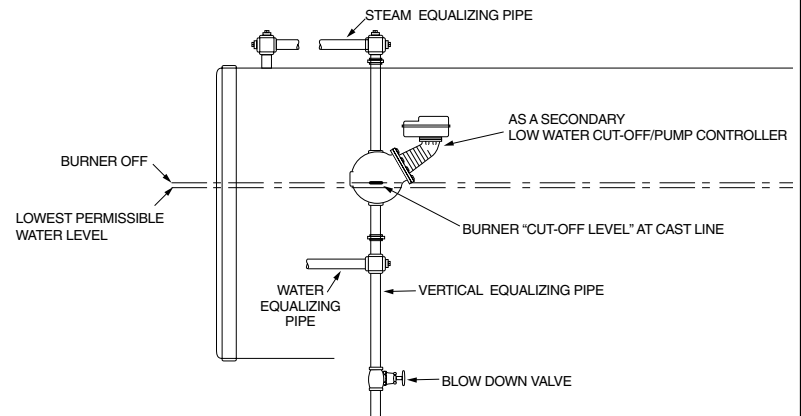
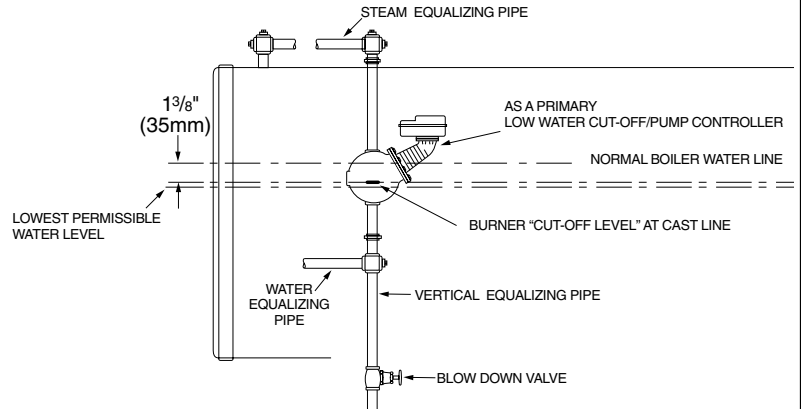

STEP 2 - Installing the Low Water Cut-Off

- a. Using a pipe wrench, unscrew the plastic float blocking plug (A) from the low water cut-off body (B).

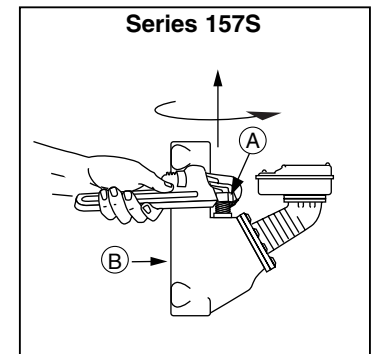
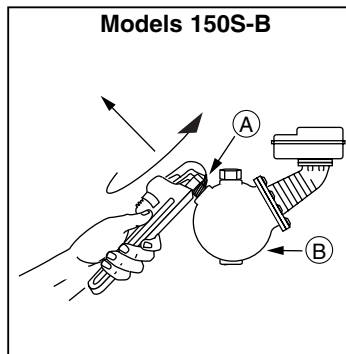
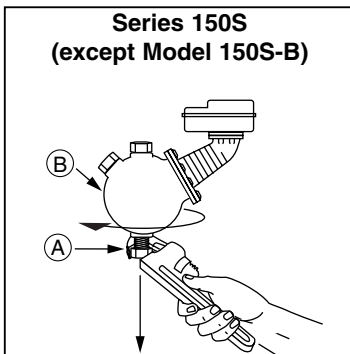

b. For Model 150S-B and Series 157S

(For all other models, proceed to Step 3).

Screw the 3/4" NPT steel plug (C) (provided) in tapping (A).

CAUTION

The plug must be reinstalled before control is shipped installed on the boiler, and removed when boiler is installed after shipment. Failure to follow this caution may damage float and operating mechanism.

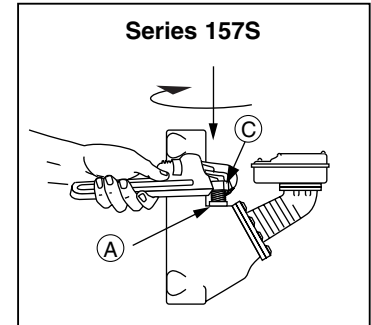
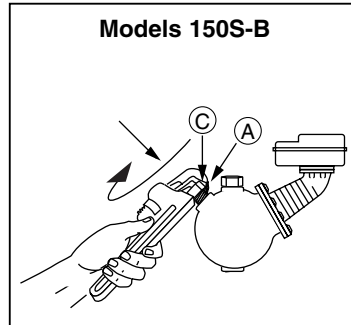

c. Mount and pipe the low water cut-off (D) on a vertical equalizing pipe (E) at the required elevation level, as determined in Step 1.

Install a full ported blow down valve (G) directly below the lower cross of the water equalizing pipe (F).

Note: 1" NPT tappings are provided, with the exception of some 157 and 157S models which are 1 1/4" NPT.

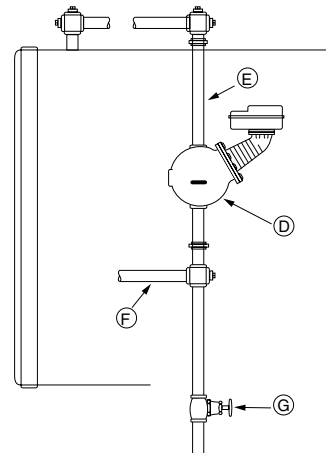

STEP 3 - Installing a Water Gauge Glass (Required on all steam boilers)

a. Install a water column (H) (not included with product) for all models except Series 157S (with integral water column).

b. Install a water gauge glass (J).
Note: Gauge glass and tri-cocks not included with product.

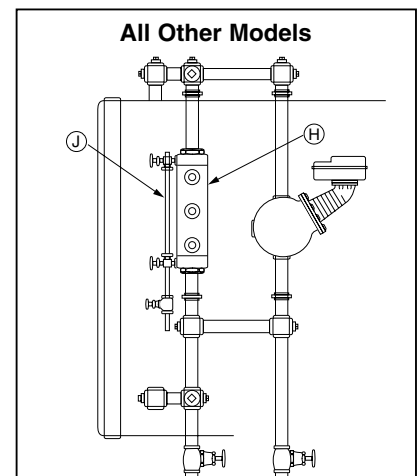
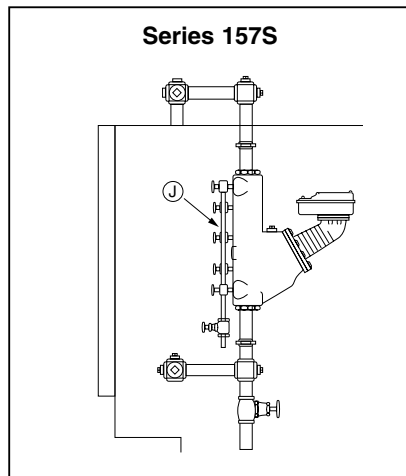

STEP 4 - Electrical Wiring

WARNING



- To prevent a fire, do not use this product to switch currents over 7.4A, 1/3 Hp at 120 VAC or 3.7A, 1/3 Hp at 240 VAC, unless a starter or relay is used in conjunction with it.
- To prevent electrical shock, turn off the electrical power before making electrical connections.
- This low water cut-off must be installed in series with all other limit and operating controls installed on the boiler. After installation, check for proper operation of all of the limit and operating controls, before leaving the site.



- Modification of the switch assembly before or after installation could cause damage to the boiler and/or boiler system.
- Failure to follow this warning could cause electrical shock, an explosion and/or a fire, which could result in property damage, personal injury or death.

Switch Operation

For all Models except 158S and 159S

Boiler feed pump off,
burner on, alarm off.

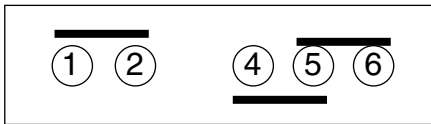

Boiler feed pump on,
burner on, alarm off.

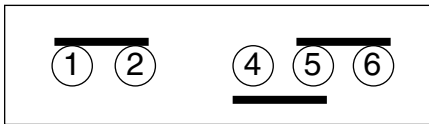

Boiler feed pump on,
burner off, alarm on.

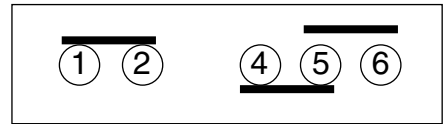

For Model 158S

Motorized valve closed,
burner on, alarm off.

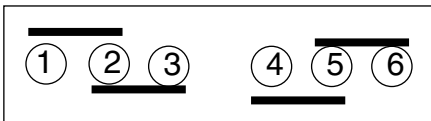

Motorized valve open,
burner on, alarm off.

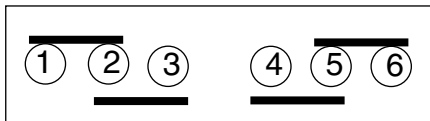

Motorized valve open,
burner off, alarm on.

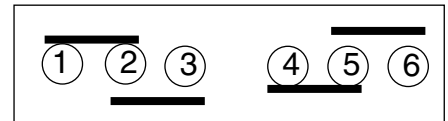

For Model 159S

Pump #1 off,
pump #2 off.

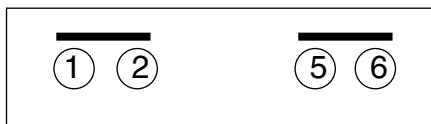

Pump #1 on,
pump #2 off.



Pump #1 on,
pump #2 on.



- Using a flathead screwdriver, remove the junction box cover (K).

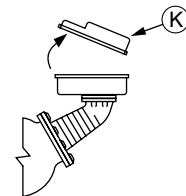

b. Following the appropriate wiring diagram, (refer to page 9) based on your application requirements, and using BX armored cable or Thinwall electrical metal tubing connector fittings, make electrical connections to the junction box (L).

IMPORTANT: There must be a minimum space of 1/2" (13mm) between connector fittings and electrical live metal parts.

Snap Switches (Series 150S and 157S)

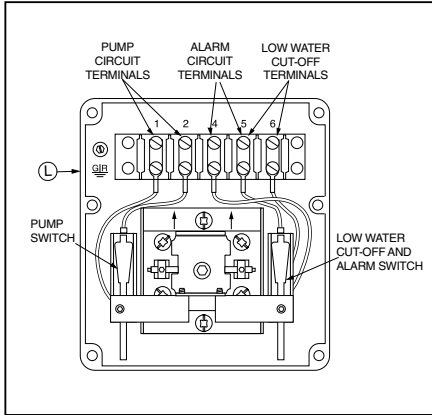

**Automatic Reset
(All models except 158S and 159S)**

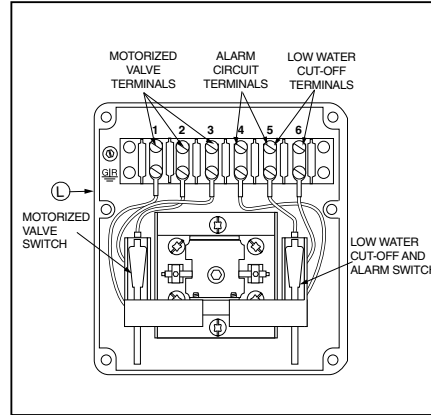

**Automatic Reset
Model 158S**

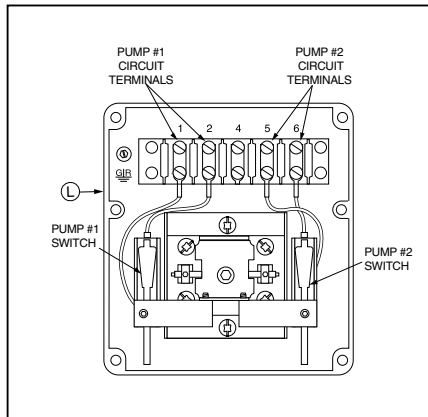

**Automatic Reset
Model 159S**

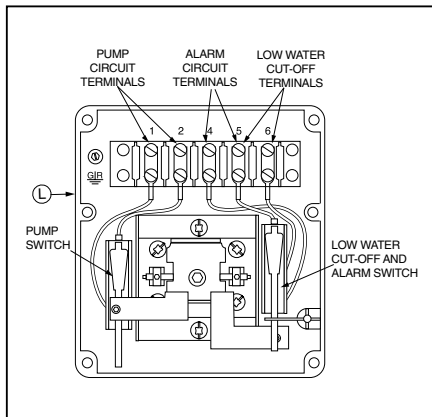

**Manual Reset
(All models except 158S)**

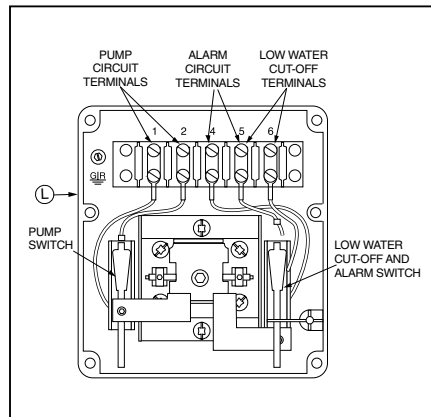

**Manual Reset
Model 158S-M**

WIRING DIAGRAMS

For Motorized Valves, refer to the valve manufacturer's wiring instructions.

Low Water Cut-Off Only

1. Main Line Switch - For burner circuits within the switch's electrical rating.
2. Pilot Switch - To holding coil of a starter when the burner circuit exceeds the switch's electrical rating.

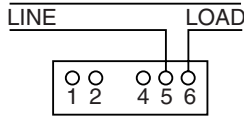

OR

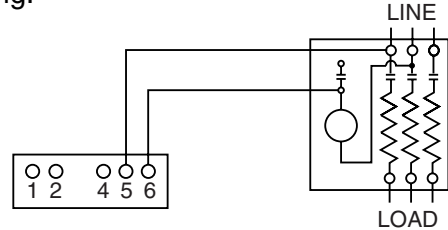

Pump Control Only

1. Install a starter or relay in pump control circuit, as shown, to prevent damage to snap switch and help insure proper switch/control operation. Failure to do so may shorten the life of the switch when actual amperage exceeds switch rating.

NOTE: For Model 159S, use terminals 5 and 6 from starter or relay for pump # 2.

2. Connect wires from holding coil of pump starter or relay to terminals 1 and 2 as shown.

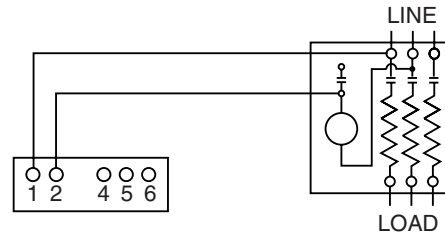

NOTE: To help insure most effective operation, balance boiler feed pump(s) to deliver required water feeder rate to match boiler steaming requirements.

Alarm Circuit Only

1. Low Water Alarm

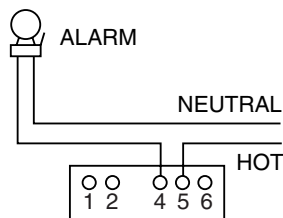

2. High Water Alarm

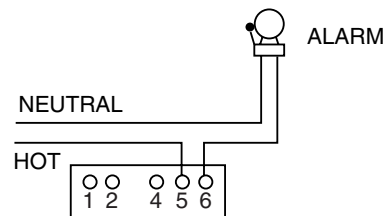

OR

Combination Pump Control, Low Water Cut-Off and Alarm

1. Main Line Switch - For burner circuits within the switch's electrical rating.
2. Pilot Switch - To holding coil of a starter when the burner circuit exceeds the switch's electrical rating.

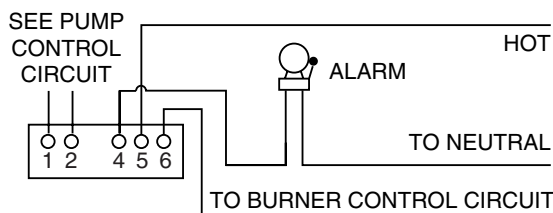

OR

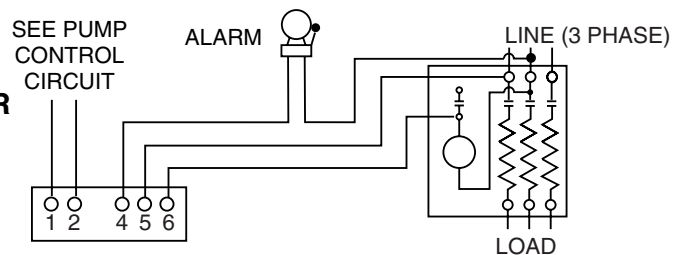

6. Re-attach the junction box cover (K).

Note:
Cover must be installed correctly as shown

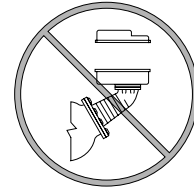
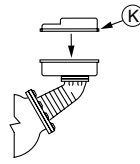

STEP 5 - Testing

This control is factory calibrated for specific applications. The following testing procedure is only meant to serve as a verification of proper operating sequence. Dimensions provided are typical for a boiler not being fired and/or not at pressure. Actual operating ranges are shown on page 2 in the "Operation" section.

IMPORTANT: Follow the boiler manufacturer's start-up and operating instructions along with all applicable codes and ordinances. **Note:** Water levels stated below are only for 150 psi (10.5 kg/cm²) operation.

- a. Turn on the electric power to the boiler. With the boiler empty the pump should go on and the burner must remain off.

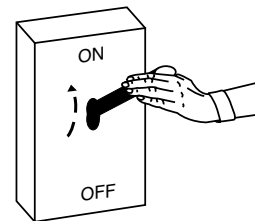

WARNING



If the burner comes on, immediately turn the boiler off and make the necessary corrections.

Failure to follow this warning could cause an explosion or fire and result in property damage, personal injury or death.

- b. The boiler should begin to fill with water. Watch the gauge glass (J) until the water level reaches approximately $\frac{7}{8}$ " (22mm) above the horizontal cast line (M) on the low water cut-off.

IMPORTANT: If water does not start filling the boiler, immediately turn off the the boiler and make the necessary corrections.

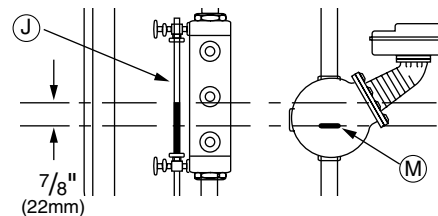

c. **For automatic reset models only.** When the water level reaches approximately $\frac{7}{8}$ " (22mm) above the horizontal cast line (lower for MD models) the burner should come on (pump #2 should shut off with Model 159S).

OR

For manual reset models only. When the water level reaches approximately $\frac{7}{8}$ " (22mm) above the horizontal cast line press the reset button (N). The burner should then come on.

Snap Switch Models

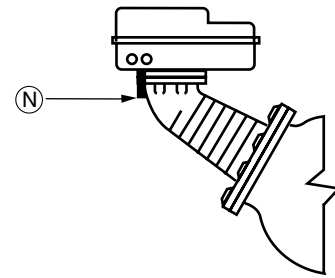

d. Continue watching the gauge glass (J) to see that the water continues to rise to approximately $1\frac{3}{8}$ " (35mm) ($1\frac{7}{16}$ " (37mm) for MD models) above the horizontal cast line (M). The pump should shut off (the motorized valve should close with Models 158 and 158S, or with Models 159 and 159S, pump #1 should shut off).

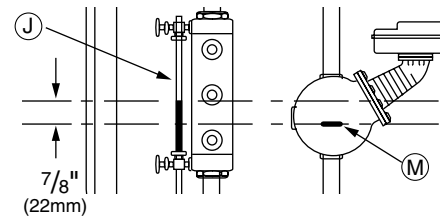

CAUTION



To prevent serious personal injury from steam pipe blow down, connect a pipe to avoid exposure to steam discharge.

Failure to follow this caution could cause personal injury.

e. Blow down the control when the water in the boiler is at its normal level and the burner is on. Follow Blow Down Procedure found in Maintenance Section on the last page of these instructions.

INSTALLATION COMPLETE

MAINTENANCE

SCHEDULE:

Blow down control as follows when boiler is in operation.

- Daily if operating pressure is above 15 psi.
- Weekly if operating pressure is below 15 psi.

NOTE

More frequent blow-down may be necessary due to dirty boiler water and/or local codes.

- **Remove head assembly and inspect water side components annually.** Replace head assembly if any of the internal components are worn, corroded or damaged or if control no longer operates properly.
- **Inspect the float chamber and equalizing piping annually.** Remove all sediment and debris.

NOTE

The control may need to be inspected and cleaned more frequently on systems where there is the potential of excessive scale or sludge build-up. This includes systems:

- With high raw water make-up
- With no condensate return
- With untreated boiler water
- Where significant changes have been made to the boiler-water chemical treatment process
- With oil in the boiler water

Replace head mechanism every 5 years.

More frequent replacement may be required when severe conditions exist.

Replacement parts are available from your local authorized McDonnell & Miller Distributor.

The use of parts or components other than those manufactured by McDonnell & Miller will void all warranties and may affect the units compliance with listings or regulating agencies.

BLOW DOWN PROCEDURE:

CAUTION



To prevent serious personal injury from steam pipe blow down, connect a drain pipe to the control opening to avoid exposure to steam discharge.

Failure to follow this caution could cause personal injury.

When blowing down a control at pressure, the blow down valves should be opened slowly. The piping needs to be warmed up and stagnant water in the drain piping needs to be pushed out. Suddenly opening a blow down valve causes steam to condense, which can create water hammer.

Damage to components can occur when water hammer occurs due to improper blow down piping. For these reasons, McDonnell & Miller recommends a dual valve blow-down system for each control.

Blow down the control when the water in the boiler is at its normal level and the burner is on.

NOTE: Refer to page 2 for switch operating points.

- Open upper valve (#1)
- Slowly open the lower valve (#2)
- Water in the sight glass should lower.
- As the water in the sight glass lowers, the pump should turn on.
- As the water continues to lower in the sight glass, the burner should turn off.
- Slowly close the lower valve (#2).
- Close the upper valve (#1)
- The water level in the sight glass should rise, first turning on the burner and then turning off the pump.

NOTE: On manual reset models, the reset button will need to be pressed after the water level has been restored before the burner will operate.

NOTE

If this sequence of operation does not occur as described, immediately close all the valves, turn off the boiler and correct the problem. Inspection/cleaning of the float mechanism may be required to determine why the control was not working properly. Retest the control after the problem has been identified and corrected.

