

Combination Low Water Cut-Off/Pump Controllers For Steam Boilers

Series 93 & 193

Low Water Cut-Off/Pump Controllers

Replacement Head Mechanisms

For Model	Repl. Head Model No.	Description	Weight lbs. (kg)
93, 193	93-HD	Head mechanism	16 (7.25)
	93-7B-HD	Head mechanism with 7B switch	16 (7.25)
	93-M-HD	Head mechanism, manual reset	16 (7.25)
	93-7B-M-HD	Head mechanism with 7B switch, manual reset	16 (7.25)

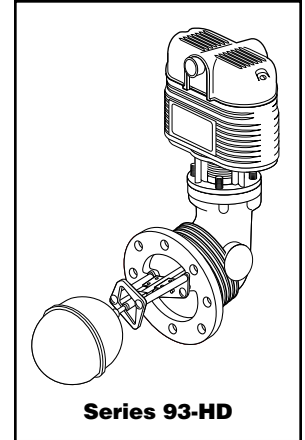

Components (shown on page 25)

Item Number	Part Number	Model Number	Description	Weight lbs. (kg)
1	162402	93-HDLS	Head w/o switch	15.0 (6.8)
2	345700	SA91-60	Float (includes item 3)	0.7 (.32)
3	325400	150-14	Gasket	0.1 (.05)
4	110300	5	Electric switch	3.5 (1.6)
5	110400	5-M	No. 5 w/manual reset	3.5 (1.6)
6	110800	7B	Electric switch/ proportioning control	4.0 (1.8)
7	110900	7B-M	No. 7B w/manual reset	4.0 (1.8)



#5 Switch

1	344800	SA91-30B	Burner Switch Contact Assembly (Red dot on terminal panel) (Includes 1A terminal panel)	0.1 (.05)
2	345000	SA91-30P	Pump Switch Contact Assembly (Blue dot on terminal panel) (Includes 2A terminal panel)	0.1 (.05)



#7B Switch

1	344800	SA91-30B	Burner Switch Contact Assembly (Red dot on terminal panel) (Includes 1A terminal panel)	0.1 (.05)
2	309000	7B-1R	Resistor/Slide Wire Assembly	0.1 (.05)
3	345150	SA7-30	Terminal Panel	0.5 (.23)

Combination Low Water Cut-Off/ – Pump Controllers For Steam Boilers

Series 93 & 193 (continued)

Low Water Cut-Off/Pump Controllers

Components

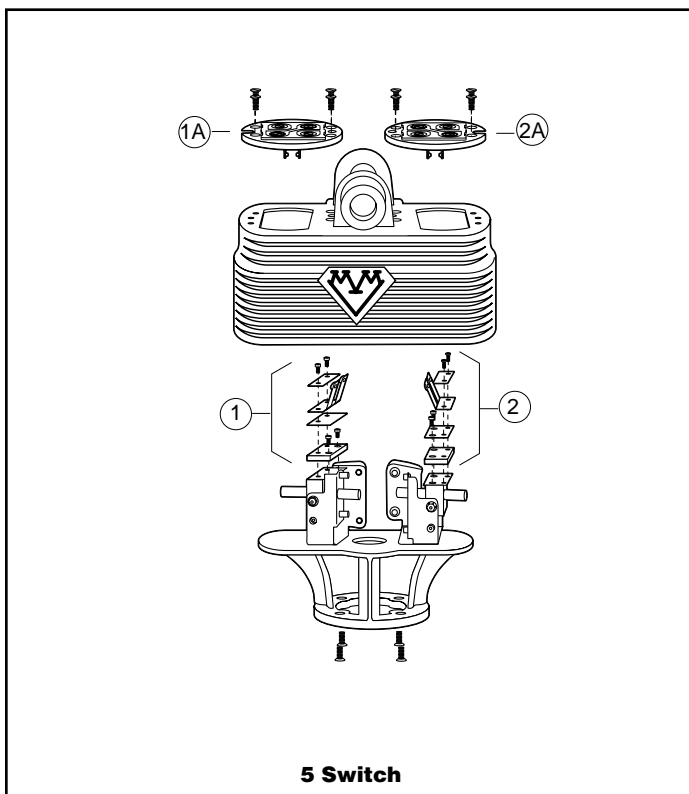
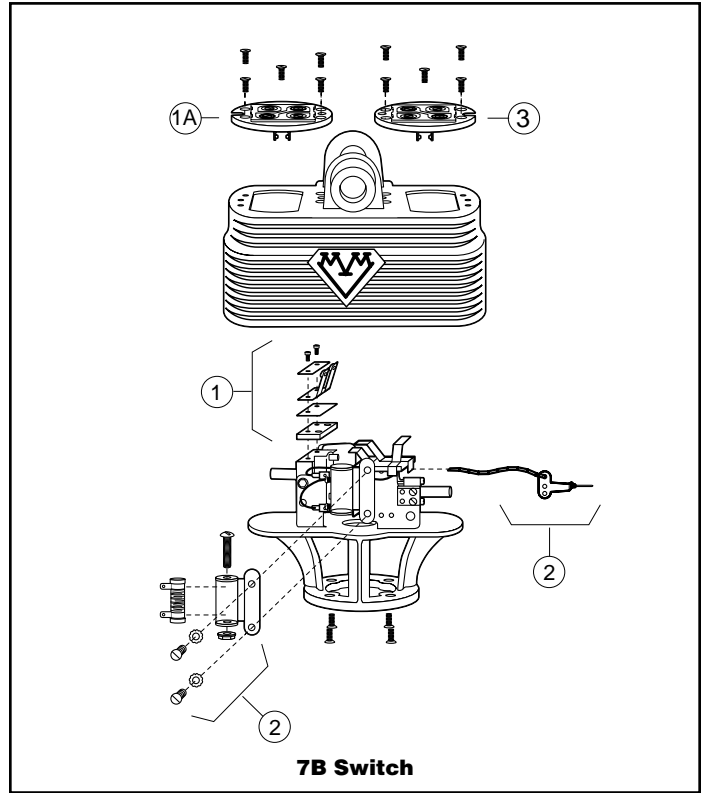
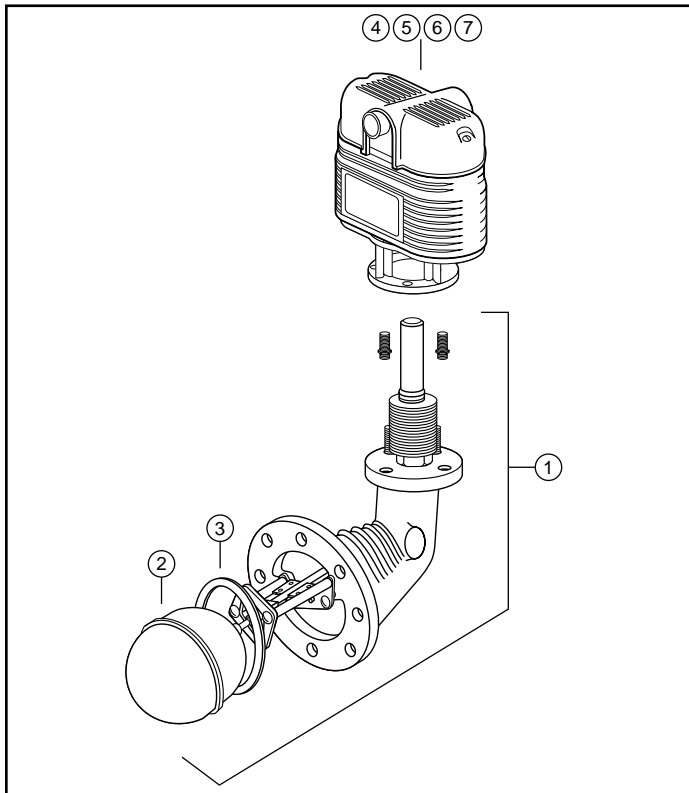

BOILER CONTROLS