



**McDonnell & Miller**  
 Installation & Maintenance  
 Instructions  
 MM-307(F)

**Series 101-A**  
**Electric Water Feeder**



**Applications:**

For use on low pressure boilers with cold water feed. The Series 101-A can be used with mechanical or electronic low water cut-off controls.

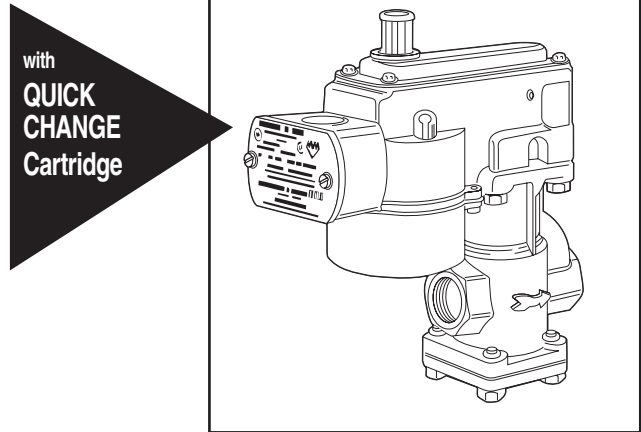

<b>⚠ WARNING</b>
Do not use automatic water feeders with manual reset LWCO's. Failure to follow this warning could cause flooding, property damage, personal injury or death.

**SPECIFICATIONS**

**Maximum Water Pressure:** 150 psi (10.5 kg/cm<sup>2</sup>)  
**Maximum Boiler Pressure:** 25 psi (1.76 kg/cm<sup>2</sup>)  
**Maximum Boiler Size:** 5000 sq. ft. EDR  
 2,350,000 BTU/HR  
 Output Capacity  
**Maximum Water Temperature:** 120°F (49°C)

**Electrical Ratings**

Model	Voltage	Full Load
101A-120	120V	40 VA
101A-24	24V	40 VA

**NOTE:** 101A-24 includes a transformer with 120 volt primary and 24 volt/50VA secondary.

**Flow Data**

Pressure Differential psi (kg/cm <sup>2</sup> )		Flow Rate gpm (lpm)	
5	(.4)	1.4	(5.3)
10	(.7)	1.7	(6.4)
20	(1.4)	2.1	(7.9)
40	(2.8)	2.9	(11.0)
60	(4.2)	3.4	(12.9)
80	(5.6)	4.0	(15.1)

<b>⚠ WARNING</b>	
	• Before using this product read and understand instructions.
	• Save these instructions for future reference.
	• All work must be performed by qualified personnel trained in the proper application, installation, and maintenance of plumbing, steam, and electrical equipment and/or systems in accordance with all applicable codes and ordinances.
	• Boiler manufacturer schematics should always be followed. In the event that the boiler manufacturer's schematic does not exist, or is not available from the boiler manufacturer, refer to the schematics provided in this document.
	• To prevent water damage check to make sure there is adequate floor drainage capacity. Check all components in the system to insure that they will not leak in the event of an overfeed condition.
	• To prevent electrical shock, turn off the electrical power before making electrical connections.
Failure to follow this warning could cause property damage, personal injury or death.	

# INSTALLATION

## STEP 1 - Determine Where to Install the Water Feeder

### IMPORTANT

Boiler manufacturer schematics should always be followed. In the event that the boiler manufacturer's schematic does not exist, or is not available from the boiler manufacturer, refer to the schematics provided in this document.

#### Determine where to install the water feeder based on the following requirements:

- a. It must be installed within eyesight of the boiler.
- b. A minimum 6" (152mm) clearance should be allowed on all sides for servicing.
- c. It must be installed in a horizontal pipe in the upright position.
- d. It should be installed on the cold water line.

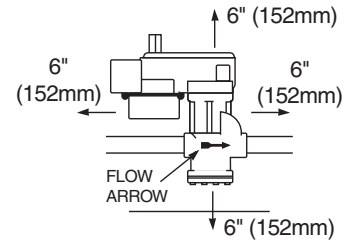

#### Installation Diagram and Requirements

- a. Piping must be 1/2" (15mm) NPT minimum.
- b. Full port/full flow valves rated for the pressure/temperature of the system and piping they are to be installed on.
- c. Arrow on feeder casting must point in direction of flow into the boiler.
- d. Install isolation valves and unions on the inlet and outlet piping of the feeder for easier trouble-shooting and repair/replacement.
- e. Install manual fill valve and bypass line to allow for removal of the valve while the boiler is in service.

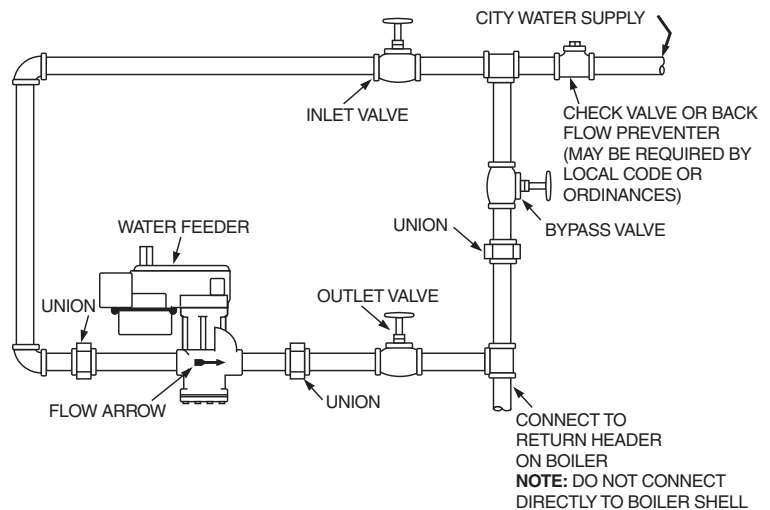

## STEP 2 - Electrical Installation

### IMPORTANT

Boiler manufacturer schematics should always be followed. In the event that the boiler manufacturer's schematic does not exist, or is not available from the boiler manufacturer, refer to the schematics provided in this document.

#### NOTE

Before connecting water feeder, operate boiler and check all safety devices.

#### NOTE

Unless otherwise noted, water feeder voltage should be the same as the LWCO and burner circuit voltage.

## ⚠ WARNING



• All work must be performed by qualified personnel trained in the proper application, installation, and maintenance of plumbing, steam, and electrical equipment and/or systems in accordance with all applicable codes and ordinances.



• To prevent electrical shock, turn off the electrical power before making electrical connections.

• To prevent an electrical fire or equipment damage, electrical wiring insulation must have a rating of 167°F (75°C) if the liquid's temperature exceeds 180°F (82°C).



• To prevent an electrical fire or equipment damage, water feeder wiring must be on same circuit as all other boiler controls.

Failure to follow this warning could cause property damage, personal injury or death.

a. Test the Low Water Cut-Off on the boiler.

b. Mark location of water level on sight glass where Low Water Cut-Off turns off burner. This will be used as reference to test the water feeder's operation.

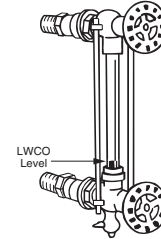

c. Turn off all power to boiler and boiler controls.

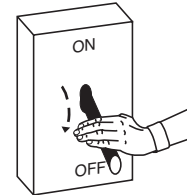

d. Using a flathead screwdriver, remove electrical cover plate.

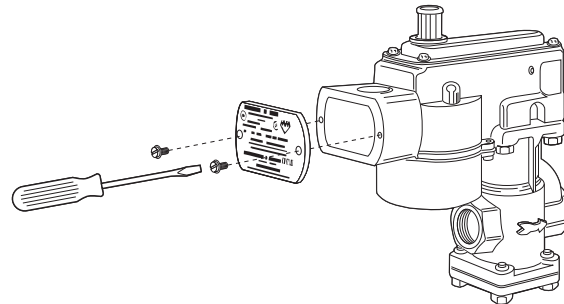

f. Connect electric conduit to the water feeder's electrical enclosure.

g. Based on the water feeder and low water cut-off combination you are installing, select proper wiring diagram and proceed to that page.

<b>Water Feeder Model</b>	<b>&amp;</b>	<b>Low Water Cut-Off Model</b>	<b>Page</b>
101A-120	&	67 with 24V or 120V burner circuit .....	4
101A-24	&	67 with 24V or 120V burner circuit .....	4-5
101A-120	&	67G with millivolt burner circuit .....	5
101A-24	&	67G with millivolt burner circuit .....	5
101A-24	&	PS-802-24 .....	6
101A-120	&	PS-801-120 .....	6

## Wiring Diagram Legends

1. Bold lines indicate action to be taken in Step shown. —
2. Regular black lines indicate existing wiring. —

### For McDonnell & Miller Model 101A-120 Water Feeder and Series 67 Low Water Cut-Off with 120 volt burner circuit

- h. Connect wire (A) from water feeder to burner circuit Neutral wire.
- i. Install jumper between terminals 2 and 3 of the low water cut-off.
- j. Install wire (B) from water feeder to terminal 4 of the low water cut-off.

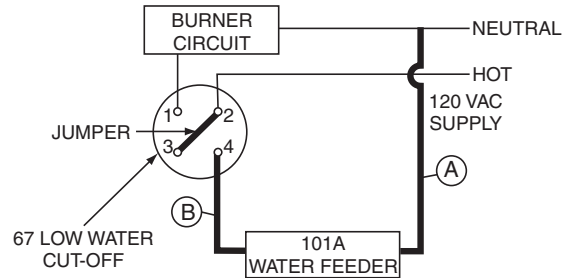

### For McDonnell & Miller Model 101A-120 Feeder and Series 67 Low Water Cut-Off with 24 volt burner circuit

- h. Install wire (A) from water feeder to 120 volt Neutral wire.
- i. Install wire (B) from water feeder to terminal 4 of the low water cut-off.
- j. Install wire (C) from terminal 3 of the low water cut-off to 120 volt Hot wire.

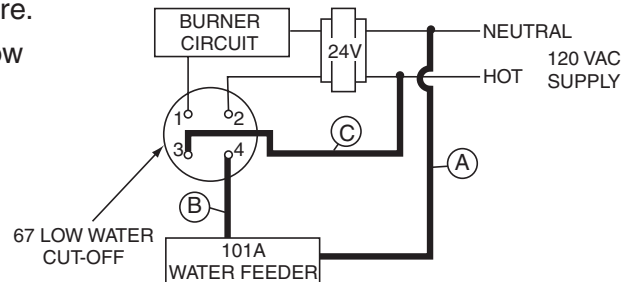

### For Model 101A-24 Water Feeder and Series 67 Low Water Cut-Off with 24 volt burner circuit

- h. Install wire (A) from burner circuit Neutral wire to the transformer input Neutral terminal.
- i. Install wire (B) from burner circuit Hot wire to the transformer input Hot terminal.
- j. Install wire (C) from transformer output Neutral terminal to the water feeder.
- k. Install wire (D) from the water feeder to terminal 4 on the low water cut-off.
- l. Install wire (E) from terminal 3 on the low water cut-off to the transformer output Hot terminal.

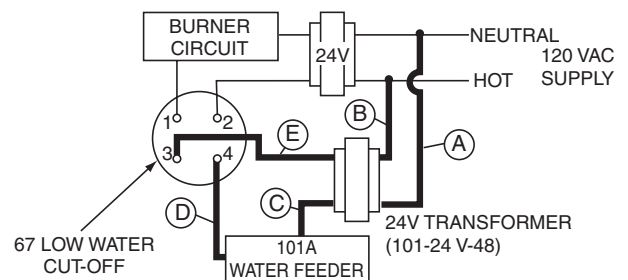

## **IMPORTANT**

To prevent damage to the water feeder, a McDonnell & Miller transformer Model 101-24V-48 must be used.

**For Model 101A-24 Water Feeder and Series 67 Low Water Cut-Off with 120 volt burner circuit**

- h. Install wire (A) from burner circuit Neutral wire to the transformer input Neutral terminal.
- i. Install wire (B) from burner circuit Hot wire to the transformer input Hot terminal.
- j. Install wire (C) from transformer output Neutral terminal to the water feeder.
- k. Install wire (D) from the water feeder to terminal 4 on the low water cut-off.
- l. Install wire (E) from terminal 3 on the low water cut-off to the transformer output Hot terminal.

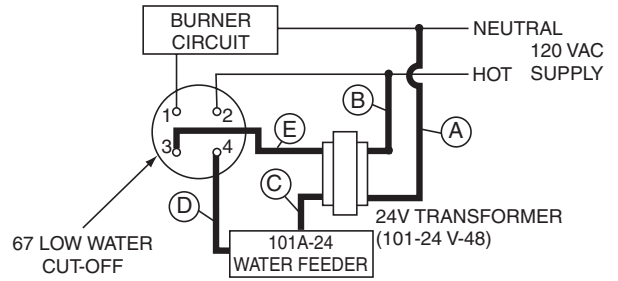

**⚠ IMPORTANT**

To prevent damage to the water feeder, a McDonnell & Miller transformer Model 101-24V-48 must be used.

**For Model 101A-120 Feeder and Model 67G with millivolt burner circuit**

- h. Install wire (A) from water feeder to 120 volt Neutral wire.
- i. Install wire (B) from water feeder to terminal 4 of the low water cut-off.
- j. Install wire (C) from terminal 3 of the low water cut-off to 120 volt Hot wire.

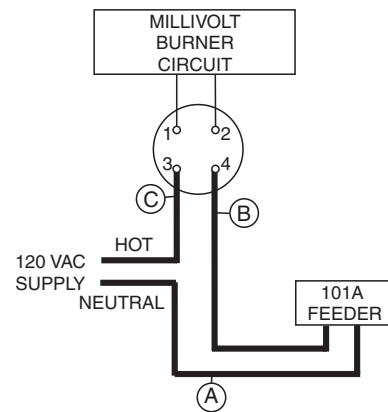

**For Model 101A-24 Feeder and Model 67G with millivolt burner circuit**

- h. Install wire (A) from 120 volt circuit Neutral wire to the transformer input Neutral terminal.
- i. Install wire (B) from 120 volt circuit Hot wire to the transformer input Hot terminal.
- j. Install wire (C) from transformer output Neutral terminal to the water feeder.
- k. Install wire (D) from the water feeder to terminal 4 on the low water cut-off.
- l. Install wire (E) from terminal 3 on the low water cut-off to the transformer output Hot terminal.

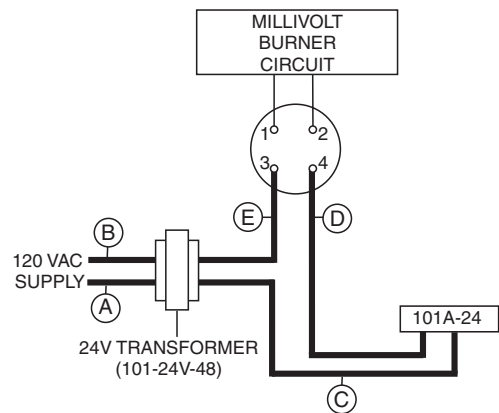

**⚠ IMPORTANT**

To prevent damage to the water feeder, a McDonnell & Miller transformer Model 101-24V-48 must be used.

## For Model 101A-24 Water Feeder and Model PS-802-24 Low Water Cut-Off

Replace existing 24 volt transformer on boiler with the McDonnell and Miller transformer Model 101-24 V-48 included with the Model 101A-24 water feeder.

- h. Install wire (A) from the water feeder to terminal N on the low water cut-off.
- i. Install wire (B) from the water feeder to terminal W on the low water cut-off.
- j. Install jumper bar or wire from terminal H to terminal C on the low water cut-off.

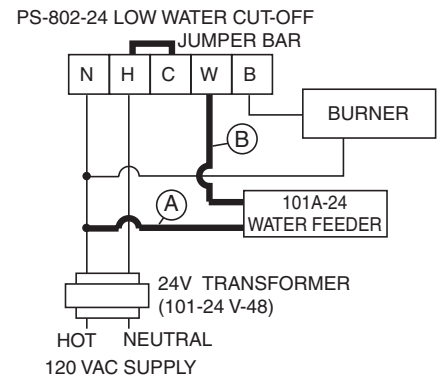

### **IMPORTANT**

To prevent damage to the water feeder, a McDonnell & Miller transformer Model 101-24V-48 must be used.

## For Model 101A-120 Water Feeder and Model PS-801-120 Low Water Cut-Off

- h. Install wire (A) from the water feeder to terminal 2 on the low water cut-off.
- i. Install wire (B) from the water feeder to terminal 4 on the low water cut-off.

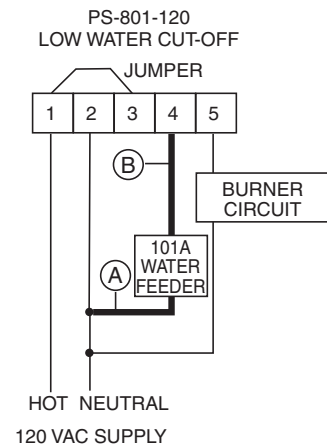

Reinstall electrical cover plate.

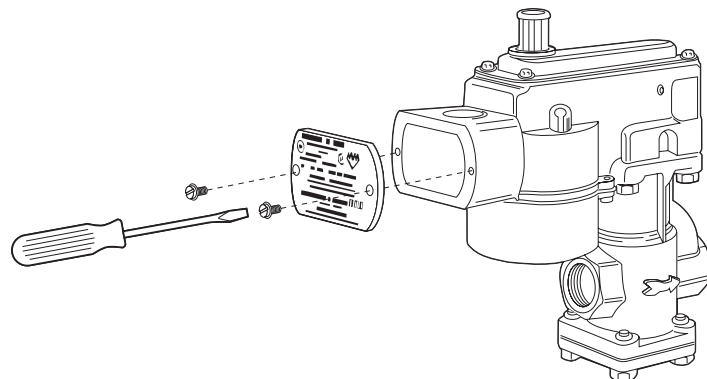

---

# TESTING

**NOTE:** The water feeder will only restore the boiler water level to approximately 1/2" to 1" (13-25mm) above the burner cut-off level of the low water cut-off.

## Burner Off (Cold) Test

1. Manually fill boiler until water level in the sight glass is more than half filled.
2. With the room thermostat set at the lowest setting, turn on the power to the boiler and water feeder.
3. Using the sight glass as a reference, slowly drain water from boiler by opening the low water cut-off blow down valve or the boiler drain until the low water cut-off activates the water feeder.

**IMPORTANT:** If the water feeder does not activate before the water level reaches the bottom of the sight glass, immediately close any open drain or blow down valve and check controls and piping for proper installation. Correct any problems.

4. Using the sight glass as a reference, see that the water feeder activates and fills to approximately 1/2" to 1" (13 - 15mm) above the burner cut-off level of the low water cut-off.

**IMPORTANT:** If the water feeder does not turn off once the water level has surpassed the halfway point of the sight glass, immediately turn off the power to the boiler and water feeder and check control for proper installation. Correct any problems.

5. Repeat test 2 or 3 times. Restore boiler and controls to normal settings.

## Burner On (Hot) Test

1. Manually fill the boiler to the boiler manufacturer's recommended operating level.
2. Turn on the power to the boiler and water feeder. Activate the burner by raising the thermostat set point.
3. As steam is generated, the boiler water level will decrease. Slowly open the low water cut-off blow down valve or the boiler drain to lower the water level to the proper level, necessary to activate water feeder.

**IMPORTANT:** If the water feeder does not activate before the water level reaches the bottom of the sight glass, immediately turn off power to the boiler and close any open drain or blow down valve and check controls and piping for proper installation. Correct any problems.

4. Using the sight glass as a reference, see that the water feeder activates and fills to approximately 1/2" to 1" (13 - 15mm) above the burner cut-off level of the low water cut-off.

**IMPORTANT:** If the water feeder does not turn off once the water level has surpassed the halfway point of the sight glass, immediately turn off the power to the boiler and water feeder and check control for proper installation. Correct any problems.

5. Repeat test 2 or 3 times. Restore boiler and controls to normal settings.

---

## INSTALLATION COMPLETE

## TROUBLESHOOTING

Problem:

### 1. Pipes rattle when valve is operating.

**Solution:**

- a. Secure all piping.
- b. Install an air chamber on water feeder inlet pipe.

### 2. Water feeder doesn't activate.

**Solution:**

- a. Check wiring and connections to make sure they are correct and secure.
- b. Make sure that the low water cut-off is operating properly.

### 3. Water feeder activates, but does not feed water to the boiler.

**Solution:**

- a. Make sure all valves are open.
- b. Remove and clean strainer.
- c. Remove and clean cartridge valve assembly.
- d. Make sure the water feeder is properly piped to the boiler.
- e. Make sure the piping is not restricted or clogged.

### 4. Water feeder does not shut off.

**Solution:**

- a. Check wiring and connections to make sure they are correct and secure.
- b. Make sure that the low water cut-off is operating properly.
- c. Make sure manual feed button operates freely.

## MAINTENANCE

### SCHEDULE:

#### Annually

- **Disassemble and inspect/clean strainer screen.**  
Replace if screen is torn or not able to be cleaned.
- **Remove and inspect/clean cartridge.** Replace if poppet does not move freely or debris cannot be removed.
- **Check all wires for brittle or worn insulation.**  
**More frequent cleaning or replacement may be required if used in locations where water treatment is required or in applications with high make-up water requirements.**

### NOTE

Use clean water to rinse components and surfaces. DO NOT use sharp objects to scrape off any accumulations of sediment or debris.

**Replace entire unit including equalizing piping every 10 years.**

**Replace control if it has been subjected to water from a broken pipe or flooding.**

### Removal of cartridge and strainer for inspection and cleaning

- Using a 1/2" socket wrench, unscrew the four (4) hex-head bolts (B) that secure the strainer basket (H) to the valve assembly (E).
- Using a 13/16" socket wrench, unscrew the cartridge (D) and remove.
- Clean any debris (scale, rust, etc.) from strainer and cartridge. Poppet inside cartridge must move freely. Replace if debris cannot be removed or poppet does not move freely.
- Lubricate cartridge o-rings using silicone type lubricant and re-install.
- While depressing the manual feed (red) button, re-install the cartridge and tighten 2 ft. lbs. (2.6 N•m). Do not over-tighten.
- Re-install strainer basket. Tighten (4) bolts 8 ft. lbs. (11 N•m).

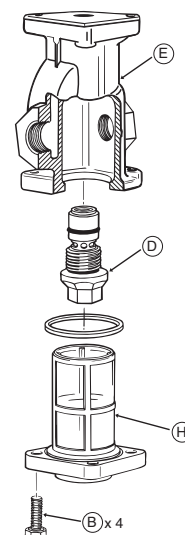

### Broken Union Test

Make sure that the water level in the boiler is above the closing level of the feeder.

Close valve 'X' and slowly open union 'Z' to determine if valve is leaking.

- If water is leaking from the union, the valve needs to be serviced.
- If no water leaks from the union, the feeder operation is not the cause of the flooding.

