



McDonnell & Miller

Installation & Maintenance
Instructions
MM-316(C)

Series 47 and 247 Mechanical Water Feeders

Series 47-2 and 247-2 Combination Mechanical Water Feeder/Low Water Cut-Off

Applications:

For steam and hot water boilers with cold water feed, to maintain a minimum safe water level independent of electrical service.

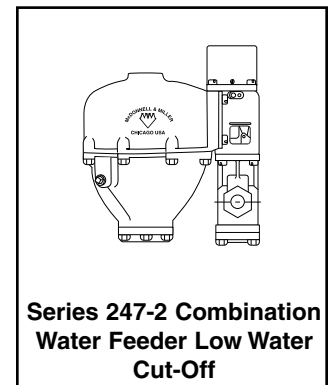
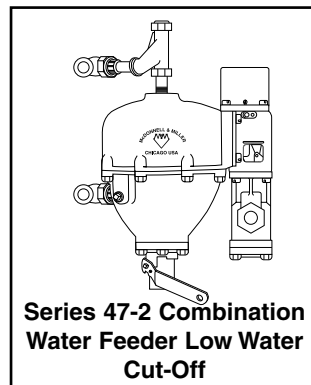
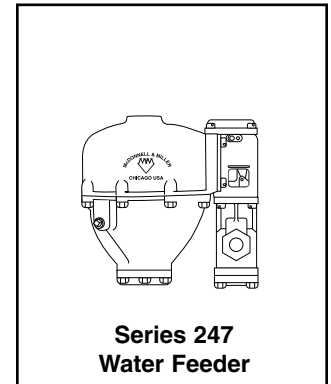
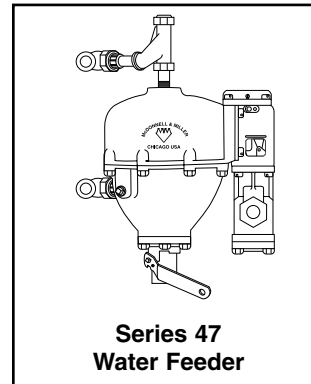

WARNING

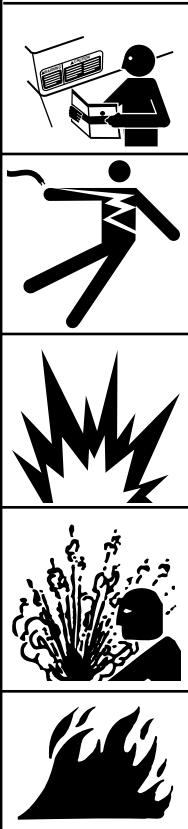

- Before using this product read and understand instructions.
 - Save these instructions for future reference.
 - All work must be performed by qualified personnel trained in the proper application, installation, and maintenance of plumbing, steam, and electrical equipment and/or systems in accordance with all applicable codes and ordinances.
 - To prevent serious burns, the boiler must be cooled to 80°F (27°C) and the pressure must be 0 psi (0 bar) before servicing.
 - To prevent electrical shock, turn off the electrical power before making electrical connections.
 - The low water cut-off switch must be installed in series with all other limit and operating controls installed on the boiler. After installation, check for proper operation of all of the limit and operating controls, before leaving the site.
 - We recommend that secondary (redundant) Low Water Cut-Off controls be installed on all steam boilers with heat input greater than 400,000 BTU/hour or operating above 15 psi steam pressure. At least two controls should be connected in series with the burner control circuit to provide safety redundancy protection should the boiler experience a low-water condition. Moreover, at each annual outage, the low water cutoffs should be dismantled, inspected, cleaned, and checked for proper calibration and performance.
 - Boiler manufacturer schematics should always be followed. In the event that the boiler manufacturer's schematic does not exist, or is not available from the boiler manufacturer, refer to the schematics provided in this document.
 - To prevent a fire, do not use this low water cut-off to switch currents over 10.2A, 1/2 HP at 120 VAC or 5.1A, 1/2 HP at 240 VAC, unless a starter or relay is used in conjunction with it.
- Failure to follow this warning could cause property damage, personal injury or death.

OPERATION

All Models

- **Maximum Water Pressure:** 150 psi (10.5 kg/cm²)
- **Maximum Water Temp:** 120°F (49°C)
- **Water Connection Size:** 1/2" NPT

47/47-2

- **Maximum Boiler Pressure:** 25 psi (1.76 kg/cm²)

247/247-2

- **Maximum Boiler Pressure:** 30 psi (2.1 kg/cm²)

Electrical Ratings

Motor Switch Rating (Amperes)			
Voltage	Full Load	Locked Rotor	Pilot Duty
120 VAC	10.2	61.2	125 VA at 120
240 VAC	5.1	30.6	or 240 VAC, 60 Hz

Series 47/47-2 Operating Levels

Series 47 Water Feeders and Series 47-2 Combination Water Feeder/Low Water Cut-Off maintain minimum water level in the boiler during normal operation.

Series 47-2 Combination Water Feeder/Low Water Cut-Off shuts off the burner if the boiler water level drops 1 3/16" (30mm) below the water feeder's closing level.

Series 47-2 Combination Water Feeder/Low Water Cut-Off allows the burner to operate on demand as the water level is restored to its proper level.

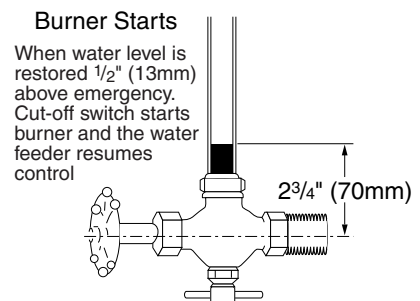
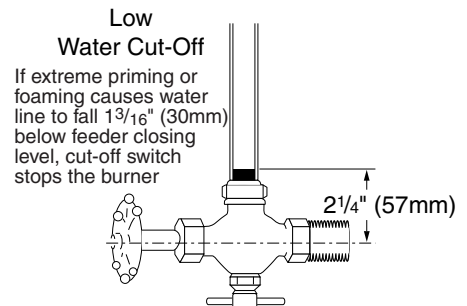
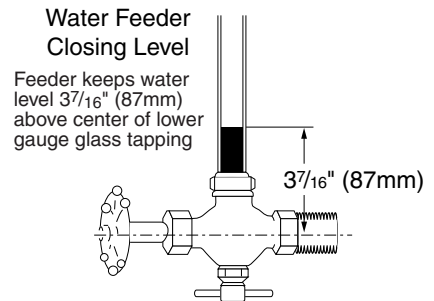

Series 247 and 247-2 Operating Level

Water feeder figures are +/- 1/4" (6.4mm)

Burner figures are +/- 1/8" (3.2mm)

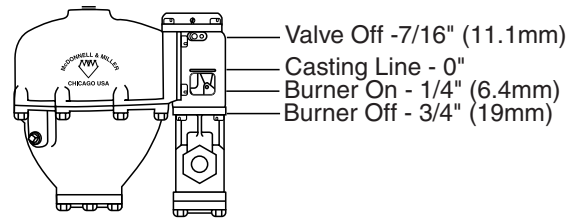

INSTALLATION –

TOOLS NEEDED:

Two (2) pipe wrenches, and one (1) flathead screwdriver.

STEP 1 - Determine Best Position to Install the Water Feeder

(to clear obstructions that may be encountered on the side of the boiler).

TOP VIEWS

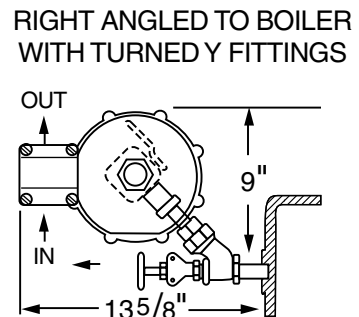
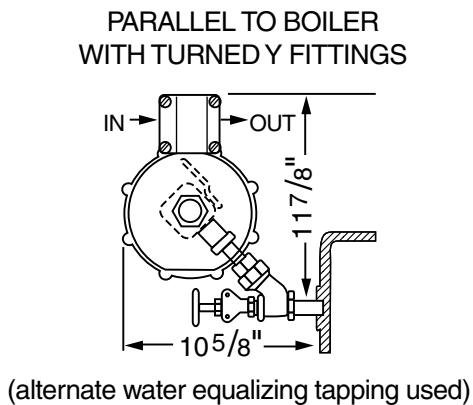
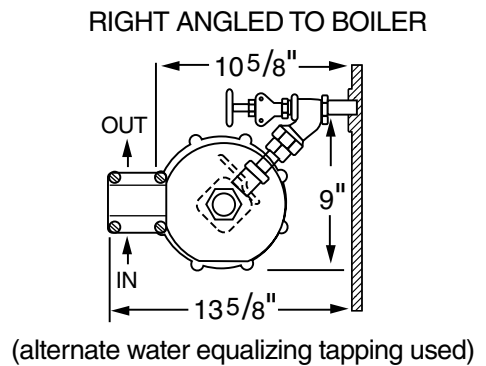
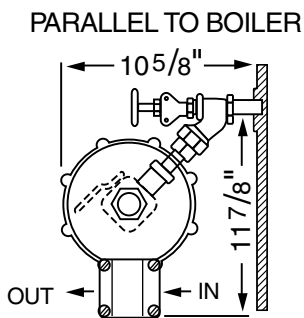

STEP 2 - Preparation (Installing Quick Hook-up Fittings to Water Feeder)

a. Turn the boiler off.

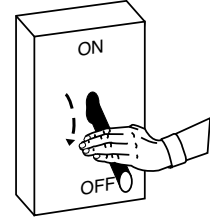

b. Drain the water in the boiler until the level falls below the lower gauge glass connection (A). Allow the boiler to cool to 80°F (27 °C) and allow the pressure to release to 0 psi (0 bar).

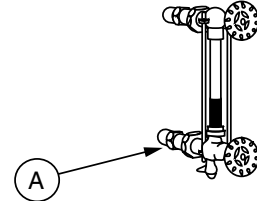

c. Remove the water glass (B) and gauge glass connections (C) from the boiler.

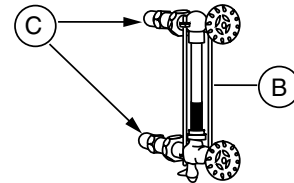

d. Determine the position of the black "Y" casting (F).

If gauge glass tappings (D) and (E) are less than 10 5/8" (270 mm) apart, install the black "Y" casting (F) as depicted in the diagram to the top right.

OR

If gauge glass tappings (D) and (E) are greater than 10 5/8" (270 mm) apart, invert the black "Y" casting (F) as depicted in the diagram to the bottom right.

OR

If gauge glass tappings (D) and (E) are greater than 14" (356 mm) apart, invert the black "Y" casting (F) as depicted in the diagram to the bottom right and install a longer nipple (G).

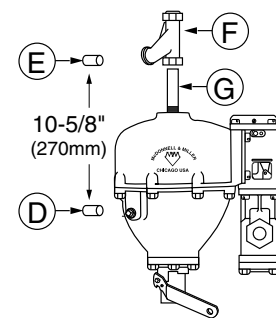

INVERTED "Y" CASTING

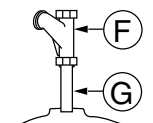

Note:
Reverse union
nuts, packing
and plug.
Tighten top
nut securely.

- e. Remove the plug (H) from the 1/2" (15 mm) NPT tapping (J) in the top of the feeder body (K).

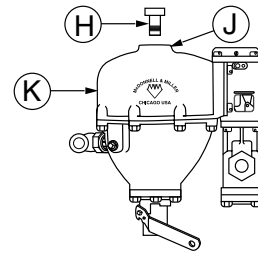

! IMPORTANT



When using pipe or tape sealant on the external threads of pipes or fittings, follow the manufacturers instructions. Use sparingly and do not place on the first thread.

- f. Apply thread sealant to the external threads. Using a pipe wrench, tighten the 1/2" (15 mm) NPT nipple (G) into the tapping (J) on the top of the feeder (K) to approximately 54 ft•lb (74 N•m).

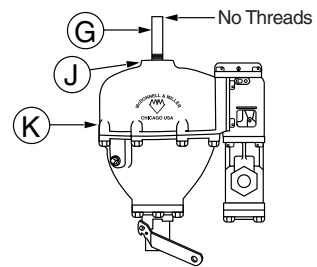

Note: Nipple (G) is only threaded on one end.

- g. Slide the black "Y" (F) casting over the nipple (G) in accordance with Step 2d, but do not tighten.

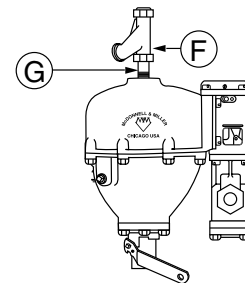

- h. 1). Apply sealant to the external threads of the nipple (L) of the upper "Y" connection. Using a pipe wrench, tighten the nipple (L) into the 1/2" (15 mm) NPT tapping (M) of the black "Y" casting (F). Slide union nut (U) over nipple (L). Using a pipe wrench tighten the upper "Y" connection (N) to nipple (L). Tighten to 54 ft•lb (74 N•m).

- 2). Apply sealant to the external threads of the tailpiece (P) of the lower "Y" connection. Slide union nut (U) over tailpiece (P). Using a pipe wrench, tighten the tailpiece (P) into the 1/2" (15 mm) NPT tapping (Q) in the lower half of body (K). Tighten to 54 ft•lb (74 N•m).

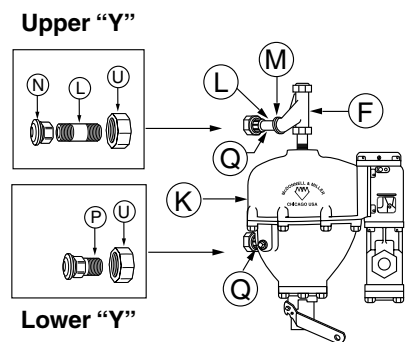

- i. Using the pipe wrench, tighten the furnished pipe plug into the open tapping (R) on the lower half of the feeder float body in accordance with the position diagrams in Step 1. Tighten the plug to approximately 20 ft•lb (27.3 N•m).

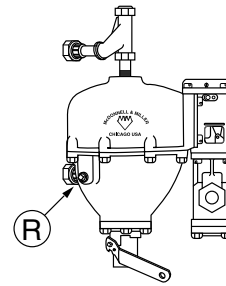

STEP 3 - Installing Series 47 Water Feeder or Series 47-2 Combination Water Feeder/Low Water Cut-Off with Quick Hook-Up Fittings to Boiler

IMPORTANT



When using pipe or tape sealant on the external threads of pipes or fittings, follow the manufacturers instructions. Use sparingly and do not place on the first thread.

- a. Apply thread sealant to the external threads of the "Y" fittings (T). Using the pipe wrench, install them in the boiler gauge glass tapings (S), and tighten to approximately 54 ft•lb (74 N•m).

Tighten both union nuts (U).

- b. Reinstall water glass and gauge connections to "Y" fittings (T).

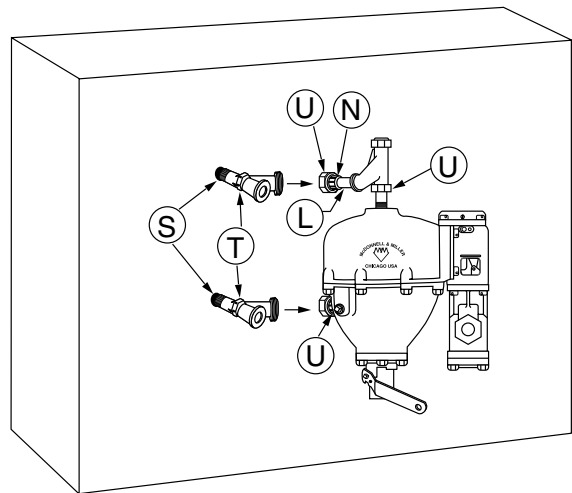

STEP 4 - Installing Series 247/247-2 Water Feeder to Boiler

Pipe the Series 247/247-2 water feeder so that the line on the casting is 3" (76mm) above the minimum safe operating level as specified by the boiler manufacturer.

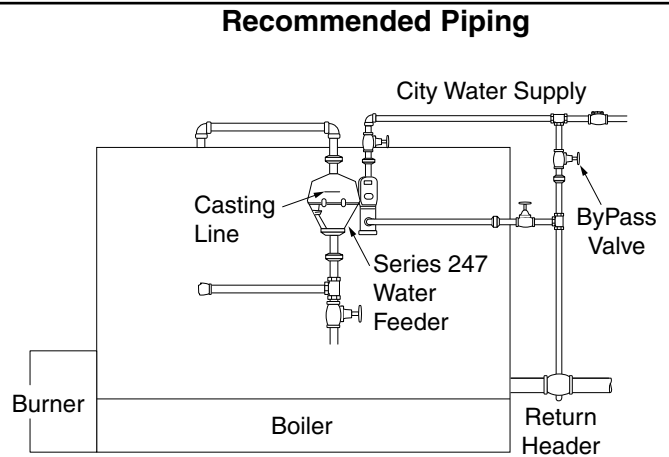

STEP 5 - Piping the valve on the Models 47/47-2 and 247/247-2

- Follow the drawing to the right for piping the valve to the boiler and city water supply. When piping the valve, remember to leave room for servicing the valve.
- Piping the valve this way will aid in troubleshooting the valve and piping in the future.

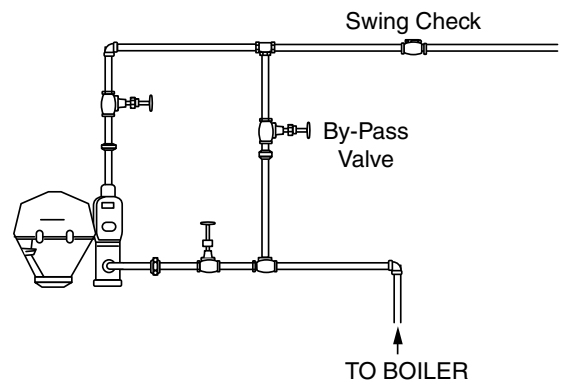

STEP 6 - Electrical Wiring (Only for Series 47-2 & 247-2)

IMPORTANT

Boiler manufacturer schematics should always be followed. In the event that the boiler manufacturer's schematic does not exist, or is not available from the boiler manufacturer, refer to the schematics provided in this document.

- Using the flathead screwdriver, loosen the two (2) screws that secure the switch cover (AA).
Remove cover.

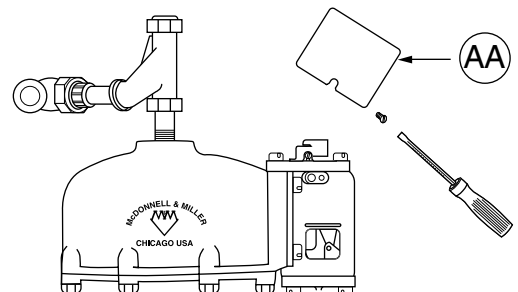

b. Based on the mode of operation required for your application, complete the appropriate corresponding step.

When the water feeder is used as a low water cut-off switch and/or a low water alarm, connect the "Hot" wire to the "Common" contact. Using a flat head screw driver, tighten the screw. Connect the low water alarm to the "Normally Open" contact and tighten the screw. Connect the burner or load circuit wire to the "Normally Closed" contact and tighten the screw.

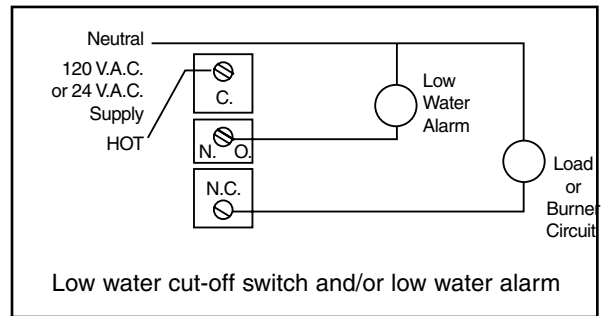

OR

When the water feeder is used as a pilot switch to a holding coil of a motor starter or relay, connect as shown in the diagram to the right.

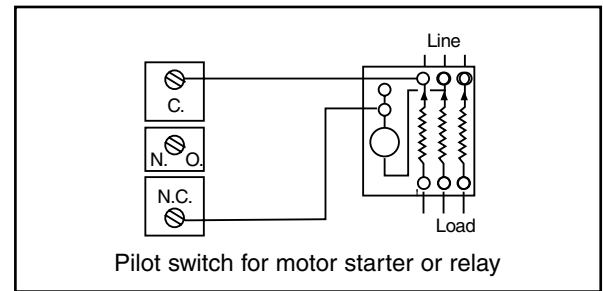

INSTALLATION COMPLETE

STEP 7 - Testing and Inspection

Blow Down of Feeder

CAUTION



To prevent serious personal injury from steam pipe blow down, connect a drain pipe to the control opening to avoid exposure to steam discharge.

Failure to follow this caution could cause personal injury.

The feeder should be blown down after initial installation before leaving site. It should also be blown down as recommended in the Maintenance section of these instructions.

- Burner should be on and water level above 'closing level' of feeder.
- **Slowly** open the water feeder blow down valve 'V' which will lower the water level in the float chamber. As water flows out the blow down pipe, you should begin to hear the feeder valve open.
- If the feeder has a #2 switch, the burner should stop.
- Close the water feeder blow down valve 'V'. The water level should return to a safe operating level and the burner should turn on.

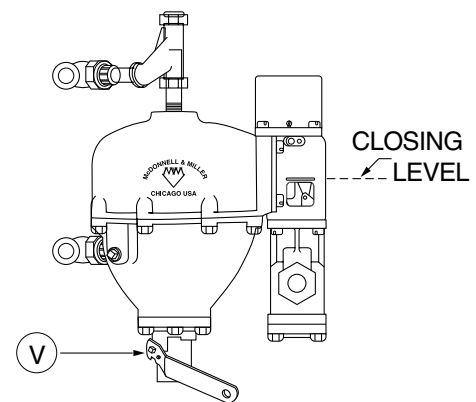

Broken Union Test

Make sure that the water level in the boiler is above the closing level of the feeder.

Close valve 'X' and slowly open union 'Z' to determine if valve is leaking.

- If water is leaking from the union, the valve needs to be serviced.
- If no water leaks from the union, the feeder operation is not the cause of the flooding.

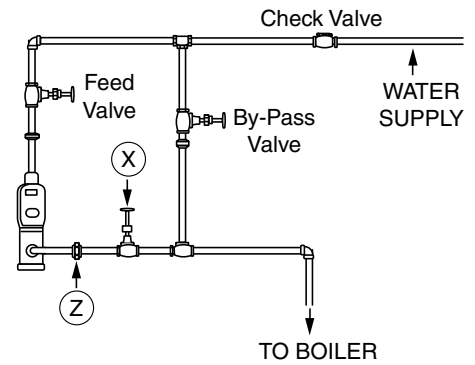

Removal of cartridge and strainer for inspection and cleaning

- Using a 1/2" socket wrench, unscrew the four (4) hex-head bolts (B) that secure the strainer basket (H) to the valve assembly (E).
- Using a 13/16" socket wrench, unscrew the cartridge (D) and remove.
- Clean any debris (scale, rust, etc.) from strainer and cartridge. Poppet inside cartridge must move freely. Replace if debris cannot be removed or poppet does not move freely.
- Lubricate cartridge o-rings using silicone type lubricant and re-install.
- Re-install strainer basket.

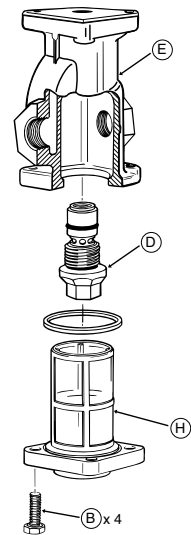

TROUBLESHOOTING

The following is intended as a guide to determine why the feeder may not be operating as intended. Please note that there can be system and installation issues that can affect the operation of the feeder. This includes but is not limited to the following:

- Piping not installed properly
- Faulty check valve in return header
- Tankless coil leaking
- Priming and foaming of boiler water
- Delay in condensate returning to boiler

Boiler is getting too much water.

- a) **Cause:** There is something preventing the valve (cartridge poppet) from completely closing.
Test: Perform broken union test.
Solution: Remove and inspect cartridge. Clean or replace as necessary.
- b) **Cause:** By-pass valve is leaking.
Test: Perform broken union test.
Solution: Repair or replace valve.
- c) **Cause:** Float chamber clogged with sediment.
Test: Open blow-down valve. If there is little or no water flow, the chamber may be clogged with sediment.
Solution: Remove bottom of float chamber. Clean sediment from chamber, float and bellows mechanism. Replace control if necessary.
- d) **Cause:** Float has filled with water.
Solution: Replace float.
- e) **Cause:** Equalizing piping is plugged.
Solution: Clean or replace piping.
- f) **Cause:** Water supply is above 150 psi.
Solution: Install pressure reducing valve to reduce water pressure.

Boiler is not getting enough water.

- a) **Cause:** There is something preventing the valve (cartridge poppet) from fully opening.
Test: Perform broken union test.
Solution: Remove and inspect cartridge. Clean or replace as necessary.
- b) **Cause:** Strainer clogged with sediment.
Test: Perform broken union test.
Solution: Remove and inspect strainer. Clean or replace as necessary.
- c) **Cause:** Float chamber clogged with sediment.
Test: Open blow-down valve. If there is little or no water flow, the chamber may be clogged with sediment.
Solution: Remove bottom of float chamber and clean sediment from chamber, float and bellows mechanism. Replace control if necessary.
- d) **Cause:** Feed line between valve and boiler is partially plugged.
Test: Perform broken union test. With union broken, there should be water flowing through the piping from the boiler.
Solution: Clean or replace piping.
- e) **Cause:** Feed line between valve and city water supply is plugged.
Solution: Clean or replace piping.
- f) **Cause:** Water supply pressure is less than boiler pressure.
Solution: Reduce boiler pressure or convert to pumped return.

TROUBLESHOOTING (cont'd)

Unit is making noise.

a) **Cause:** Under certain system conditions, there may be a vibration when the valve mechanism (cartridge poppet) is slightly open.

Solution: Install a pressure reducing valve, such as the Bell & Gossett B-38, in the inlet water line before the feeder valve.

Burner switch not working.

a) **Cause:** Cam worn or broken.

Solution: Replace cam assembly (CO-106/302900).

b) **Cause:** Linkages not transferring float movement to switch.

Solution:

- Linkage pins may be worn or broken which would require purchasing a new valve assembly (SA47-101-102/341600).
- Float may be damaged, sediment may have accumulated in chamber or equalizing piping may be plugged. Perform testing to determine what the problem may be and correct.

Water leaking from bellows

a) **Cause:** Continuous exposure to chemicals or water with pH higher than 9.0 can cause the solder to deteriorate.

Solution: Remove source of chemicals or consider replacing control with one that is suitable for the application.

MAINTENANCE

SCHEDULE:

Weekly

- Blow down when boiler is in operation.

Annually

- **Disassemble and inspect/clean strainer screen.** Replace if screen is torn or not able to be cleaned.
- **Remove and inspect/clean cartridge.** Replace if poppet does not move freely or debris cannot be removed.
- **Remove lower float chamber and inspect internal parts.** Clean out all mud, silt, sediment and debris from chamber, float mechanism and other waterside components.
- **Inspect equalizing piping.** Clean or replace as required.
- **Check all wires for brittle or worn insulation.**
- **Check for leaks at gasket surfaces and solder joints.**

NOTE
Use clean water to rinse components and surfaces. DO NOT use sharp objects to scrape off any accumulations of sediment or debris.

Replace entire unit including equalizing piping every 10 years.

More frequent cleaning or replacement may be required if used in locations where water treatment is required or in applications with high make-up water requirements.