



Replacement Cartridge and Strainer Kit

For Series:

47, 51, 101-A
247, 551S,
847, 851,

Water Feeders with Hex Port Valves

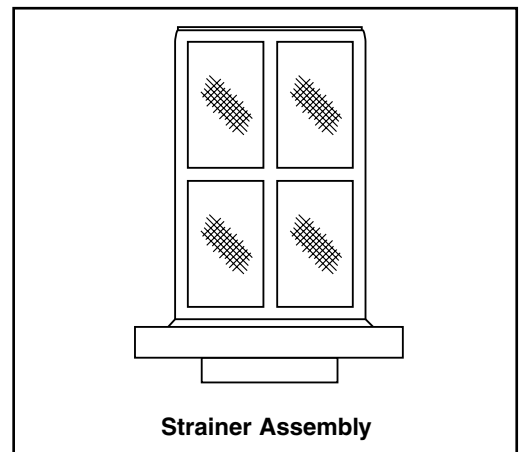
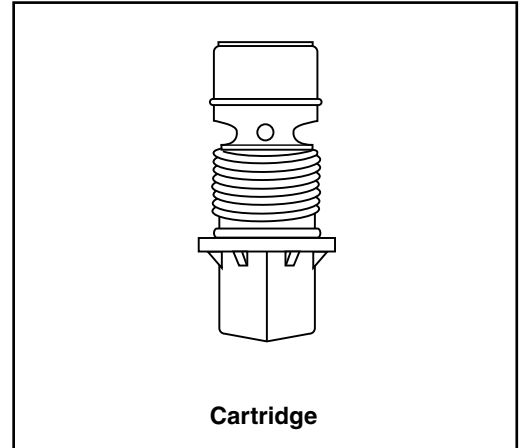

WARNING

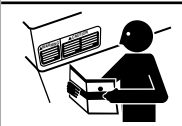

- Before using this product read and understand instructions.

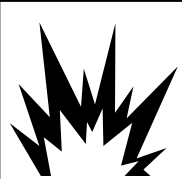

- Save these instructions for future reference.



- All work must be performed by qualified personnel trained in the proper application, installation, and maintenance of plumbing, steam, and electrical equipment and/or systems in accordance with all applicable codes and ordinances.

Failure to follow this warning could cause property damage, personal injury or death.

Engineered for life

INSTALLATION –

TOOLS NEEDED:

One (1) 13/16" (21mm) socket wrench and one (1) 1/2" (13mm) wrench.

STEP 1 - Preparation

- a. Turn off the power to the boiler.

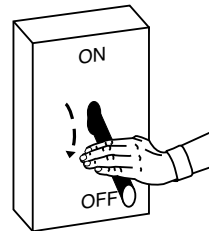

- b. Allow the boiler to cool to 80°F (27°C) and close the two (2) gate valves (A) in the system piping.

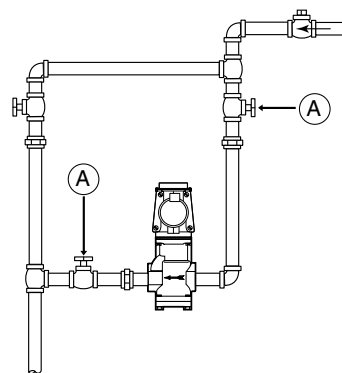

STEP 2 - Remove the Original Cartridge and Strainer

- a. Using the 1/2" (13mm) wrench, unscrew and remove the four (4) hex-head screws (B) that secure the strainer. Discard the strainer (H) and the gasket (C).

- b. Using a 13/16" (21mm) socket wrench, unscrew the old cartridge (D) from the valve body (E) and discard it.

NOTE: The cartridge (D) will either be black (Series 101-A, 47, 247 and 847) or gray (Series 51, 851 and 551-S) and should be replaced with a similarly colored replacement cartridge.

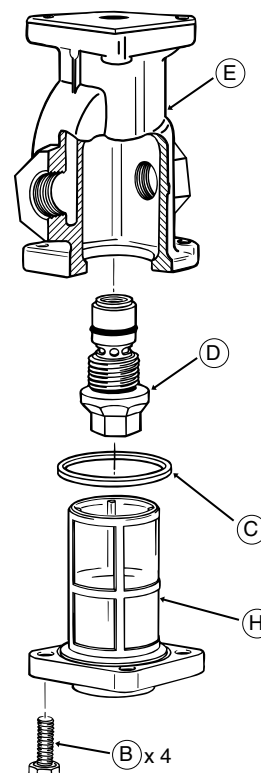

STEP 3 - Install the New Cartridge and Strainer

- a. Apply lubricant (provided) to the two (2) O-rings (E) on the new cartridge (F).

NOTE: Use the silicone grease provided in red capsule. The use of other lubricants may cause premature cartridge failure.

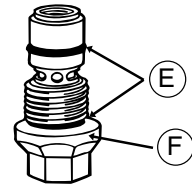

- b. Using the 13/16" (21mm) socket wrench, screw the new cartridge (F) into the valve body (E). Tighten to approximately 2 ft•lb (2.6 N•m). DO NOT OVER TIGHTEN.

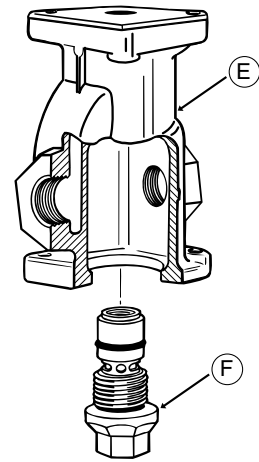

- c. Place the gasket (C) in the groove on the strainer assembly (G) and insert the strainer (H). Using a socket wrench, tighten the four (4) bolts to 8 ft•lb (11 N•m).

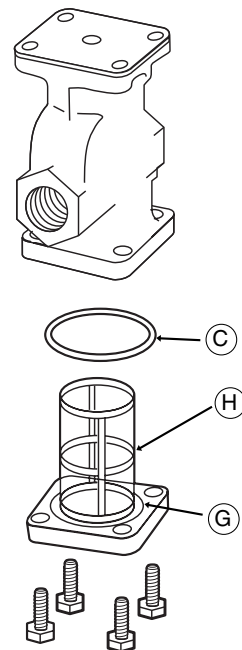

- d. Open the gate valves (A) by turning the handles counter-clockwise.

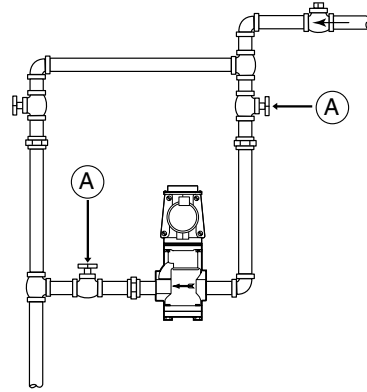

MAINTENANCE

SCHEDULE:

- **Disassemble and inspect the strainer screen annually. Thoroughly clean the strainer screen or replace.**
- **Remove and inspect cartridge annually. Thoroughly clean by rinsing with clear water or replace.**