

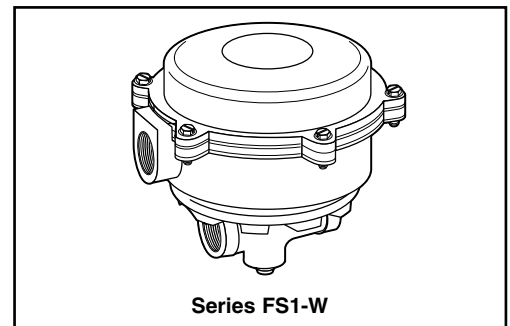

Series FS1
High Sensitivity
Liquid Flow Switch

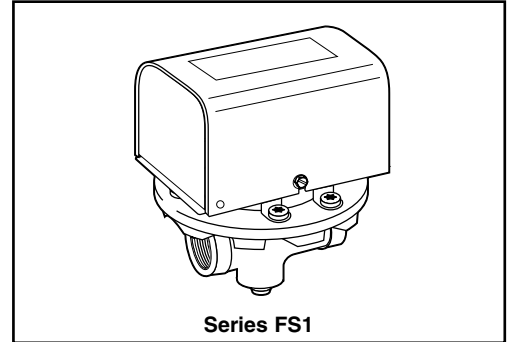





CE (specified models only)



OPERATION

This control is an independently mounted water flow sensing device that makes or breaks an electrical circuit when flow stops or starts.

 WARNING	
	<ul style="list-style-type: none">• Before using product, read and understand instructions.• Save these instructions for future reference.
	<ul style="list-style-type: none">• All work must be performed by qualified personnel trained in the proper application, installation, and maintenance of plumbing, steam and electrical equipment and/or systems in accordance with all applicable codes and ordinances.• To prevent electrical shock, turn off the electrical power before making electrical connections.
	<ul style="list-style-type: none">• To prevent an electrical fire or equipment damage, electrical wiring insulation must have a rating of 167°F (75°C) if the liquid's temperature exceeds 180°F (82°C).• To prevent electrocution, when the electrical power is connected to the flow switch, do not touch the terminals.• Make sure flow switch electrical cover is secured before turning on electric power.
<p>Failure to follow this warning could cause property damage, personal injury or death.</p>	

SPECIFICATIONS

Maximum Liquid Pressure: 100 psi (7 kg/cm²)

Liquid Temperature Range (T_L): 32 - 225°F (0 - 107°C)

Ambient Temperature Range (T_s): 32 - 120°F (0 - 49°C)

Electrical Enclosure Rating: Nema Type 1 (IP 21) (*All models except "W"*)
Nema Type 4X (IP 56) (*"W" models*)

Maximum Velocity: 10ft/sec (3M/sec)

Pipe Connection Thread Size: 1/2" NPT (*All models except "J"*)
1/2" BSPT (*"J" models*)

NOTE: Switch on 'G' models is rated for 750mA @ 24VAC and 24VDC. This switch should only be used on low voltage (24 VAC or less) or millivolt systems.

ELECTRICAL RATINGS

Voltage	Motor Switch Rating (Amperes)		Pilot Duty
	Full Load	Locked Rotor	
120 VAC	7.4	44.4	125 VA at 120 or 240 VAC 50 or 60 cycles
240 VAC	3.7	22.2	

CE Circuit Rating	
7.4 (7.4)/120~	0.3/120=
3.7 (3.7)/240~	0.15/240=

Models that meet CE Conformance:

FS1-J-E

FS1-W-E

- **This Control:** is for continuous operations
is not electronic
has Type 1C action (micro interruption on operation)

- **LVD 73/23/EEC**

- **EMC 89/33/EEC**

For applications with loads between 0.5 and 3.7 Amps, power factors exceeding 0.65, an anticipated system switch operation rate of less than once per 2.5 minutes, and any one cycle greater than 3 seconds on and 3 seconds off.

For applications with loads 0.5 and 38mA, power factors exceeding 0.65, an anticipated system switch operation rate of less than once per 5 minutes, and any one cycle greater than 3 seconds on and 3 seconds off.

Additional suppression may be required for applications outside these ranges.

- **Declaration of Conformity**

Available on request.

FLOW RATES

Flow rates required to activate flow switch are shown in chart below. The values are calculated for sensing water (potable, non-polluted) in a horizontal pipe.

Settings will vary when used to sense flow of other fluids.

Flow Rates

Settings	Mode of Operation		Max. Flow Rate gpm (lpm) w/o Paddle Damage
	Flow gpm (lpm)	No Flow gpm (lpm)	
Factory or Minimum	0.41 (1.55)	0.24 (.91)	25
Maximum	1.81 (6.85)	1.28 (4.84)	(95)

NOTE: DO NOT USE LIQUID FLOW SWITCHES ON SYSTEMS WITH FLOW VELOCITY GREATER THAN 10 FEET (3M) PER SECOND.

Values are ± 10%

NOTE: “L” models are set at the factory to prove flow at 1.7 gpm. The setpoint should not be adjusted in the field without consulting factory.

PSI Flow Switch Capacity - FSI

ΔP DIFFERENTIAL PRESSURE	10	20	30	40	50	60	70	80	90
GPM CAPACITY	8.35	11.50	13.60	15.75	17.75	19.75	21.25	23	24.25

INSTALLATION –

STEP 1 - Determine the Location of the Flow Switch

- The flow switch **should be located in a horizontal section of pipe** where there is a straight horizontal run of at least 5 pipe diameters on each side of the flow switch.
- The flow switch **must be installed in the upright position** as shown with arrow mark on side of casting in the same direction as fluid will flow.
- Some system conditions that require more than 5 pipe diameters are high viscosity fluid and high fluid velocity.

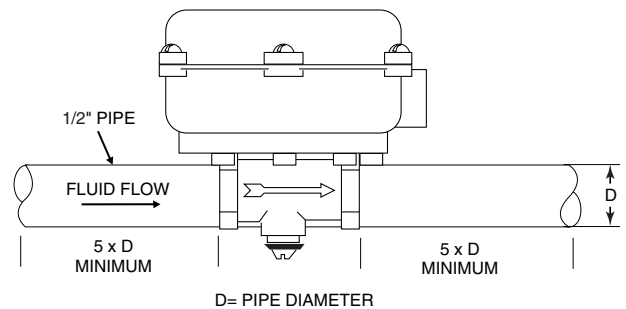

STEP 2 - Connecting the Flow Switch to Pipe

- a. Apply pipe sealing compound or Teflon® tape to the pipe threads.

NOTE: Do not apply sealant to first threads as this switch is grounded (earthed) via the pipe mounting.

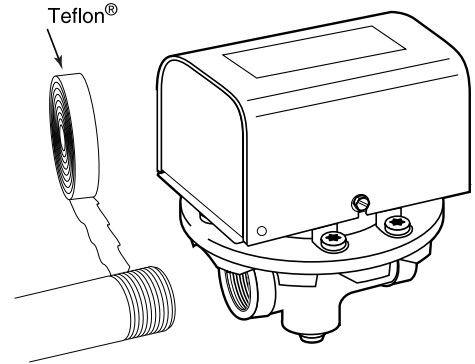

- b. Insert pipe threads into flow switch and turn 2 or 3 times until tight.
- Place one pipe wrench on hex fitting of flow switch and one wrench on connecting piping. Tighten to following torque values.
 - 31 ft•lb (42 N•m) for 1/2" pipe
 - Repeat to connect pipe to opposite side of flow switch.

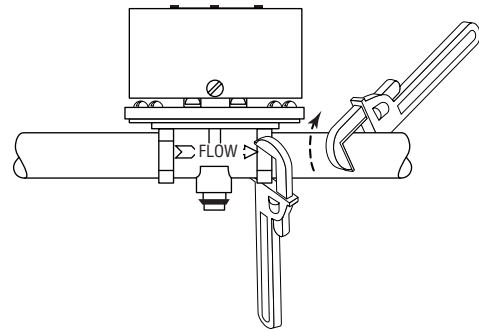

STEP 3 - Electrical Installation

WARNING



- To prevent electrical shock, turn off the electrical power before making electrical connections.
 - To prevent an electrical fire or equipment damage, electrical wiring insulation must have a rating of 167°F (75°C) if the liquid's temperature exceeds 180°F (82°C).
 - To prevent electrocution, when the electrical power is connected to the flow switch, do not touch the terminals.
 - Make sure flow switch electrical cover is secured before turning on electric power.
- Failure to follow this warning could cause property damage, personal injury or death.

a. Cover Removal and Installation Procedure

For FS1 models with NEMA 1 Enclosure

- Using a flathead screwdriver, loosen but do not remove the two cover screws and remove the cover (A).
- Place the cover on the flow switch sliding the slots behind the two loose cover screws. Push the cover down into the flow switch and using a flat blade screwdriver, tighten the cover screws to a torque of 10 lb•in (1.13 N•m).

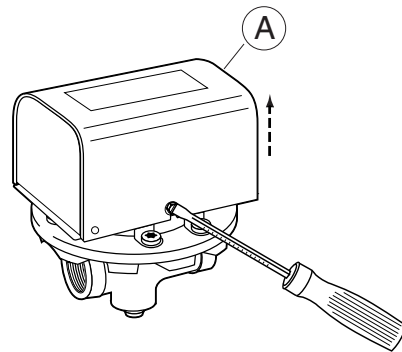

For FS1-W models with NEMA 4X Enclosure

- Using flathead screwdriver, unscrew the six cover screws and remove cover.
- Place the electrical connection cover on the flow switch and insert the six cover screws. Tighten the screws to a torque of 10 lb•in (1.13 N•m).

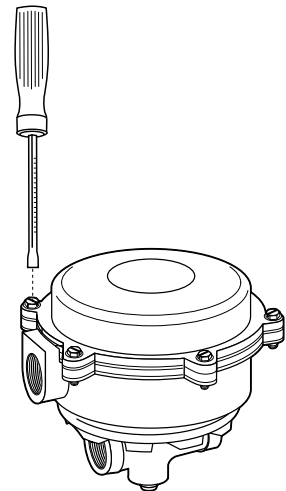

b. Electrical Conduit Connection

- Connect electric conduit to flow switch electrical enclosure.
- Follow accepted electrical practices when installing fittings and making connections.
- Refer to and follow local codes and standards when selecting the types of electrical fittings and conduit to connect to flow switch.

c. Determine which switch action is required for the flow switch.

- “Flow” means that the switch will close circuit C.-N.O. and open circuit C.-N.C. when flow rate is increased above setpoint of flow switch.
- “No Flow” means that the switch will open circuit C.-N.O. and close circuit C.-N.C. when flow rate is decreased below setpoint of flow switch.

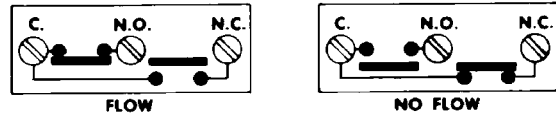

d. Based upon the mode of operation (“Flow” or “No-Flow”) required, complete the appropriate steps to connect wires to flow switch. Use a Phillip’s head screwdriver to loosen and tighten switch terminal screws when attaching wires.

For “Flow” Mode of Operation (Fig. 1)

If the flow switch will be used to actuate a signal, alarm or other device when **flow** occurs, connect the wire from that device to the “N.O.” contact. Connect the “Hot” power supply wire to “C” terminal.

For “No Flow” Mode of Operation (Fig. 2)

If the flow switch will be used to actuate a signal, alarm or other device when **no flow** occurs, connect the wire from that device to the “N.C.” contact. Connect the “Hot” power supply wire to “C” terminal.

NOTE: Do not adjust these screws.

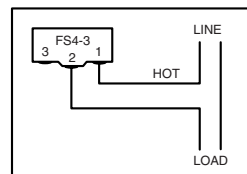
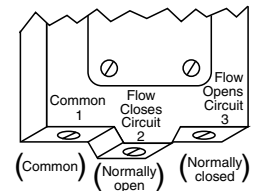
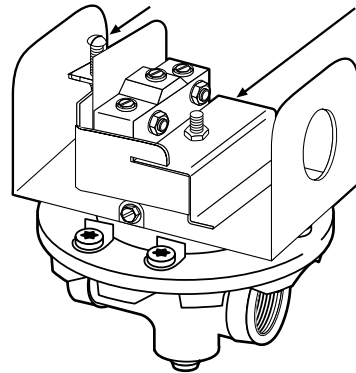

Fig. 1

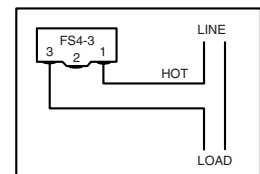
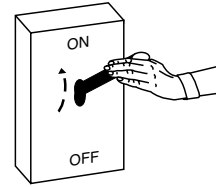

Fig. 2

SECTION 4 - Testing

- a. Place cover on flow switch and turn on power. Initiate fluid flow through the system. Observe the device being activated by the flow switch to determine if device is operating as required.
- b. Turn off fluid flow to determine if device is operating as required.
- c. Repeat initiating and turning off fluid flow several times to test flow switch and device for proper operation.
 - If operating as required, put system into service.
 - If not operating as required, flow switch may need to be adjusted.



STEP 5 - Adjustment

Adjustment is necessary only if required flow/no flow setpoints are **above** factory set minimum.

- a. Turn off power.
- b. Locate adjusting screw on bottom of unit.
- c. Turn adjusting screw clockwise (1/8 turn) to increase setpoint.

IMPORTANT: Do not attempt to lower flow switch setpoint from original factory minimum setting. Lowering (turning adjusting screw counterclockwise) the setpoint from original factory setting may cause erratic flow switch operation.

- d. Turn on power.
- e. Test the operation of the flow switch after each adjustment.

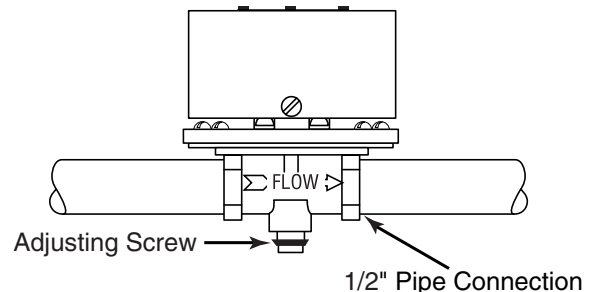



MAINTENANCE

SCHEDULE:

- **Inspect annually.** Turbulent or high flow velocity conditions may require more frequent inspection and/or replacement.
- **Replace flow switch every 5 years or 100,000 cycles, whichever occurs first.**

McDonnell & Miller

TROUBLESHOOTING

Problem:

1. Flow Switch Does Not Operate

Solution:

- a. Make sure power has been turned on to device and flow switch.
- b. Verify that flow rate is high enough for flow switch to activate. Measure flow rate and match with velocities shown in flow rate chart.
- c. Flow switch may be located to sense flow in polluted (scale, rust, sludge, etc.) water. Relocate switch to a pipe that senses flow of non-polluted water.

2. Flow Switch Operates Erratically

Solution:

- a. Adjustment screw may have been turned below original factory setpoint. Verify that flow rate is high enough for flow switch to activate. Measure flow rate and match with velocities shown in flow rate chart.
- b. Flow switch may be located to sense flow in polluted (scale, rust, sludge, etc.) water. Relocate switch to a pipe that senses flow of non-polluted water.

3. Flow Switch Does Not Deactivate

Solution:

- a. Measure flow rate and match with velocities shown in flow rate chart. Flow switch must prove flow before it can indicate no flow.
- b. Flow switch may be located to sense flow in polluted (scale, rust, sludge, etc.) water. Relocate switch to a pipe that senses flow of non-polluted water.