

Safgard™

Model 1150

**Low Water Cut-Off
For Residential
Hot Water Boilers**

120 VAC Operating Voltage

- ADVANCED SOLID STATE DESIGN
- TEST BUTTON FOR EASY DIAGNOSTICS
- POWER AND LOW WATER LED INDICATORS
- COMPACT SIZE ALLOWS FOR MOUNTING IN TIGHT SPACES
- DESIGNED FOR GAS AND OIL FIRED BOILERS



WARNING: To prevent electrical shock or equipment damage, power must be off during installation or servicing of the control. To prevent serious burns, the boiler should be thoroughly cooled before installing or servicing control. Only qualified personnel may install or service the control in accordance with local codes and ordinances. Read instructions completely before proceeding.

Step 1

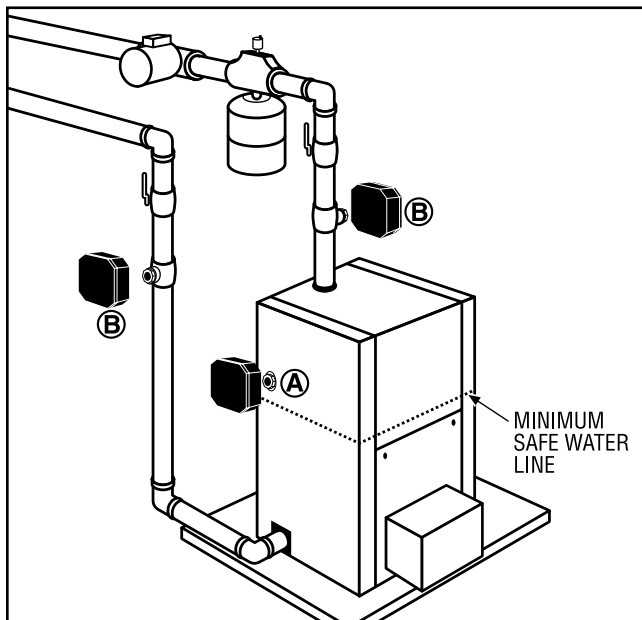

Determine Mounting Location

The Safgard 1150 must be installed at or above the minimum safe water level established by the boiler manufacturer. The 1150 can be installed directly into the boiler if a suitable tapping is available (A). The 1150 can also be installed in the boiler piping using a standard 3/4" tee (B).

IMPORTANT: Check for adequate clearance (minimum 1/4") from metal probe sensor to any surface inside the boiler or pipe.

Do not install in a location that could hold or trap water in the event of a low water condition.

Step 2

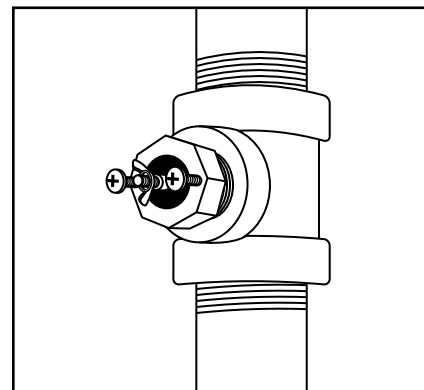

Apply pipe sealing compound to probe threads and install in boiler or tee. Tighten so that the mounting screws are horizontally aligned.

Step 3

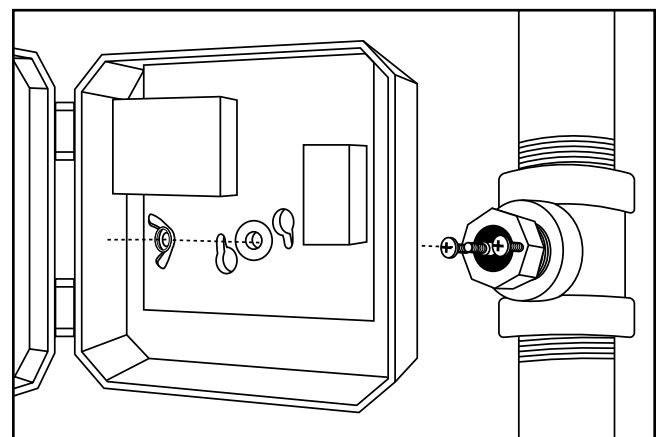

Remove wing nut from the probe terminal. Mount the control box on the probe by aligning the keyhole slots with the mounting screws. Replace the wing nut. Secure the control box by tightening wing nut and two mounting screws.

IMPORTANT: Wing nut and mounting screws must be tightened securely for proper grounding.

**HYDROLEVEL
COMPANY**

STANDARD WIRING METHOD

USE WIRE NUTS FOR ALL CONNECTIONS

This wiring method will shut down all power to the boiler in the event of a low water condition.

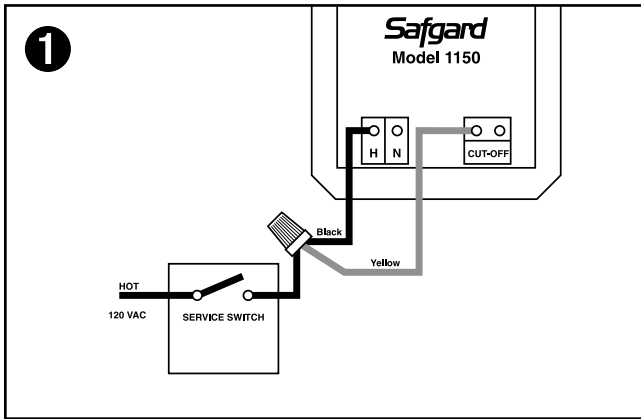

Step 1 Connect the black wire (H) and one of the yellow wires (CUT-OFF) from the Safgard 1150 to the hot 120 VAC lead coming from the service switch.

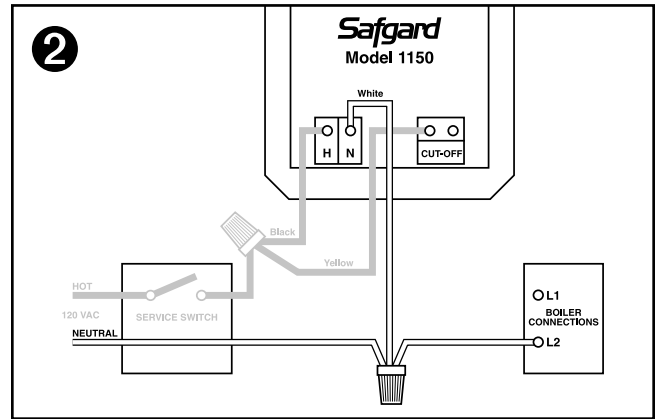

Step 2 Connect the white wire (N) from the Safgard 1150 to the neutral 120 VAC lead and to the (L2) boiler connection.

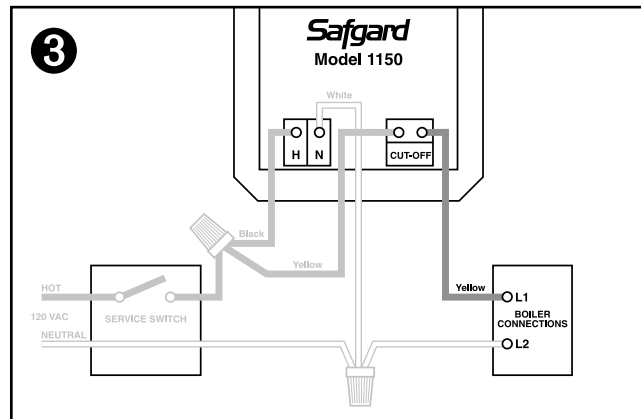

Step 3 Connect the second yellow wire (CUT-OFF) from the Safgard 1150 to the (L1) boiler connection.

OPTIONAL WIRING METHOD

USE WIRE NUTS FOR ALL CONNECTIONS

This wiring method will interrupt power only to the burner circuit in the event of a low water condition.

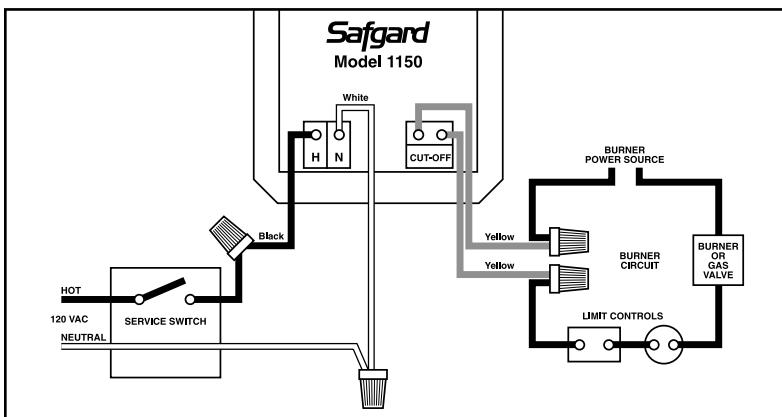

Connect the black wire (H) from the Safgard 1150 to the hot 120 VAC lead coming from the service switch. Connect the white wire (N) to the neutral 120 VAC lead. Locate and break into the burner circuit. Connect the yellow wires (CUT-OFF) from the Safgard 1150 in series with other limit controls as shown.

OPERATIONAL TEST PROCEDURE

IMPORTANT: Do not run boiler unattended until the following procedure is completed

1. Before raising the water level above the Model 1150, turn on power to the boiler and set the thermostat to call for heat. Both the green "POWER" LED and amber "LOW WATER" LED should illuminate. The burner should not fire. **IMPORTANT:** If the burner fires with no water at the probe, immediately shut down power to the boiler and refer to the Trouble Shooting instructions below.
2. Proceed to fill the boiler with water. When water reaches the LWCO position, the burner should fire. If the burner does not fire, refer to the Trouble Shooting instructions below.
3. Turn off the power to the boiler and finish filling the system.
4. Before leaving the job, power up the system and push the TEST button on the Model 1150 to simulate a low water condition. The amber "LOW WATER" LED should illuminate and the burner should shut down.

MAINTENANCE

- EVERY YEAR** Check control operation annually by pressing the TEST button. The amber "LOW WATER" LED should illuminate and the burner should shut down.
- 5 YEARS** Remove the low water cut-off every five years and clean all surfaces in contact with water.

TROUBLE SHOOTING

IF THE BURNER DOES NOT SHUT DOWN

(when water is below the probe or when the TEST button is pressed)

1. Turn off boiler power immediately and re-check wiring.
2. Turn off boiler power and drain system. Remove low water cut-off and check for adequate clearance – no metal should be in contact with the control's metal probe tip.

IF THE BURNER DOES NOT FIRE

1. Make sure water has reached the level of the control.
2. Check for proper ground. The 1150 grounds through the probe to the boiler shell or pipe tee. The control box mounting screws ground the circuit board to the probe. Check to ensure that both mounting screws are tightened securely and that the probe is not insulated from the boiler shell or tee with excessive use of Teflon tape or sealing compound.
3. Check to ensure the control's metal probe tip is not surrounded by an air pocket. Shut down power to the boiler and slowly loosen, but do not remove, the control. Allow any air to escape. When water begins to seep past threads, retighten the control.
4. Re-check wiring and check for correct incoming voltage.

DIMENSIONS

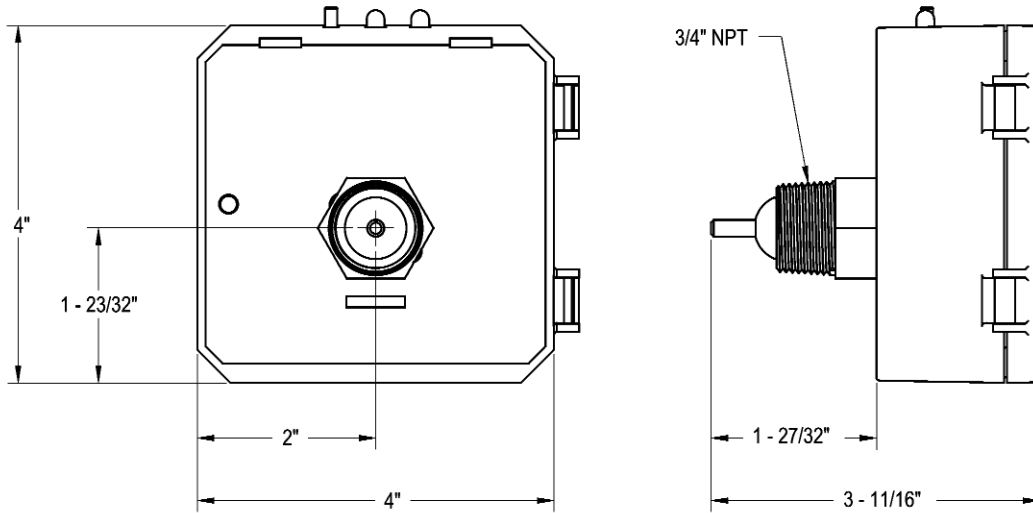

SPECIFICATIONS

VOLTAGE	120 VAC, 60 HZ
BURNER CONTACTS	5.8 FLA, 34.8 LRA, 125 VA pilot duty @ 120 VAC, 60 HZ
MAX PRESSURE	160 PSI
MAX WATER TEMPERATURE	250°F (121°C)

 LISTED

LIMITED MANUFACTURER'S WARRANTY

We warrant products manufactured by Hydroleval Company to be free from defects in material and workmanship for a period of two years from the date of manufacture or one year from the date of installation, whichever occurs first. In the event of any claim under this warranty or otherwise with respect to our products which is made within such period, we will, at our option, repair or replace such products or refund the purchase price paid to us by you for such products. In no event shall

Hydroleval Company be liable for any other loss or damage, whether direct, indirect, incidental or consequential. This warranty is your EXCLUSIVE remedy and shall be IN PLACE OF any other warranty or guarantee, express or implied, including, without limitation, any warranty of MERCHANTABILITY or fitness for a particular purpose. This warranty may not be assigned or transferred and any unauthorized transfer or assignment thereof shall be void and of no force or effect.