

**Models 912, 913, 918 and 919 ASME Section VIII,
Air/Steam/Gas/Liquid, “UV” National Board Certified.
Also available for Vacuum Service.
PED Certified for Non-Hazardous Gas.**



Model 912



Features

- Available with soft seat.
- Threaded cap is standard (back pressure tight).
- Hex on valve nozzle provides for easy installation.
- Warn ring offers easy adjustability.
- Pivoting disc design corrects misalignment and offers exceptional performance.
- Guide to nozzle ratio reduces friction.
- Full nozzle design for optimum flow performance.
- Threaded side outlet for piped off discharge to eliminate fugitive emissions.

Model Descriptions

Model 912: Full nozzle design. Stainless Steel (SS) warn ring and disc with brass/bronze base. Bronze/brass body and bonnet.

Model 913: Full nozzle design. Bronze/brass body and bonnet. 316 SS trim (base, disc and disc holder).

Model 918: Same as model 912 except resilient seat/seal. Superior “leak-free” performance. FM approved with 316 SS base for fire pump installations in “BDD” and “BDE” sizes².

Model 919: Same as model 913 except resilient seat/seal. Superior “leak-free” performance. Bronze body and bonnet. 316 SS trim (base, disc and disc holder).

Applications

- Air/gas compressors - intercoolers - aftercoolers.
- Liquid filled pressure vessels/systems - ASME Section VIII (UV).
- Pressure vessels - containing gas, air, liquid or steam. Including tanks and receivers.
- Vacuum systems including pumps, tanks and equipment.
- Optional materials for low temperature - cryogenic applications.
- Oil/gas separators.
- Overpressure relief and protection of pumps, tanks, lines and hydraulic systems.
- By-pass relief or pressure regulation.

Options

- Threaded cap. (variation 01)
- Threaded cap with gag. (variation 02)
- Plain lever. (variation 03)
- Plain lever with gag. (variation 04)
- Plain lever with vibration dampener. (variation 05)
- Packed lever. (variation 06)
- Packed lever with gag. (variation 07)

Pressure and Temperature Limits

Models 912, 918: – Steam
3 to 250 psig [0.2 to 17.2 barg]¹
-320° to 406°F [-195° to 208°C]

Models 913, 919: – Steam
3 to 300 psig [0.2 to 20.7 barg]¹
-320° to 425°F [-195° to 219°C]

Models 912, 918: – Air/Gas/Liquid
3 to 300 psig [0.2 to 20.7 barg]
-320° to 406°F [-195° to 208°C]

Models 913, 919: – Air/Gas/Liquid
3 to 1400 psig [0.2 to 96.5 barg]
-320° to 425°F [-195° to 219°C]

Vacuum – 6” to 29” HG
[200 to 1000 mbar] – 300°F [149°C]

Maximum back pressure 50 psig [3 barg]
- threaded cap and packed lever³

Notes

1. ASME standard valves for air or steam service must have lift lever. For steam boilers and generators.
2. Requires Variation 08 for specific set pressure or variations listed below for adjustable relief pressure settings:
Variation 10: 60 - 125 psig [4.1 - 8.6 barg],
Variation 11: 125 - 175 psig [8.7 - 12 barg],
or
Variation 12: 176 - 250 psig [12.1 - 17.2 barg]
3. Back pressure increases set pressure on a one to one basis, and reduces capacity. Back pressure in excess of 10% of set pressure is not recommended.

Specifications - Models 912, 913, 918, and 919

Models 912, 913, 918, 919 ASME Section VIII, Steam/Air/Gas/ Liquid, "UV" National Board Certified.
Also available for Vacuum Service

Service Recommendations for Resilient Seat/Seal Materials

Seat/Seal Materials ¹	Service Recommendation
BUNA-N (-30° to 275°F) [-40° to 135°C]	Air, Anhydrous Ammonia, Butane, Carbon Dioxide, Diesel Oil, Ethyl Chloride, Ethyl Ether, Freons #11 and 12, Fuel Oil, Gasoline, Helium, Hydrogen Sulphide, Kerosene, Lube Oil, Natural Gas, Nitrogen, Oxygen (Gas), Propane, Propylene, Sulphur Dioxide, Vinyl Chloride
Viton® A (-15° to 406°F) [-26° to 208°C]	Acetone, Air, Amyl Alcohol, Aniline, Benzene, Butane, Carbon Disulphide, Carbon Tetrachloride Dowtherm "A" and "E," Ethyl Chloride, Ethylene, Ethylene Glycol, Ethyl Alcohol, Gasoline, Hexane, Hydrogen Sulphide, Isobutyl Alcohol, JP - 4 Fuel, JP - 5 Fuel, Kerosene, Lube Oil, Natural Gas, Naphtha, Nitrogen, Propane, Propylene, Propyl Alcohol, Sulphur Dioxide, Toluene, Trichloroethylene, Turpentine, Water, Xylene
Silicone (-100° to 406°F) [-73° to 208°C]	Air, Helium, Nitrogen, Oxygen (Gas)
Ethylene Propylene (-70° to 400°F) [-57° to 205°C]	Steam, Hot Water
Neoprene (-45° to 300°F) [-43° to 149°C]	Air, Anhydrous Ammonia, Butane, Butyl Alcohol, Castor Oil Denatured Alcohol, Ethanol, Ethyl Alcohol, Freons (12, 13, 14 and 22), Glycols, Natural Gas and Silicate Esters

Note

- These recommendations are a guide only. For the final selection of the proper material, your experience with available elastomers of various lading fluids should be considered.

Specifications

Model ² Number	Orifice	Connections		Maximum Set Pressure		Dimensions, in [mm]						Approx. Weight lb [kg]
		ANSI Standard Inlet	ANSI Standard Outlet	912-918 ⁴	913-919 ⁵	A	B	C Plain Lever	C Threaded Cap	C Packed Lever		
9*BDC	D	1/2" [12.7]	3/4" [19.0]	300 [20.7]	1400 [96.5]	2 3/8 [60]	1 5/8 [41]	8 3/8 [213]	7 1/4 [184]	9 [229]	3 [1.4]	
9*BDC ⁷	D	1/2" [12.7]	1" [25.4]	300 [20.7]	1400 [96.5]	2 3/8 [60]	1 5/8 [41]	8 3/8 [213]	7 1/4 [184]	9 [229]	3 [1.4]	
9*BDD ³	D	3/4" [19.0]	3/4" [19.0]	—	1400 [96.5]	2 3/8 [60]	1 5/8 [41]	8 3/8 [213]	7 1/4 [184]	9 [229]	3 [1.4]	
9*BDD ^{3,8}	D	3/4" [19.0]	1" [25.4]	—	1400 [96.5]	2 3/8 [60]	1 5/8 [41]	8 3/8 [213]	7 1/4 [184]	9 [229]	3 [1.4]	
9*BDE ³	D	1" [25.4]	1" [25.4]	—	1400 [96.5]	2 5/8 [67]	1 5/8 [41]	8 5/8 [219]	7 1/2 [191]	9 1/8 [232]	3 [1.4]	
9*BED	E	3/4" [19.0]	1 1/4" [31.8]	300 [20.7]	1000 [68.9] ⁹	2 5/8 [67]	2 [51]	8 3/4 [222]	7 5/8 [194]	9 3/8 [238]	4 [1.8]	
9*BEF ³	E	1 1/4" [31.8]	1 1/4" [31.8]	—	1000 [68.9] ⁹	3 [76]	2 [51]	9 1/8 [232]	8 [203]	9 3/4 [248]	4 [1.8]	
9*BFE	F	1" [25.4]	1 1/2" [38.1]	300 [20.7]	700 [48.3] ¹⁰	2 7/8 [73]	2 3/8 [60]	9 7/8 [251]	8 3/4 [222]	10 1/2 [267]	6 [2.7]	
9*BFG ³	F	1 1/2" [38.1]	1 1/2" [38.1]	—	700 [48.3] ¹⁰	3 [76]	2 3/8 [60]	10 [254]	8 7/8 [225]	10 5/8 [270]	6 [2.7]	
9*BGF	G	1 1/4" [31.8]	2" [50.8]	300 [20.7]	600 [41.4]	3 1/4 [83]	2 5/8 [67]	11 1/4 [286]	10 1/8 [257]	11 3/4 [298]	8 [3.6]	
9*BGH ³	G	2" [50.8]	2" [50.8]	—	600 [41.4]	3 1/4 [83]	2 5/8 [67]	11 1/4 [286]	10 1/8 [257]	11 3/4 [298]	8 [3.6]	
9*BHG	H	1 1/2" [38.1]	2 1/2" [63.5]	300 [20.7]	500 [34.5]	3 1/2 [89]	2 3/4 [70]	13 [330]	11 1/8 [283]	12 1/2 [318]	11 [5.0]	
9*B ⁶ JH	J ⁶	2" [50.8]	3" [76.2]	300 [20.7]	500 [34.5] ¹¹	4 [102]	3 1/4 [83]	14 1/2 [368]	12 1/2 [318]	15 1/8 [384]	15 [6.8]	

Dimensions are for reference only.

Notes

- Maximum temperature controlled by resilient seat/seal material.
- Replace asterisk with desired Model Number. Data applicable to all models.
- Available with SS trim (models 913 and 919) only.
- Maximum pressure on steam is 250 psig.
- Maximum pressure on steam is 300 psig.
- For C dimensions: pressures above 200 psig [14 barg] add 1.25" [31.8 mm] to the overall height.
- Special variation required (12 - Threaded Cap, 13 - Threaded Cap with gag, 14 - Plain Lever, 17 - Packed Lever).
- Special variation required (13 - Threaded Cap, 14 - Plain Lever, 17 - Packed Lever).
- 900 psig for liquid service or high temp alloy spring.
- 600 psig for liquid service or high temp alloy spring.
- 367 [25.3] for plain lever with gag.

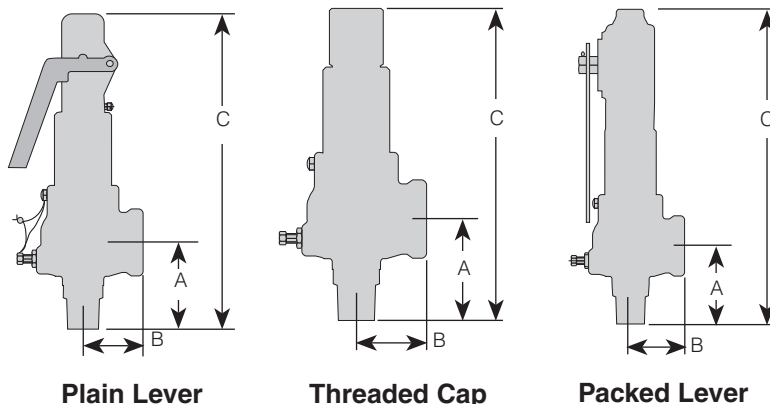

Specifications - Models 912, 913, 918, and 919

Models 912, 913, 918, 919 ASME Section VIII, Steam/Air/Gas/ Liquid, "UV" National Board Certified. Also available for Vacuum Service

Parts and Materials - Models 912, 913, 918, 919 Threaded Cap

No.	Part Name	Materials
1	Nozzle ²	Brass, B21 or B283 Alloy 485, (SS, SA351-CF8M ⁵ Models 913, 919 only)
2	O-ring Body ⁶	Teflon [®]
3	Body	Bronze, B584 Alloy 84400
4	Warn Ring	SS, A743-CF8M
5	Disc ¹	SS, A479-316
6	Set Screw Nut	SS 18-8
7	Set Screw	Brass, B16
8	Seal	Teflon [®]
9	Retainer Ring	SS, A313-316
10	Disc Holder	Brass, B16, (SS A351-CF8M Models 913, 919 only)
11	Guide ³ Guide Lock Nut ⁷ Shield ⁷	Brass, B16 Brass, B16 SS, A167-316
12	Bonnet O-ring ⁶	Teflon [®]
13	Screw	SS, Commercial 18-8
14	Coiled Spring Pin	SS, A313-302
15	Spring	SS: A313-316 or A313-T631/Alloy steel: A681-H12 or B637-X750
16	Bonnet ⁴	Brass, B16-H02
17	Spring Step	Brass, B16
18	Stem	Brass, B16
19	Wire and Seal	SS wire and lead seal, Commercial
20	Cap	Brass, B16
21	Compression Screw	Brass, B16
22	Jam Nut	SS 18-8 or Brass, B16
23	Cap O-ring	BUNA-N
24	Body Plug	Brass, B16 [1/4" - 18 NPT]
25 ⁹	Gag Screw	Steel A108-1018/Zinc Plated
26 ⁹	Gag Screw Plug	SS 18-8
27 ⁹	Gag Screw Gasket	Teflon [®]

Parts and Materials - Models 918 and 919 Soft Seat, F to J Orifice

No.	Part Name	918	919
8	Disc	SS A479-316	SS A479-316
9	Ring, Retainer	SS A313-316	SS A313-316
10	Disc Holder	Brass, B16	SS A351-CF8M
33	Molded Seat ¹		

Parts and Materials - Models 918 and 919 Soft Seat, D and E Orifice

No.	Part Name	918	919
34	Spindle	Brass, B16	SS A479-316
35	Disc Holder	Brass, B16	SS A479-316
36	Retainer	Brass, B16	SS A479-316
37	O-ring Seat ¹		
38	Seat Retainer Screw	SS 18-8	SS 18-8

Notes

- Material Letter Designation
BUNA-N - B
Ethylene Propylene (EPR/EPDM) - E
Neoprene - N
Silicone - S
Viton[®] - V
- F through J orifice nozzle material is Bronze, B62.
- G through J orifice guide material is Bronze, B584, Alloy 84400.
- F through J orifice bonnet material is Bronze, B584, Alloy 84400.
- "D" and "E" orifice, 9*BFG, and 9*BGH nozzle material is SS, SA479-316.
- For threaded cap and packed lever only.
- For "J" orifice only (not shown).
- Gag screw ships with valve, not installed.
- For threaded cap and packed lever gag option only.

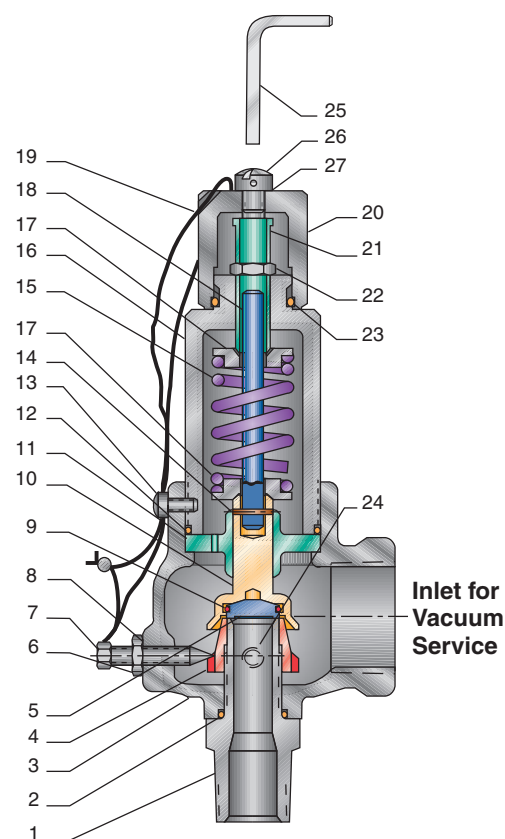

**Metal Seat
Threaded Cap Option
(shown with Gag Option)**

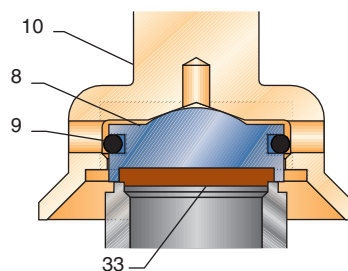

Soft Seat F to J Orifice

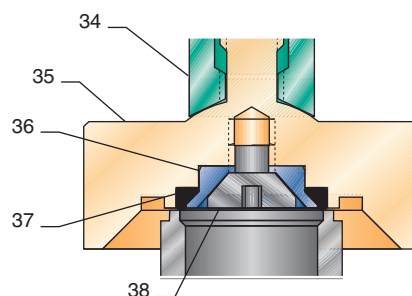

Soft Seat D and E Orifice

Specifications - Models 912, 913, 918, and 919

Models 912, 913, 918, 919 ASME Section VIII, Steam/Air/Gas/Liquid, "UV" National Board Certified. Also available for Vacuum Service

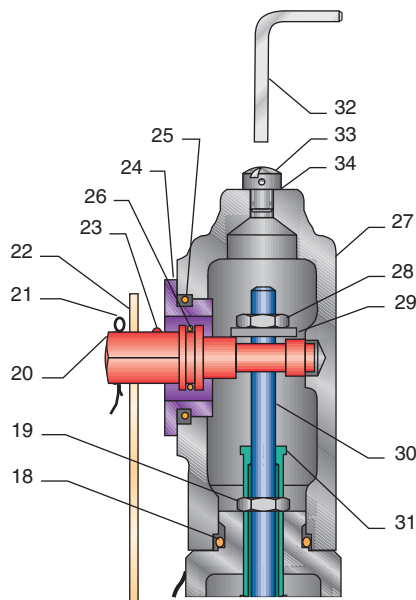

**Packed Lever
(shown with Gag Option)**

Parts and Materials - Model 912 Packed Lever

No.	Part Name	Materials
18	Cap O-ring	BUNA-N 70 Duro, Commercial
19	Jam Nut	Brass, B16
20	Lift Cam	SS, A743 CF8M
21	Cotter Pin	Steel, Commercial
22	Lever	Zinc Plated Steel, A108
23	Drive Screw	SS, Commercial
24	Retainer Nut	Brass, B16
25	Retainer O-ring	BUNA-N 70 Duro, Commercial
26	Lift Cam O-ring	BUNA-N 70 Duro, Commercial
27	Cap	Bronze, B584 Alloy 84400
28	Lift Nut	SS, A479 316
29	Lift Washer	SS, A479 316
30	Stem	Brass, B16
31	Compression Screw	Brass, B16
32 ²	Gag Screw	Steel A108-1018/Zinc Plated
33 ³	Gag Screw Plug	SS 18-8
34 ³	Gag Screw Gasket	Teflon®

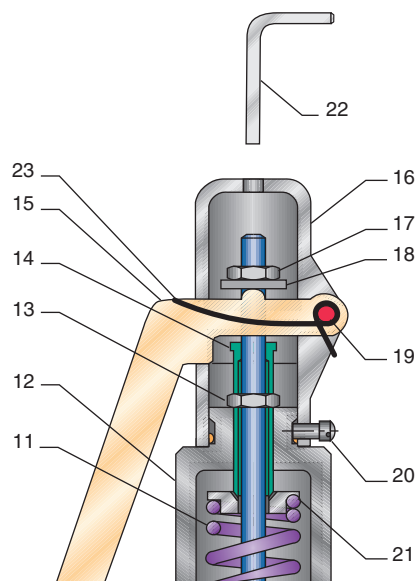

**Plain Lever
(shown with Gag and Vibration
Dampening Spring Options)**

Parts and Materials - Model 912 Plain Lever

No.	Part Name	Materials
11	Spring	Steel: A231/A231M w/coating ¹ SS: A313-302 SS: A313-316 Alloy steel: A681-H12
12	Bonnet	Brass, B16
13	Jam Nut	Brass, B16
14	Compression Screw	Brass, B16
15	Lever	Steel, A109 w/coating ¹
16	Cap	Aluminum, Anodized
17	Lift Nut	SS, A479-316
18	Lift Washer	SS, A479-316
19	Rivet	Steel, Commercial
20	Screw	SS, Commercial Gr. 18-8
21	Spring Step	Brass, B16
22 ²	Gag Screw	Steel A108-1018/Zinc Plated
23 ⁴	Vibration Dampening Spring	Phosphor BRZ 510

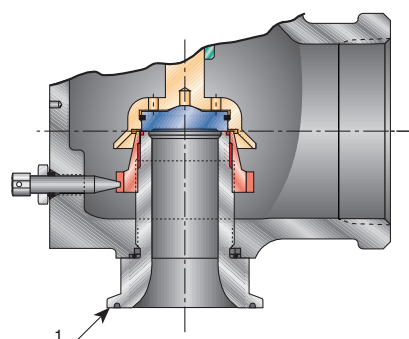

Tri-Clover (Inlet only)

Model 911 - Available with Tri-Clover Adapter Inlet

Model	Inlet	Orifice	Outlet
911 ZDE	1"	D	1"
911 ZEE	1"	E	1 1/4"
911 ZFG	1 1/2"	F	1 1/2"
911 ZGG	1 1/2"	G	2"
911 ZGH	2"	G	2"
911 ZHH	2"	H	2 1/2"
911 ZJJ	2 1/2"	J	3"

Notes

1. Corrosion preventative coating.
2. Gag screw ships with valve, not installed.
3. For threaded cap and packed lever gag option only.
4. Variation 05 only.

Kunkle Safety and Relief Products

Model 900

Models 912, 913, 918, 919 ASME Section VIII, Steam/Air/Gas/ Liquid, “UV” National Board Certified. Also available for Vacuum Service

Model Number Position	1	2	3	4	5	6	7	8	9	10	11	12	13	14	15	16
Example	9	1	2	B	J	H	M	0	1	—	K	E	0	3	0	0

Model

912, 913, 918, 919

Connection Model

B - Male x Female Threaded or NPT

Orifice

D, E, F, G, H, J

Inlet Size

C - 1/2" [15 mm] F - 1 1/4" [32 mm]
 D - 3/4" [18 mm] G - 1 1/2" [40 mm]
 E - 1" [25 mm] H - 2" [50 mm]

Seat/Seal Material

M - Metal-to-metal S - Silicone
 B - BUNA-N V - Viton®
 E - EPR N - Neoprene

Variation

Number provided only by manufacturer to cover specific feature or option.

- | | |
|---|---|
| 01 - Threaded cap | 14 - Plain lever - D orifice with 1" outlet |
| 02 - Threaded cap with gag | 15 - Plain Lever with Gag (D orifice with 1" outlet) |
| 03 - Plain lever | 16 - Plain Lever with Vibration Dampener (D orifice with 1" outlet) |
| 04 - Plain lever with gag | 17 - Packed lever - D orifice with 1" outlet |
| 05 - Plain lever with vibration dampener | 18 - Packed Lever with Gag (D orifice with 1" outlet) |
| 06 - Packed lever | 60 - BSP threads with threaded cap |
| 07 - Packed lever with gag | |
| 12 - Threaded cap (9*BDC with 1" outlet) | |
| 12 - Plain Lever with drain plug (913 BDDM only) | |
| 13 - Threaded cap (9*BDD with 1" outlet) | |
| 13 - Threaded Cap with Gag (9*BDC with 1" outlet) | |

Design Revision

Models	Orifice Size					
	D	E	F	G	H	J
912	—	—	—	—	—	—
913	—	—	—	—	—	—
918	B	B	—	—	—	—
919	B	B	—	—	—	—

Valve Service

- J - Liquid ASME Section VIII (Standard Cap/Packed Lever only)
- K - Air/Gas ASME Section VIII (Plain Lever/Packed Lever required for air)
- L - Steam ASME Section VIII (Plain Lever/Packed Lever required)
- M - Non-Code Liquid (Standard Cap/Packed Lever only)
- N - Non-Code Air Gas
- P - Non-Code Steam
- Q - Vacuum (Standard Cap/Packed Lever only)

Spring Material

- E - SST
- F - Alloy Steel (high temperature)

Set Pressure

3 psig [0.2 barg] (0003) to 900 psig [62 barg] (0900)
 Vacuum 6" HG [200 mbarg] (0006) to 29" HG [1000 mbarg] (0029)

Capacities - Models 910, 911, 912, 913, 916, 917, 918 and 919

**Non-code¹ and ASME Section VIII Air (U.S., SCFM) -
Flow Coefficient = 0.878**

Set Pressure (psig)	Orifice Area, in ²					
	D (0.1213)	E (0.2157)	F (0.3369)	G (0.553)	H (0.864)	J (1.415)
3	28	50	77	127	198	325
4	32	57	89	146	228	374
5	36	64	99	163	255	417
6	39	70	109	178	278	456
7	42	75	117	192	300	491
8	45	80	125	205	320	524
9	48	85	132	217	338	554
10	50	89	139	228	356	583
11	52	93	145	238	372	610
12	54	97	151	248	388	635
13	57	101	157	258	403	660
14	59	104	163	267	417	683
15	64	114	177	291	455	745
25	83	148	232	380	594	972
35	104	185	288	474	740	1212
45	125	223	348	571	893	1462
55	147	261	408	669	1046	1713
65	168	299	467	767	1199	1963
75	190	337	527	865	1352	2214
85	211	376	587	963	1505	2464
95	233	414	646	1061	1658	2715
100	243	433	676	1110	1734	2840
125	297	528	825	1355	2116	3466
150	351	624	974	1599	2499	4093
175	405	719	1124	1844	2881	4719
200	458	815	1273	2089	3264	5345
225	512	910	1422	2334	3646	5971
250	566	1006	1571	2578	4029	6598
275	619	1101	1720	2823	4411	7224
300	673	1197	1869	3068	4793	7850
325	727	1292	2018	3313	5176	8477
350	780	1388	2167	3558	5558	9103
375	834	1483	2316	3802	5941	9729
400	888	1579	2466	4047	6323	10355
425	941	1674	2615	4292	6705	10982
450	995	1769	2764	4537	7088	11608
475	1049	1865	2913	4781	7470	12234
500	1102	1960	3062	5026	7853	12861
600	1317	2342	3658	6005	—	—
700	1532	2724	4255	—	—	—
800	1747	3106	—	—	—	—
900	1957	3489	—	—	—	—
1000	2176	3870	—	—	—	—
1100	2391	—	—	—	—	—
1200	2606	—	—	—	—	—
1300	2820	—	—	—	—	—
1400	3035	—	—	—	—	—

Notes

1. No code stamp or "NB" on nameplate below 15 psig set.
2. See Specifications Table (pages 3 and 9) for Pressure and Temperature Limitations.

Capacities - Models 910, 911, 912, 913, 916, 917, 918 and 919

Non-code¹ and ASME Section VIII Air [Metric, Nm³/h] -
Flow Coefficient = 0.878

Set Pressure [barg]	Orifice Area, cm ²					
	D [0.7826]	E [1.3916]	F [2.1735]	G [3.5677]	H [5.574]	J [9.129]
0.2	45	80	126	206	322	528
0.5	71	126	196	323	504	825
1.0	98	175	273	448	700	1147
2.0	151	268	419	687	1074	1758
3.0	202	359	561	920	1438	2355
4.0	253	451	704	1155	1805	2956
5.0	305	542	847	1390	2172	3557
6.0	356	634	990	1625	2538	4157
7.0	408	725	1133	1860	2905	4758
8.0	459	817	1276	2094	3272	5359
9.0	511	908	1419	1329	3639	5960
10.0	562	1000	1562	2564	4006	6560
12.0	665	1183	1848	3033	4739	7762
14.0	768	1366	2134	3503	5473	8963
16.0	871	1549	2420	3972	6206	10165
18.0	974	1733	2706	4442	6940	11366
20.0	1077	1916	2992	4911	7673	12567
22.0	1180	2099	3278	5381	8407	13769
24.0	1283	2282	3564	5851	9141	14970
26.0	1386	2465	3850	6320	9874	16172
28.0	1489	2648	4136	6790	10608	17373
30.0	1592	2831	4422	7259	11341	18574
32.0	1695	3015	4708	7729	12075	19776
34.0	1798	3198	4994	8198	12808	20977
36.0	1901	3381	5280	8668	—	—
38.0	2004	3564	5567	9137	—	—
40.0	2107	3747	5853	9607	—	—
42.0	2210	3930	6139	—	—	—
44.0	2313	4113	6425	—	—	—
46.0	2416	4297	6711	—	—	—
48.0	2519	4480	6997	—	—	—
50.0	2622	4663	—	—	—	—
52.0	2725	4846	—	—	—	—
54.0	2828	5029	—	—	—	—
56.0	2931	5212	—	—	—	—
58.0	3034	5395	—	—	—	—
60.0	3137	5579	—	—	—	—
62.0	3240	5762	—	—	—	—
64.0	3345	5945	—	—	—	—
66.0	3448	6128	—	—	—	—
68.0	3551	6311	—	—	—	—
70.0	3654	—	—	—	—	—
72.0	3757	—	—	—	—	—
76.0	3963	—	—	—	—	—
80.0	4169	—	—	—	—	—
84.0	4375	—	—	—	—	—
88.0	4581	—	—	—	—	—
92.0	4788	—	—	—	—	—
96.0	4994	—	—	—	—	—

Notes

1. No code stamp or "NB" on nameplate below 1.1 barg set.
2. See Specifications Table (pages 3 and 9) for Pressure and Temperature Limitations.

Capacities - Models 910, 911, 912, 913, 916, 917, 918 and 919

Non-code¹ and ASME Section VIII Steam (U.S., lb/h) -
Flow Coefficient = 0.878

Set Pressure (psig)	Orifice Area, in ²					
	D (0.1213)	E (0.2157)	F (0.3369)	G (0.553)	H (0.864)	J (1.415)
3	87	155	242	398	621	1017
4	100	178	278	456	712	1167
5	111	197	308	506	791	1295
6	121	215	336	551	861	1410
7	130	231	360	591	924	1513
8	138	245	383	628	981	1607
9	145	258	403	662	1035	1694
10	152	271	423	694	1084	1776
11	159	282	441	724	1131	1852
12	165	293	458	752	1175	1924
13	171	304	474	778	1216	1992
14	176	313	489	803	1255	2056
15	179	319	498	818	1278	2092
25	234	416	650	1068	1668	2732
35	292	519	810	1330	2078	3404
45	352	626	978	1605	2508	4108
55	412	733	1146	1880	2938	4811
65	473	841	1313	2155	3368	5515
75	533	948	1481	2430	3797	6219
85	593	1055	1648	2706	4227	6923
95	654	1163	1816	2981	4657	7627
100	684	1216	1900	3118	4872	7979
125	835	1484	2319	3806	5946	9738
150	986	1753	2737	4493	7020	11498
175	1136	2021	3156	5181	8095	13257
200	1287	2289	3575	5869	9169	15017
225	1438	2557	3994	6556	10243	16776
250	1589	2826	4413	7244	11318	18536
275	1740	3094	4832	7932	12392	20295
300	1891	3362	5251	8619	13467	22055
325	2041	3630	5670	9307	14541	23814
350	2192	3898	6089	9994	15615	25574
375	2343	4167	6508	10682	16690	27333
400	2494	4435	6927	11370	17764	29093
425	2645	4703	7346	12057	18838	30852
450	2796	4971	7765	12745	19913	32612
475	2946	5239	8183	13433	20987	34371
500	3097	5508	8602	14120	22061	36131
550	3399	6044	9440	15496	—	—
600	3701	6581	10278	16871	—	—
650	4002	7117	11116	—	—	—
700	4304	7653	11954	—	—	—
750	4606	8190	—	—	—	—
800	4907	8726	—	—	—	—
850	5209	9263	—	—	—	—
900	5511	9799	—	—	—	—
950	5812	10336	—	—	—	—
1000	6114	10872	—	—	—	—
1100	6717	—	—	—	—	—
1200	7321	—	—	—	—	—
1300	7924	—	—	—	—	—
1400	8527	—	—	—	—	—

Notes

1. No code stamp or "NB" on nameplate below 15 psig set.
2. See Specifications Table (pages 3 and 9) for Pressure and Temperature Limitations.

Capacities - Models 910, 911, 912, 913, 916, 917, 918 and 919

Non-code¹ and ASME Section VIII Steam, [Metric, kg/h]-

Flow Coefficient = 0.878

Set Pressure [barg]	Orifice Area, cm ²					
	D [0.7826]	E [1.3916]	F [2.1735]	G [3.5677]	H [5.574]	J [9.129]
0.2	39	69	108	177	277	453
0.5	60	106	166	272	425	697
1.0	81	144	225	369	577	945
2.0	116	207	323	529	827	1355
3.0	156	277	432	709	1108	1815
4.0	195	347	542	890	1391	2278
5.0	235	418	653	1071	1673	2741
6.0	275	488	763	1252	1956	3204
7.0	314	559	873	1433	2239	3666
8.0	354	629	983	1614	2521	4129
9.0	394	700	1093	1795	2804	4592
10.0	433	771	1204	1976	3087	5055
12.0	513	912	1424	2337	3652	5981
14.0	592	1053	1644	2699	4217	6907
16.0	671	1194	1865	3061	4782	7832
18.0	751	1335	2085	3423	5348	8758
20.0	830	1476	2306	3785	5913	9684
22.0	910	1617	2526	4146	6478	10610
24.0	989	1758	2746	4508	7043	11535
26.0	1068	1900	2967	4870	7609	12461
28.0	1148	2041	3187	5232	8174	13387
30.0	1227	2182	3408	5594	8739	14313
32.0	1306	2323	3628	5955	9304	15238
34.0	1386	2464	3849	6317	9870	16164
36.0	1465	2605	4069	6679	—	—
38.0	1544	2746	4289	7041	—	—
40.0	1624	2887	4510	7403	—	—
42.0	1703	3029	4730	—	—	—
44.0	1783	3170	4951	—	—	—
46.0	1862	3311	5171	—	—	—
48.0	1941	3452	5391	—	—	—
50.0	2021	3593	—	—	—	—
52.0	2100	3734	—	—	—	—
54.0	2179	3875	—	—	—	—
56.0	2259	4016	—	—	—	—
58.0	2338	4157	—	—	—	—
60.0	2417	4299	—	—	—	—
62.0	2497	4440	—	—	—	—
64.0	2576	4581	—	—	—	—
66.0	2656	4722	—	—	—	—
68.0	2735	4863	—	—	—	—
70.0	2814	—	—	—	—	—
72.0	2894	—	—	—	—	—
76.0	3052	—	—	—	—	—
80.0	3211	—	—	—	—	—
84.0	3370	—	—	—	—	—
88.0	3529	—	—	—	—	—
92.0	3687	—	—	—	—	—
96.0	3846	—	—	—	—	—

Notes

1. No code stamp or "NB" on nameplate below 1.1 barg set.
2. See Specifications Table (pages 3 and 9) for Pressure and Temperature Limitations.

Capacities - Models 910, 911, 912, 913, 916, 917, 918 and 919

ASME VIII Liquid (U.S., GPM) - Flow Coefficient = 0.710

Set Pressure (psig)	Orifice Area, in ²					
	D (0.1213)	E (0.2157)	F (0.3369)	G (0.553)	H (0.864)	J (1.415)
15	14	25	39	63	99	162
25	17	31	48	79	123	202
35	20	36	56	93	145	237
45	23	41	64	105	164	269
55	26	45	71	116	181	297
65	28	49	77	126	197	323
75	30	53	83	136	212	347
85	32	56	88	144	225	369
95	34	60	93	153	238	390
100	34	61	95	156	244	400
125	38	68	107	175	273	448
150	42	75	117	192	299	490
175	45	81	126	207	323	530
200	49	86	135	221	346	566
225	52	92	143	235	367	601
250	54	97	151	247	387	633
275	57	101	158	259	405	664
300	60	106	165	271	423	694
325	62	110	172	282	441	722
350	64	114	178	293	457	749
375	67	118	185	303	473	775
400	69	122	191	313	489	801
425	71	126	197	323	504	825
450	73	129	202	332	519	849
475	75	133	208	341	533	873
500	77	136	213	350	547	895
550	81	143	224	367	—	—
600	84	150	234	383	—	—
650	88	156	—	—	—	—
700	91	161	—	—	—	—
750	94	167	—	—	—	—
800	97	173	—	—	—	—
850	100	178	—	—	—	—
900	103	183	—	—	—	—
950	106	—	—	—	—	—
1000	109	—	—	—	—	—
1050	111	—	—	—	—	—
1100	114	—	—	—	—	—
1150	116	—	—	—	—	—
1200	119	—	—	—	—	—
1250	121	—	—	—	—	—
1300	124	—	—	—	—	—
1350	126	—	—	—	—	—
1400	128	—	—	—	—	—

Notes

1. No code stamp or "NB" on nameplate below 15 psig set.
2. See Specifications Table (pages 3 and 9) for Pressure and Temperature Limitations.
3. Liquid conversion factors to determine liquid capacity at other than 10% accumulation, multiply by the following:
 1.022 = 15% accumulation
 1.045 = 20% accumulation
 1.066 = 25% accumulation (see page 20)

Capacities - Models 910, 911, 912, 913, 916, 917, 918 and 919

Non-code¹ and ASME Section VIII Liquid, [Metric m³/h] -
Flow Coefficient = 0.710

Set Pressure [barg]	Orifice Area, cm ²					
	D [0.783]	E [1.392]	F [2.174]	G [3.568]	H [5.574]	J [9.129]
1.0	3	6	9	14	22	36
2.0	4	7	12	19	30	49
3.0	5	9	14	23	37	60
4.0	6	11	16	27	42	69
5.0	7	12	18	30	47	77
6.0	7	13	20	33	52	85
7.0	8	14	22	36	56	92
8.0	8	15	23	38	60	98
9.0	9	16	25	41	63	104
10.0	9	17	26	43	67	110
12.0	10	18	29	47	73	120
14.0	11	20	31	51	79	130
16.0	12	21	33	54	85	139
18.0	13	22	35	57	90	147
20.0	13	24	37	61	95	155
22.0	14	25	39	63	99	162
24.0	15	26	40	66	104	170
26.0	15	27	42	69	108	177
28.0	16	28	44	72	112	183
30.0	16	29	45	74	116	190
32.0	17	30	47	77	120	196
34.0	17	31	48	79	123	202
36.0	18	32	49	81	—	—
38.0	18	33	51	83	—	—
40.0	19	33	52	86	—	—
42.0	19	34	—	—	—	—
44.0	20	35	—	—	—	—
46.0	20	36	—	—	—	—
48.0	21	37	—	—	—	—
50.0	21	37	—	—	—	—
52.0	21	38	—	—	—	—
54.0	22	39	—	—	—	—
56.0	22	40	—	—	—	—
58.0	23	40	—	—	—	—
60.0	23	41	—	—	—	—
62.0	23	42	—	—	—	—
64.0	25	—	—	—	—	—
66.0	26	—	—	—	—	—
68.0	26	—	—	—	—	—
70.0	26	—	—	—	—	—
72.0	27	—	—	—	—	—
76.0	28	—	—	—	—	—
80.0	28	—	—	—	—	—
84.0	29	—	—	—	—	—
88.0	30	—	—	—	—	—
92.0	30	—	—	—	—	—
96.0	31	—	—	—	—	—

Notes

1. No code stamp or "NB" on nameplate below 1.1 barg set.
2. See Specifications Table (pages 3 and 9) for Pressure and Temperature Limitations.

Capacities - Models 910, 911, 912, 913, 916, 917, 918 and 919

**Non-code Liquid - 25% Accumulation (U.S., GPM) -
Flow Coefficient = 0.710**

Set Pressure (psig)	Orifice Area, in ²					
	D (0.1213)	E (0.2157)	F (0.3369)	G (0.553)	H (0.864)	J (1.415)
3	6	11	18	29	45	74
4	7	13	20	33	52	85
5	8	15	23	37	58	95
6	9	16	25	41	64	105
7	10	17	27	44	69	113
8	10	18	29	47	74	121
9	11	20	30	50	78	128
10	12	21	32	53	82	135
11	12	22	34	55	86	142
12	13	23	35	58	90	148
13	13	23	37	60	94	154
14	14	24	38	62	98	160
15	14	25	39	65	101	165
25	18	33	51	83	130	213
35	22	38	60	99	154	253
45	25	44	68	112	175	286
55	27	48	75	124	193	317
65	29	52	82	134	210	344
75	32	56	88	144	226	370
85	34	60	94	154	240	394
95	36	63	99	163	254	416
100	37	65	102	167	261	427
125	41	73	114	186	291	477
150	45	80	124	204	319	523
175	48	86	134	221	345	565
200	52	92	144	236	369	604
225	55	98	152	250	391	640
250	58	103	161	264	412	675
275	61	108	169	277	432	708
300	63	113	176	289	451	739
325	66	117	183	301	470	769
350	68	122	190	312	488	799
375	71	126	197	323	505	827
400	73	130	203	334	521	854
425	75	134	210	344	537	880
450	78	138	216	354	553	905
475	80	142	221	364	568	930
500	82	145	227	373	583	954
600	90	159	249	409	—	—
700	97	172	—	—	—	—
800	103	184	—	—	—	—
900	110	195	—	—	—	—
1000	116	—	—	—	—	—
1100	121	—	—	—	—	—
1200	127	—	—	—	—	—
1300	132	—	—	—	—	—
1400	137	—	—	—	—	—

Note

1. See Specifications Table (pages 3 and 9) for Pressure and Temperature Limitations.

Capacities - Models 910, 911, 912, 913, 916, 917, 918 and 919

Non-code Liquid - 25% Accumulation, [Metric, m³/h]

Flow Coefficient = 0.710

Set Pressure [barg]	Orifice Area, cm ²					
	D [0.783]	E [1.392]	F [2.174]	G [3.568]	H [5.574]	J [9.129]
0.2	1	3	4	6	10	17
0.5	2	4	6	10	16	26
1.0	3	6	9	14	23	37
2.0	4	8	12	20	32	52
3.0	5	10	15	25	39	64
4.0	6	11	18	29	45	74
5.0	7	13	20	32	50	83
6.0	8	14	22	35	55	90
7.0	8	15	23	38	60	98
8.0	9	16	25	41	64	104
9.0	9	17	26	43	68	111
10.0	10	18	28	46	71	117
12.0	11	19	30	50	78	128
14.0	12	21	33	54	84	138
16.0	13	23	35	58	90	148
18.0	13	24	37	61	96	157
20.0	14	25	39	65	101	165
22.0	15	26	41	68	106	173
24.0	16	28	43	71	110	181
26.0	16	29	45	74	115	188
28.0	17	30	47	76	119	195
30.0	17	31	48	79	123	202
32.0	18	32	50	82	128	209
34.0	18	33	51	84	131	215
36.0	19	34	53	87	—	—
38.0	20	35	54	89	—	—
40.0	20	36	56	91	—	—
42.0	21	36	—	—	—	—
44.0	21	37	—	—	—	—
46.0	21	38	—	—	—	—
48.0	22	39	—	—	—	—
50.0	22	40	—	—	—	—
52.0	23	41	—	—	—	—
54.0	23	41	—	—	—	—
56.0	24	42	—	—	—	—
58.0	24	43	—	—	—	—
60.0	25	44	—	—	—	—
62.0	25	44	—	—	—	—
64.0	25	—	—	—	—	—
66.0	26	—	—	—	—	—
68.0	26	—	—	—	—	—
70.0	26	—	—	—	—	—
72.0	27	—	—	—	—	—
76.0	28	—	—	—	—	—
80.0	28	—	—	—	—	—
84.0	29	—	—	—	—	—
88.0	30	—	—	—	—	—
92.0	30	—	—	—	—	—
96.0	31	—	—	—	—	—

Note

1. See Specifications Table (pages 3 and 9) for Pressure and Temperature Limitations.

Capacities - Models 910, 911, 912, 913, 916, 917, 918 and 919

Non-code Vacuum Air - 10% Accumulation, (U.S., SCFM)

Flow Coefficient = 0.878

Set Inches Mercury	Orifice Area, in ²					
	D (0.1213)	E (0.2157)	F (0.3369)	G (0.553)	H (0.864)	J (1.415)
6	24	43	68	111	173	284
7	26	45	71	117	182	298
8	27	47	74	121	189	310
9	27	49	76	125	195	320
10	28	50	78	128	199	327
11	28	51	79	129	202	331
12	29	51	80	131	204	334
13	29	51	80	131	204	335
14	29	51	80	131	204	335
15	29	51	80	131	204	335
16	29	51	80	131	204	335
17	29	51	80	131	204	335
18	29	51	80	131	204	335
19	29	51	80	131	204	335
20	29	51	80	131	204	335
21	29	51	80	131	204	335
22	29	51	80	131	204	335
23	29	51	80	131	204	335
24	29	51	80	131	204	335
25	29	51	80	131	204	335
26	29	51	80	131	204	335
27	29	51	80	131	204	335
28	29	51	80	131	204	335
29	29	51	80	131	204	335

Kunkle Safety and Relief Products

Model 900

Capacities - Models 910, 911, 912, 913, 916, 917, 918 and 919

Non-code Vacuum Air - 10% Accumulation, [Metric, Nm³/h]

Flow Coefficient = 0.878

Set Pressure [mbarg]	Orifice Area, cm ²					
	D [0.7826]	E [1.3916]	F [2.1735]	G [3.5677]	H [5.574]	J [9.129]
200	40	71	111	182	285	466
225	42	74	115	189	296	485
250	43	76	119	196	306	501
275	44	78	123	201	314	515
300	45	80	125	206	321	526
325	46	82	127	209	327	535
350	46	83	129	212	331	542
375	47	83	130	214	334	548
400	47	84	131	215	336	551
425	47	84	132	216	337	553
450	47	84	132	216	337	552
475	47	84	132	216	338	553
500	47	84	132	216	338	553
525	47	84	132	216	338	553
550	47	84	132	216	338	553
575	47	84	132	216	338	553
600	47	84	132	216	338	553
625	47	84	132	216	338	553
650	47	84	132	216	338	553
675	47	84	132	216	338	553
700	47	84	132	216	338	553
725	47	84	132	216	338	553
750	47	84	132	216	338	553
775	47	84	132	216	338	553
800	47	84	132	216	338	553
845	47	84	132	216	338	553
850	47	84	132	216	338	553
875	47	84	132	216	338	553
900	47	84	132	216	338	553
925	47	84	132	216	338	553
950	47	84	132	216	338	553
975	47	84	132	216	338	553
1000	47	84	132	216	338	553