

Basic-Check®

The **DFT® Basic-Check Valve** is a versatile all-purpose, non-slam valve that provides reliable, low-maintenance service for a wide range of liquids, steam and gases at various pressure/temperature combinations. The valve consists of a guard cage, spring, valve disc, retaining ring and seat. It can be combined with pipe fittings such as reducing couplings, drain elbows, etc. to form a complete check valve unit ideally suited for a broad range of pipeline applications or incorporated into machinery for OEM applications. The metal-to-metal sealing area of the Basic-Check valve's disc and seat is precision-lapped, providing very tight shutoff of gas, steam and liquid. If bubble-tight shutoff is required, optional resilient soft seats are available.

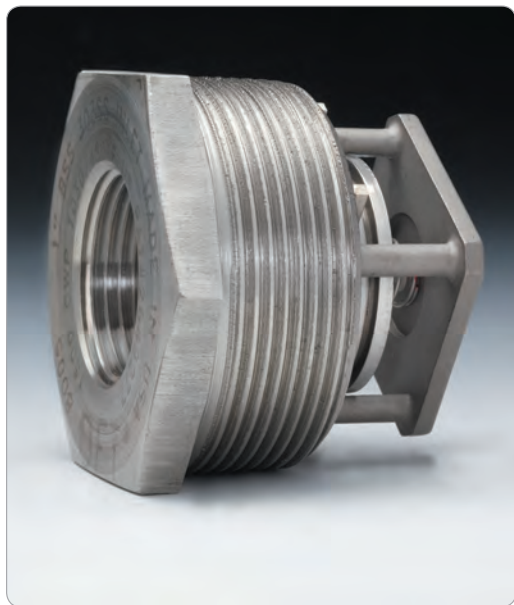

FEATURES:

- 1/4" to 2 1/2" Line size
- 450 to 6000 CWP
- Threaded ends
- Stainless steel construction
- Spring-assisted silent closing
- Horizontal or vertical installation
- Tight shutoff - lapped disc & seat
- Easy maintenance
- Versatile
- Options:
 - Inconel® X-750 spring
 - Soft seat

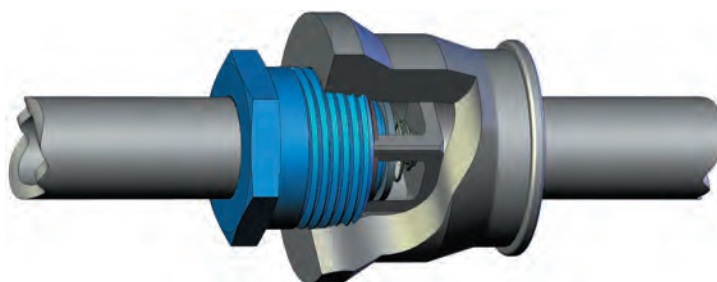

Can be used with reducing coupling

Basic-Check				Cracking Pressure	
A Line Size Inlet (FNPT)	B Outside Thread (MNPT)	Weight	Cv	PSI	Inches of Water
1/4	1	.38	5.8	.60 (1)	16.7
3/8	1	.38	5.8	.60 (1)	16.7
1/2	1	.38	5.8	.60 (1)	16.7
3/4	1 1/2	.88	13.2	.45	12.5
1	2	1.25	23.1	.38	10.5
1 1/4	2 1/2	2.25	36	.20	5.5
1 1/2	3	3.75	57.4	.14	3.9
2	4	7	90	.15	4.3
2 1/2	4	7	90	.15	4.3

*Cracking pressure shown for horizontal installation. Cracking pressure for vertical flow will be slightly different: upward flow, slightly higher; downward flow, slightly less.

Not recommended for use on discharge of reciprocating compressors.

Basic-Check®

COLD, NON-SHOCK PRESSURE RATING (PSIG) (2)

	1/4", 3/8", 1/2"	3/4"	1"	1 1/4"	1 1/2"	2"	2 1/2"
Basic-Check BSS, BSA, BSE	2500	2000	1500	850	700	450	450
High-Pressure BSSH6	6000	5500	3000	1100	900	450	450
High-Pressure BSSH7	6000	6000	6000	4000	2700	800	800

Sat. Steam Pressure (PSIG) Ref. (3)	Temperature (°F)	Adjusted Rating as Percent of Cold Rating
-3	200	86%
15	250	82%
52	300	78%
232	400	71%
407	450	69%
665	500	66%
1526	600	62%
3075	700	60%

All stainless steel construction is suitable for cryogenic service. For pressure rating at elevated temperatures for standard metal-seated valves, reduce rating per chart above.

Maximum valve temperature rating is limited by soft seat (if any) and spring materials. For ratings of soft seals using some other elastomers, consult DFT.

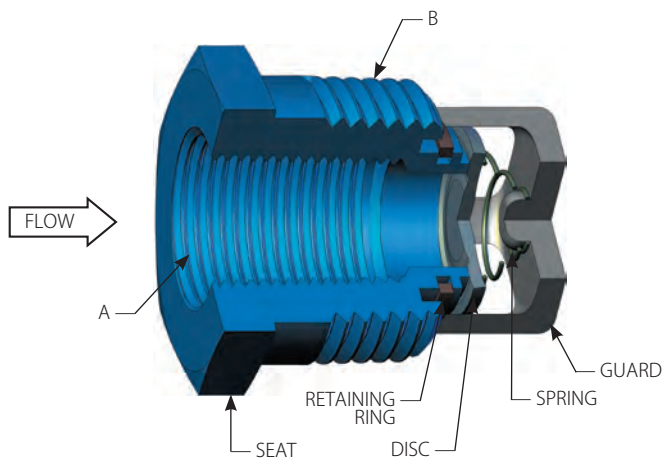

MATERIALS OF CONSTRUCTION

COMPONENT	Basic-Check BSS	Basic-Check BSA	Basic-Check BSE	High Pressure Basic-Check BSSH6	High Pressure Basic-Check BSSH7
Seat	303 SS	416 SS	303 SS	316 SS	316 SS
Disc	316 SS	316 SS	316 SS	316 SS	17-7 SS
Guard	CF8M (4)	CF8M	17-4 SS	CF8M	CF8M
Spring	316 SS	316 SS	Inconel® X-750	316 SS	316 SS
Retaining Ring	316 SS	316 SS	316 SS	316 SS	316 SS

- Notes:**
1. Light spring available: Cracking Pressure = .24 PSI (6.5 inches of water)
 2. Contingent on service ratings of matching pipe and fittings.
 3. Saturated steam pressure is given for reference only; pressure limit of valve is the adjusted rating at the given temperature.
 4. 1/4", 3/8" and 1/2" BSS units have a 303 SS guard.

All dimensions are in inches. Weights are in pounds. CP: Cracking Pressure (psig)