

# GLC®-Cast Iron

The **DFT® Model GLC Silent Check Valve** is a spring-assisted, center-guided, non-slam, flanged check valve that provides reliable, low-maintenance service for a wide range of fluids and pressure/ temperature combinations. The valve consists of a body, seat, spring, disc with stem and guide bushing. Some valves have O-ring or gasket body seals. The DFT GLC check valve has the advantage of minimum pressure loss with silent operation.



## FEATURES:

- "Short" Face-to-Face dimensions
- One-piece body
- Spring-assisted silent closing
- Center-guided
- Dual-guided stem
- Horizontal or vertical installation
- Easy maintenance
- Versatile
- ASME 125 & 250
  - 2 1/2" to 24" Line size (CI.125)
  - 2 1/2" to 8" Line size (CI.250)
  - Cast Iron Body(3)
  - Bronze or 316 SS trim
  - Ends:
    - FF Flanged
    - AWWA seat leakage
- Axial flow
- Nozzle style
  - Options:
    - Buna-N Soft Seat

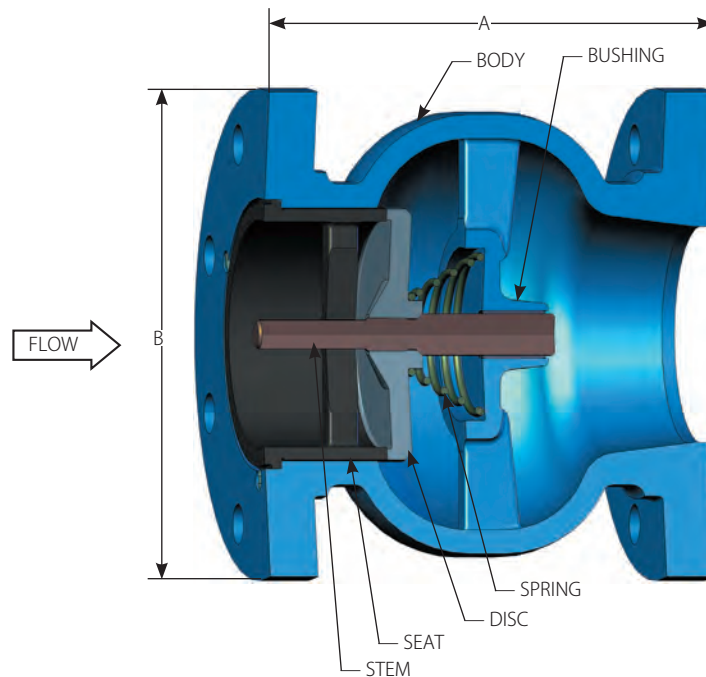

# GLC®-Cast Iron

	Class	125 CAST IRON FF	250 CAST IRON FF
2 1/2"	A	5.50	5.50
	B	7	7.50
	Weight	24	30
	Cv	110	110
3"	A	6	6
	B	7.50	8.25
	Weight	29	36
	Cv	155	155
4"	A	7.25	7.25
	B	9	10
	Weight	42	59
	Cv	278	278
5"	A	8.50	8.50
	B	10	11
	Weight	52	78
	Cv	435	435
6"	A	9.75	9.75
	B	11	12.50
	Weight	73	103
	Cv	625	625
8"	A	12.50	12.50
	B	13.50	15
	Weight	126	179
	Cv	1115	1115
10"	A	15.5	
	B	16	
	Weight	205	
	Cv	1770	

	Class	125 CAST IRON FF	250 CAST IRON FF
12"	A	14.25	
	B	19	
	Weight	306	
	Cv	2500	
14"	A	15.75	
	B	21	
	Weight	380	
	Cv	3400	
16"	A	17.63	
	B	23.50	
	Weight	501	
	Cv	4400	
18"	A	18.75	
	B	25	
	Weight	724	
	Cv	5600	
20"	A	20.63	
	B	27.50	
	Weight	890	
	Cv	6900	
24"	A	24	
	B	32	
	Weight	1220	
	Cv	10000	

## MATERIALS OF CONSTRUCTION (3)

COMPONENT	CAST IRON BODY/BRONZE TRIM	CAST IRON BODY/316 TRIM (1)
Body	A126 Class B Cast Iron	A126 Class B Cast Iron
Disc/Stem Assembly	B584 836 - Bronze	A351 CF8M
Seat (2)	B584 836 - Bronze	A351 CF8M
Spring	A313 T302 SS	A313 T302 SS
Bushing	B584 836 - Bronze	316 SS

## MAXIMUM OPERATING TEMPERATURES OF MATERIALS

	SOFT SEAT (2)
MATERIALS	BUNA-N
TEMP. °F	-70 to 250

## PRESSURE TEMPERATURE RATING FOR CAST IRON (PSIG)

	CLASS 125		CLASS 250	
Temp. (F°)	2 1/2" to 12"	14" +	2 1/2" to 12"	14" +
0-150°	200 psig	150 psig	400 psig	300 psig
200° Max (1)	190 psig	135 psig	370 psig	280 psig

- Notes:**
1. 316 stainless steel trim recommended for temperatures from 180°F to 200°F.
  2. Buna-N soft seat available for bubble-tight shutoff.
  3. Not recommended for steam service.

All dimensions are in inches. Weights are in pounds.