

The **DFT[®] Model GLC Silent Check Valve** is a spring-assisted, center-guided, non-slam, flanged check valve that provides reliable, low-maintenance service for a wide range of fluids and pressure/ temperature combinations. The valve consists of a body, seat, spring, disc with stem and guide bushing. Some valves have O-ring or gasket body seals. The DFT GLC check valve has the advantage of minimum pressure loss with silent operation.

FEATURES:

- "Short" Face-to-Face dimensions
- API 6FD Fire Test
 - ASME 150 and 300
 - 2" to 24"
- Standard body materials:
 - A216 Grade WCB carbon steel
 - A351 CF8M stainless steel
- Optional body materials:
 - Alloy 20
 - Duplex SS
 - Hastelloy[®]
 - Monel[®]
- One-piece body
- Spring-assisted silent closing, non-slam
- Center-guided
- Dual-guided stem
- Horizontal or vertical installation
- Protected spring
- Easy maintenance
- Versatile
- ASME 150 To 2500 (See chart)
 - 1" to 24" Line size
 - 316 SS trim
 - RF Flanged ends
 - MSS-SP61 seat leakage
- Axial flow
- Nozzle style
- OPTIONS:
 - Inconel[®] X-750 Spring
 - Soft seat
 - Custom sizing low flow
 - Severe service trim
 - Stellite trim (600°F+)
 - RTJ Ends (3)
 - NACE (Page 39)

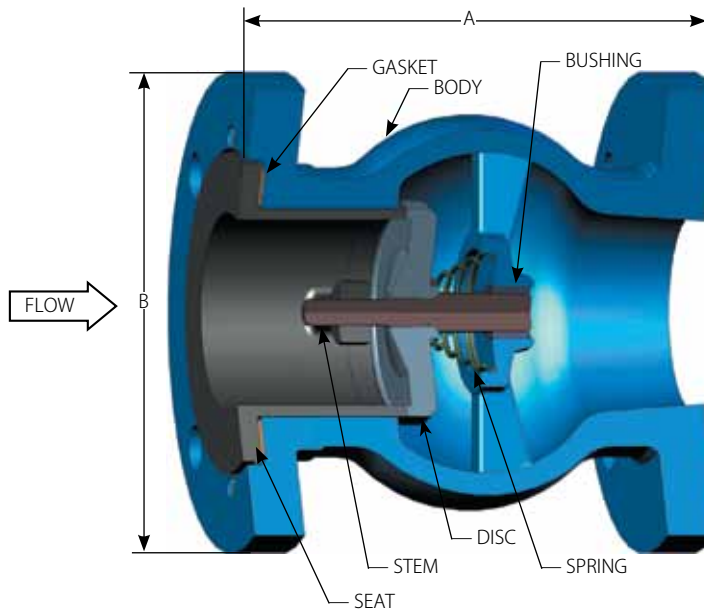

MATERIALS OF CONSTRUCTION

COMPONENT	CARBON STEEL BODY	STAINLESS STEEL BODY
Body	A216 WCB	A351 CF8M
Disc/Stem Assembly	A351 CF8M/A479 316	A351 CF8M/A479 316
Seat	A351 CF8M	A351 CF8M
Spring (1)	A313 316	A313 316
Bushing	A479 316	A479 316
Gasket (2)	CFG/316 SS/Graphite	

Consult pages 40 and 41 for Pressure/Temperature ratings and soft seat materials.

Class	150 RF	300 RF	600 RF	900 RF	1500 RF	2500 RF
1"	A	4.50	4.75	5.25	*	*
	B	4.25	4.88	4.88		
	Weight	7	9	11		
	Cv	17	19	17		
	CP	0.85	0.85	0.85		
1 1/2"	A	5.75	6	6.63	7.38	7.38
	B	5	6.13	6.13	7	7
	Weight	13	17	19	30	30
	Cv	35	35	35	26	26
	CP	0.29	0.29	0.29	0.64	0.40
2"	A	6.25	6.50	7.25	8.25	8.25
	B	6	6.50	6.50	8.50	8.50
	Weight	17	23	25	56	56
	Cv	63	63	63	46	46
	CP	0.29	0.29	0.29	0.32	0.32
2 1/2"	A	7.00	7.25	*	9	9
	B	7.00	7.50		9.63	9.63
	Weight	31	41		78	78
	Cv	100	100		81	81
	CP	0.18	0.18		0.11	0.11
3"	A	7.50	7.88	8.63	9.13	9.88
	B	7.50	8.25	8.25	9.50	10.50
	Weight	33	46	57	87	110
	Cv	148	148	125	114	114
	CP	0.20	0.20	0.41	0.26	0.52
4"	A	8.50	9.13	10.13	10.63	11.38
	B	9	10	10.75	11.50	12.25
	Weight	55	71	115	127	164
	Cv	260	267	237	217	192
	CP	0.49	0.48	0.54	0.49	0.67
5"	A	9.50	10.38	*	*	*
	B	10	11			
	Weight	72	89			
	Cv	415	415			
	CP	0.28	0.28			
6"	A	10	11	12.38	13	15.13
	B	11	12.50	14	15	15.50
	Weight	93	139	175	264	405
	Cv	620	620	549	549	441
	CP	0.41	0.39	0.46	0.46	0.42

Class	150 RF	300 RF	600 RF	900 RF	1500 RF	2500 RF
8"	A	12	13	14.63	15.25	17.50
	B	13.5	15	16.50	18.50	19
	Weight	172	232	332	396	670
	Cv	1030	933	933	851	742
	CP	0.41	0.45	0.45	0.50	0.55
10"	A	14	15.38	17.13	17.63	23
	B	16	17.50	20	21.50	23
	Weight	266	335	450	539	1281
	Cv	1630	1704	1620	1499	1231
	CP	0.55	0.52	0.35	0.64	0.53
12"	A	18	19.50	21.25	*	44.50
	B	19	20.50	22		26.50
	Weight	387	550	840		2550
	Cv	2370	2370	2272		1689
	CP	0.47	0.49	0.41		0.60
14"	A	21	23	24	*	*
	B	21	23	23.75		*
	Weight	456	724	975		
	Cv	3500	2781	2775		
	CP	0.52	0.43	0.43		
16"	A	22.50	24	26	*	*
	B	23.50	25.5	27		*
	Weight	700	898	1093		
	Cv	5100	5100	5100		
	CP	0.51	0.59	0.59		
18"	A	24	24	*	*	*
	B	25	30.88			*
	Weight	753	1255			
	Cv	6400	6400			
	CP	0.59	0.59			
20"	A	24	24	35	*	*
	B	27.50	30.50	37		*
	Weight	1292	1357	2636		
	Cv	7700	7700	9828		
	CP	0.49	0.55	0.59		
24"	A	28	28	*	*	*
	B	32	36			*
	Weight	1571	2420			
	Cv	11100	10510			
	CP	0.44	0.46			

- Notes:**
- Inconel® X-750 spring is available.
 - CFG corrugated flexible graphite (Class 150 & 300), 316 SS/Graphite Spiral Wound (Class 600 & up)
 - Contact DFT for availability
- * Consult DFT for valve availability.

All dimensions are in inches. Weights are in pounds. CP: Cracking Pressure (psig)