

Vacuum Breaker

DFT® Vacuum Breakers provide effective protection against collapse of pressure vessels, tanks and rolls. They prevent condensate “back-up” when equipment is shut down or inlet steam is reduced by modulating control valves. In piping systems, DFT Vacuum Breakers are used to break siphons, prevent pipe collapse during transient pressure drops, and to provide addition of air on the downstream side of check valves to dampen water hammer.

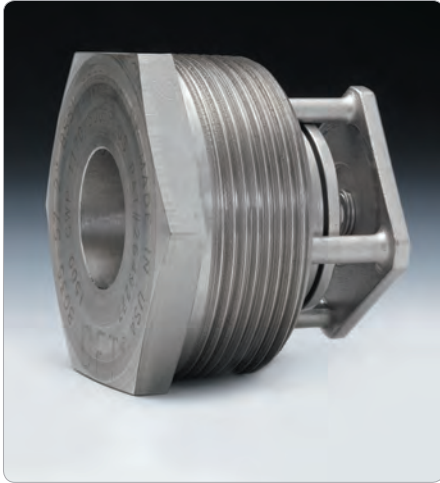

FEATURES:

- 1" to 4" size (Outside diameter)
- 450 to 6000 CWP
- Threaded O.D. (MNPT)
- Unthreaded inlet bore
- Stainless steel construction
- Spring-assisted silent closing
- Horizontal or vertical installation
- Tight shutoff - lapped disc & seat
- Easy maintenance
- Versatile
- Options:
 - Inconel® X-750 spring
 - Soft seat

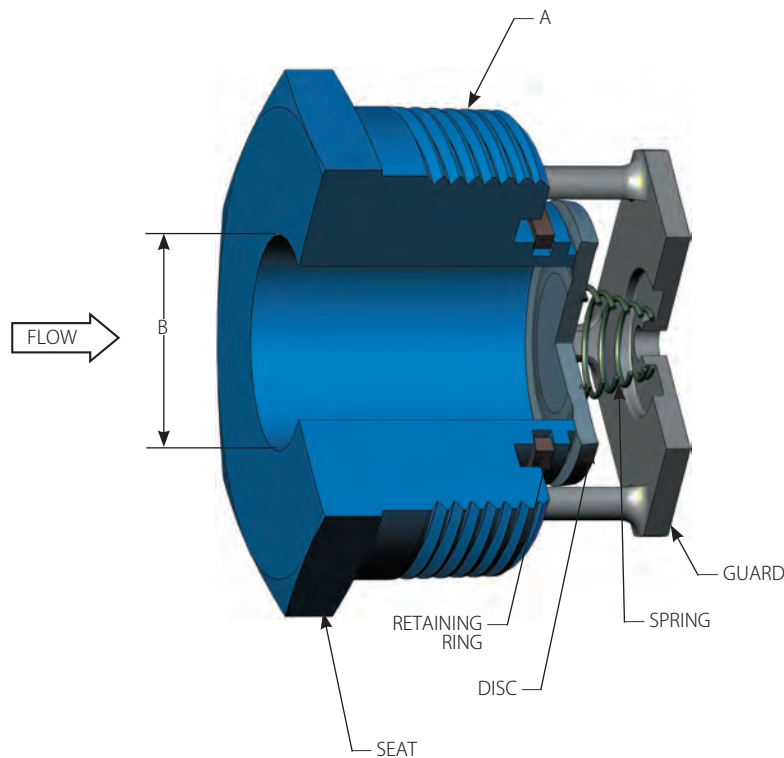

Vacuum Breaker

Vacuum Breaker				Cracking Pressure	
A Nominal Size (MNPT)	B Unthreaded Inlet Bore	Weight	Cv	PSI	Inches of Water
1	.56	.38	5.8	.60 (1)	16.7
1 1/2	.88	.88	13.2	.45	12.5
2	1.09	1.25	23.1	.38	10.5
2 1/2	1.50	2.25	36	.20	5.5
3	1.72	3.75	57.4	.14	3.9
4	2.22	7.00	90	.15	4.3

*Cracking pressure for vertical flow will be slightly different: upward flow, slightly higher; downward flow, slightly less.

COLD, NON-SHOCK PRESSURE RATING (PSIG) (2)

	1"	1 1/2"	2"	2 1/2"	3"	4"
Vacuum Breaker BSSV	2500	2000	1500	850	700	450
Vacuum Breaker BSSV6	6000	5500	3000	1100	900	450

MATERIALS OF CONSTRUCTION

COMPONENT	Vacuum Breaker BSSV	High Pressure Vacuum Breaker BSSV6
Seat	303 SS	316 SS
Disc	316 SS	316 SS
Guard	CF8M (3)	CF8M
Spring	316 SS	316 SS
Retaining Ring	316 SS	316 SS

Sat. Steam Pressure (PSIG) Ref. (4)	Temperature (°F)	Adjusted Rating as Percent of Cold Rating
-3	200	86%
15	250	82%
52	300	78%
232	400	71%
407	450	69%
665	500	66%
1526	600	62%
3075	700	60%

All stainless steel construction is suitable for cryogenic service. For pressure rating at elevated temperatures for standard metal-seated valves, reduce above rating per chart above.

Maximum valve temperature rating is limited by soft seal (if any) and spring materials in chart above.

- Notes:**
1. Light spring available: Cracking Pressure = .24 PSI (6.5 inches of water)
 2. Contingent on service ratings of matching pipe and fittings.
 3. 1" units have a 303 SS guard.
 4. Saturated steam pressure is given for reference only; pressure limit of valve is the adjusted rating at the given temperature.

All dimensions are in inches. Weights are in pounds. CP: Cracking Pressure (psig)