

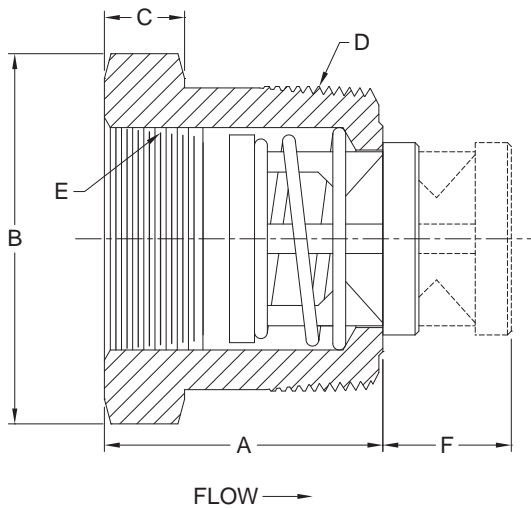

The **Bushing (BU)** valve is a check valve with a standard bushing housing. The valve is adaptable to many types of service applications. It has very little restriction and produces a low pressure drop. It can be used quite effectively in systems where flow and pressure drop are critical by the use of a reducer coupling. The Bushing valve also makes an excellent **vacuum breaker**. The high flow rate insures maximum effectiveness for vacuum breaker service. By reversing the direction of flow it can also be used as a low-pressure **relief valve**.

The bushing thread sizes are designated by two sets of numbers; the first being the male thread, the second the female thread.



Nom. Pipe Size	Size Code	A	Hex ^① Size B	C	D	E	F ^②	Orifice Dia.
1/2 x 3/8	D	1.30	7/8	1/4	1/2 NPT	3/8 NPT	0.53	0.348
3/4 x 1/2	F	1.30	1-1/8	1/4	3/4 NPT	1/2 NPT	0.61	0.464
1 x 3/4	H	1.83	1-3/8	1/2	1 NPT	3/4 NPT	0.78	0.593
1-1/4 x 1	I	1.83	1-3/4	1/2	1-1/4 NPT	1 NPT	0.85	0.890
1-1/2 x 1-1/4	J	2.17	2	5/8	1-1/2 NPT	1-1/4 NPT	1.01	1.135
2 x 1-1/2	K	2.17	2-1/2	5/8	2 NPT	1-1/2 NPT	1.19	1.385
2-1/2 x 2	L	2.53	3	5/8	2-1/2 NPT	2 NPT	1.43	1.555
3 x 2-1/2	M	3.09	3-1/2	1	3 NPT	2-1/2 NPT	1.59	2.025

^① May be larger and/or round.

^② Maximum nominal dimension for a fully open valve with no spring.

Body Material ^③	Availability	Non-Shock Pressure-Temperature Rating
316 Stainless Steel (SS)	Standard	3000 PSIG @ 100°F (1500 PSIG for o-ring seats)
Carbon Steel (CS)		
Brass (BR)		
Alloy 20 (A2)	Semi-standard	
Hastelloy [®] C (HC)		
Monel [®] (MO)		
Hastelloy [®] B (HB)	Contact the factory for these or other materials	
Titanium (TI)		

Bushing
For Water at 72°F

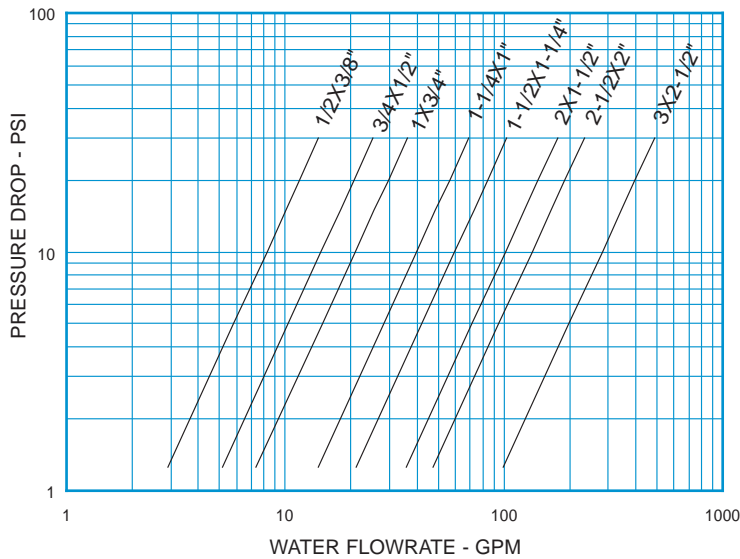

Note: All flow curves and Cv values presume the valves are fully open with 1/2 PSI cracking pressure springs. Consult the factory for more information.

STYLE BU C _v VALUES & VALVE WEIGHTS		
C _v	SIZE	ALL MATL
2.6	1/2 x 3/8	1.7 oz.
4.6	3/4 x 1/2	2.9 oz.
6.6	1 x 3/4	6.4 oz.
12.6	1-1/4 x 1	10.8 oz.
18.8	1-1/2 x 1-1/4	13.8 oz.
32.0	2 x 1-1/2	1.6 lb.
42.5	2-1/2 x 2	2.3 lb.
89.0	3 x 2-1/2	5.4 lb.

See page 48 for Flow Formulae
Valve weights are approximate.

**HOW TO ORDER
CHECK-ALL STYLE BU**

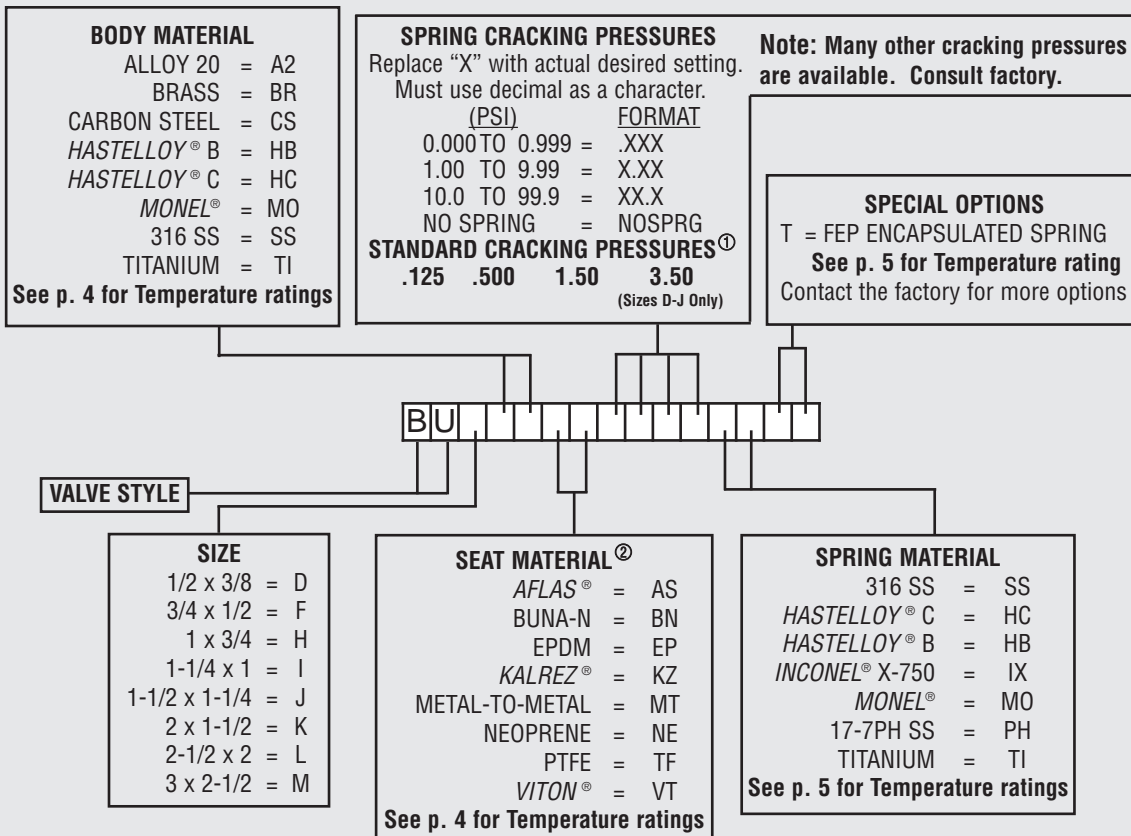

Listed above are the most common material selections. Please contact the factory for additional options.

① .500 PSI is the only standard cracking pressure for spring materials other than Stainless Steel. Cracking pressure tolerance is +/- 15%. .125 PSI springs are not recommended for installations with flow vertical down.

② Seat materials other than metal-to-metal have a maximum pressure rating of 1500 PSI. PTFE seats are not resilient. See page 49 for allowable leakage rates.