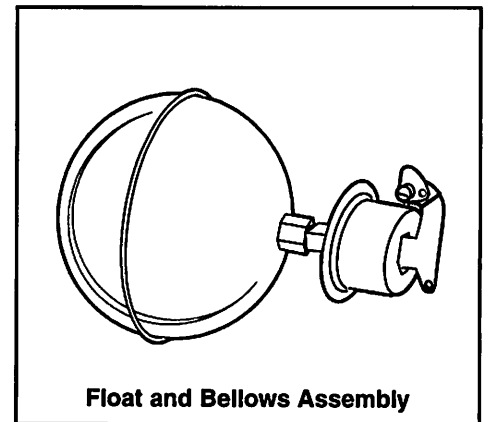









## Replacement Float and Large Bellows Assembly

For Combination Mechanical  
Water Feeder/Low Water Cut-Off

Series	Float	Bellows Assembly
51/51-2	310437	310439
51-S/51-S-2	310437	310439
53/53-2	310438	310441



### **WARNING**

	<ul style="list-style-type: none"><li>• Before using this product read and understand instructions.</li><li>• Save these instructions for future reference.</li><li>• All work must be performed by qualified personnel trained in the proper application, installation, and maintenance of plumbing, steam, and electrical equipment and/or systems in accordance with all applicable codes and ordinances.</li><li>• To prevent electrical shock, turn off the electrical power before making electrical connections.</li><li>• To prevent serious burns, the boiler must be cooled to 80°F (27°C) and the pressure must be 0 psi (0 bar) before servicing.</li></ul> <p>Failure to follow this warning could cause property damage, personal injury or death.</p>
	
	
	
	

## STEP 1 - Preparation

### **WARNING**

Release pressure to 0 psi (0 bar) and let boiler cool to 80°F (27°C). Drain water level down below the float chamber.  
Turn off all electrical power to the boiler.  
Failure to follow this warning could cause property damage, personal injury or death.

**Determine which series water feeder/low water cut-off you have from figures 1 through 4 on page 3.**

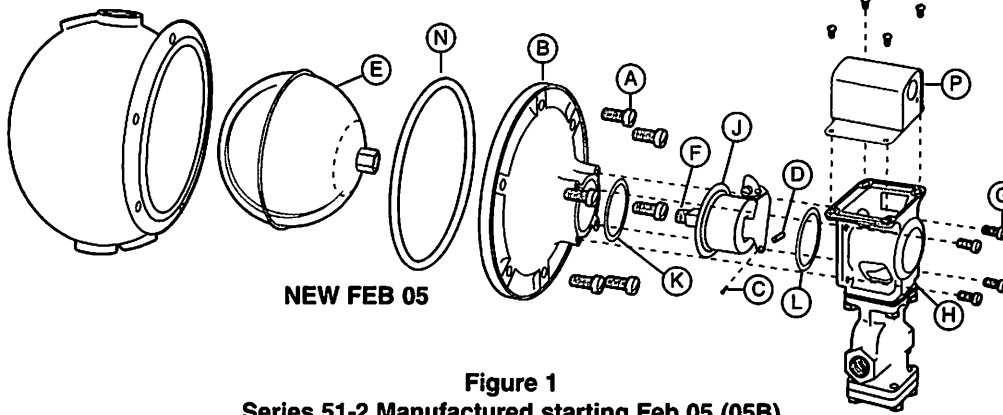
- **Units manufactured before May 99 (99E) and starting February 05 (05B) use figure 1 or**  
**NOTE:** Units manufactured prior to May 99 (99 E) and those manufactured starting February 05 (05B) have a similar design but use a different thread size. They are not interchangeable.
- **Units manufactured after May 99 (99E) through January 05 (05A) use figure 2 or 4**

- If necessary, remove the four (4) screws that hold the No. 2 (P) switch and remove switch.
- Remove piping from the valve assembly (H) only.
- Remove the six (6) bolts (A) that hold the head onto the float chamber and remove the head flange (B).
- Remove cotter pin (C) and pin (D) from the float arm and valve linkage.
- Units manufactured before May 99 (99E) and starting February 05 (05B)**  
Use a wrench on both float and float arm to unscrew float (E) from float arm (F).  
**Units manufactured after May 99 (99E) through January 05 (05A)**  
Unscrew locking nut (M) and unscrew float (E) from float arm (F).
- Remove four (4) screws or hex screws (G). Carefully slide die casting and valve assembly (H) over switch cam and set aside. Remove bellows cup (J) from head casting (B).

## STEP 2 - Installation for Models 51, 51S, and 53

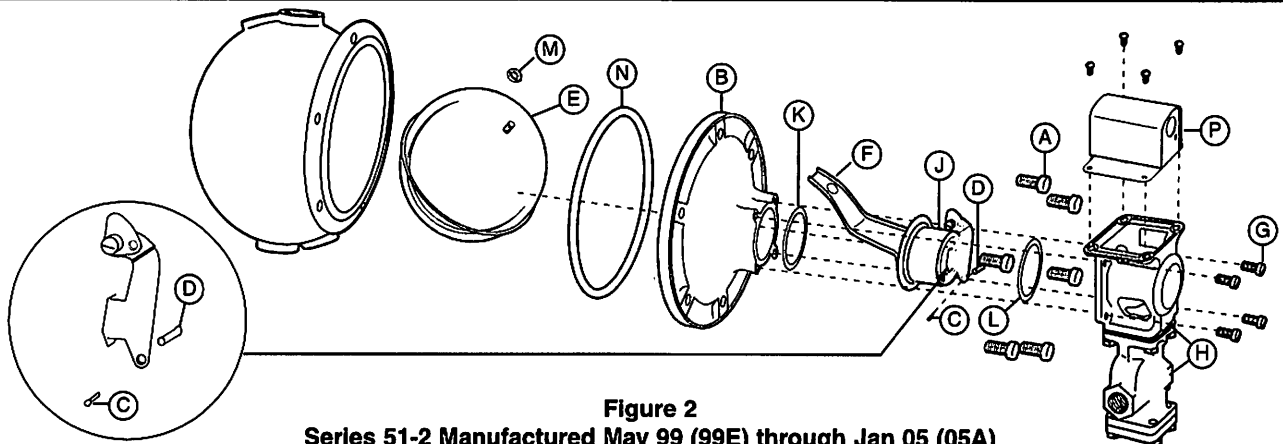
**NOTE:** New replacement bellows cup (J) will require one time float (E) replacement. See figure 1 or 3. Although similar, the floats and bellows assemblies from before May 1999 do not fit new assemblies.

- Clean gasket surfaces on head casting (B) and die casting and valve assembly (H).
- Put gasket (K) in the recess on the head casting (B). Place the other gasket (L) over the bellow cup (J).
- Install the bellow cup (J) into the head casting (B). Make sure the tab on the bellows cup fits into the notch on the head casting.
- Carefully slip die casting-and-valve assembly (H) over switch cam and attach it to head casting (B), using the four (4) screws (G).
- Screw float (E) into float arm (F) of bellow cup (J). Make sure float is screwed on all the way.
- Install head casting (B) onto float chamber using new gasket (N) and six (6) bolts (A). Tighten in a star pattern to 35 - 40 ft./lbs. (35-40 N•m).
- Reinstall the piping and the No. 2 switch (P) if necessary.

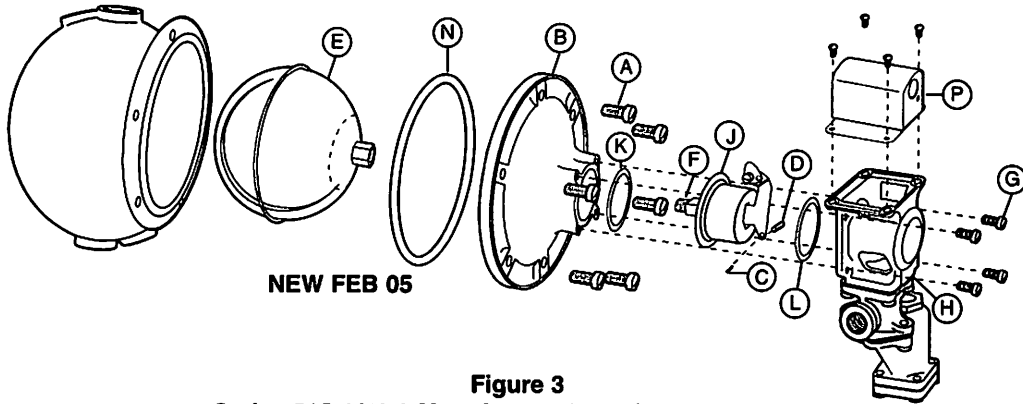


NEW FEB 05

**Figure 1**  
Series 51-2 Manufactured starting Feb 05 (05B)

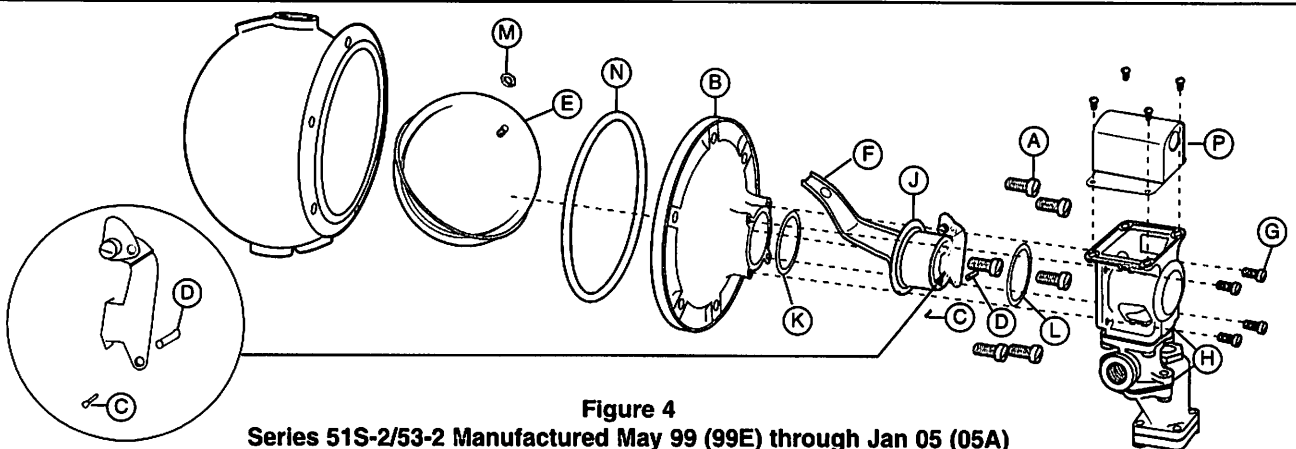


**Figure 2**  
Series 51-2 Manufactured May 99 (99E) through Jan 05 (05A)



NEW FEB 05

**Figure 3**  
Series 51S-2/53-2 Manufactured starting Feb 05 (05B)

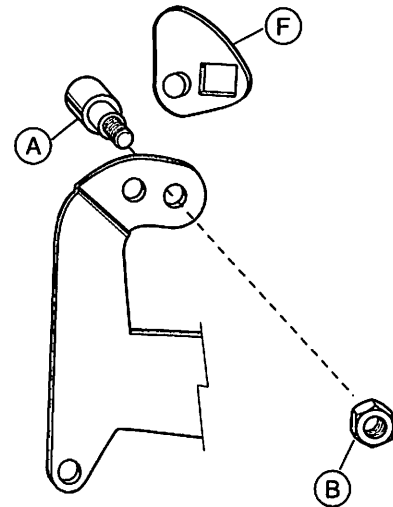


**Figure 4**  
Series 51S-2/53-2 Manufactured May 99 (99E) through Jan 05 (05A)

### STEP 3 - Setting the Cam

Refer to the proper cam assembly figure below

- a. Establish boiler water level at 5/8" to 1 1/8" (16-29mm) below the low water cut-off casting line, or where control previously turned burner off
- b. Using a flathead screwdriver, turn eccentric screw (A) until cam (F) is set in lowest possible position.
- c. Slowly, turn eccentric screw (A) raising the cam (F) until the switch activates, opening the common and normally closed contacts. Hold eccentric screw (A) in position and tighten nut (B) on the opposite end.



### STEP 4 - Testing

- a. Check to see that the burner turns on and off at the proper water level, by raising and lowering the water level in the boiler.
- b. Make sure there is additional downward travel remaining in the float arm after the burner goes off.
- c. Repeat test several times.