

LOCKWOOD®

TYPE VCS CONDENSATE RETURN SYSTEMS

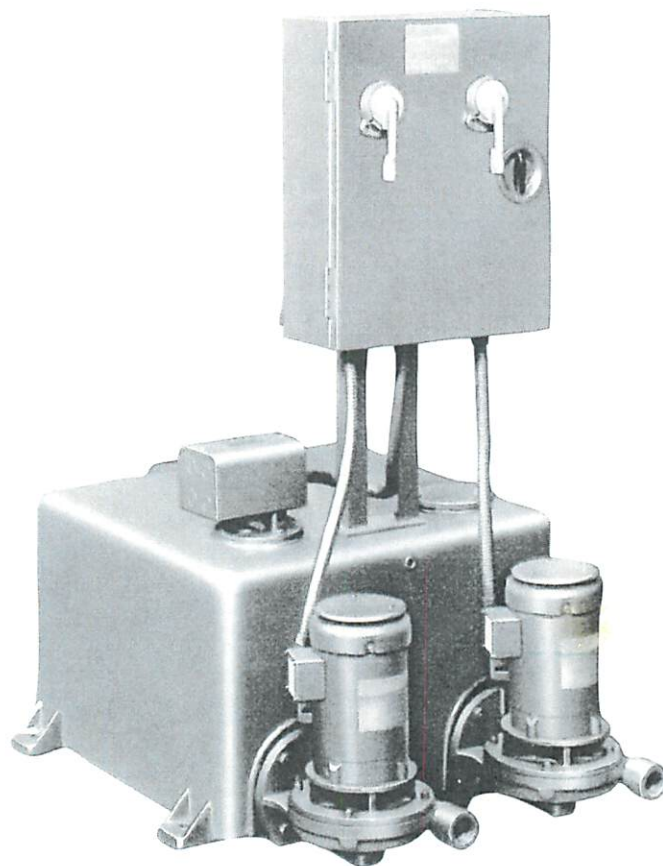

ILLUSTRATED WITH OPTIONAL EQUIPMENT

Bulletin
CR - VCS
3 - 96

TYPE VCS CONDENSATE RETURN SYSTEMS

Lockwood VCS pumping systems are available in simplex, duplex, triplex or quadruplex configurations from 1,000 to 100,000 sq. ft. EDR capacities. Discharge pressures from 10–40 psi are available on units equipped with 1750 rpm motors; 15-75 psi on 3500 rpm units. Standard selections use 1750 rpm motors only on 10 psi applications.

RECEIVERS

Cast iron, rectangular receivers are available with 15 to 110 gallon capacities.

Heavy duty, welded, rust resistant, copper bearing steel receivers are available in rectangular or cylindrical configurations with capacities ranging from 21 to 1,000 gallons. Consult your local representative for custom engineered receivers and rust resistant linings.

LOCKWOOD CENTRIFUGAL PUMPS

Four centrifugal models are available in a large selection of sizes to meet your specific application requirements: VC, VJ, VE and VA.

The pumps are bolted directly to the receiver to provide a compact, efficient design. Their close-coupled, centrifugal design with bronze enclosed type impeller assures smooth, efficient water passage. A mechanical seal, rated to a maximum temperature of 220°F, is vented to the receiver to assure adequate lubrication at all times.

All standard selections are rated for condensate temperatures up to 200°F. Consult factory for higher temperature applications, as some pumps are available that have low NPSH capability. These pumps have advanced impeller and volute design that can provide true 2' NPSH capacity without using additional impellers and parts required by other manufacturers.

Designed for long-life, low maintenance and reliable service, the pumps are easily serviceable if necessary. Parts subject to normal wear are readily accessible. Impeller and seal can be serviced without disturbing piping or electrical connections.

All pumps are close-coupled to heavy duty, ball bearing electric motors. Fractional horsepower single phase motors have built-in thermal overload protection.

To help you determine the appropriate pump type for your application, specifications for each of the four types are described in the next paragraphs. Refer to selection table for additional pumping system performance data.

- **VJ PUMPS**
1/2 thru 2 hp
3500 rpm — discharge pressures are 15, 20, 30, 40 or 50 psi
Motor types available: Open drip proof (ODP) only
Single phase, 115/230 V, 60 Hz
Three phase, 208 or 230/460 V, 60 Hz
- **VC PUMPS**
1/3 thru 15 hp
1725 rpm — discharge pressures are 10, 15 or 20 psi
3500 rpm — discharge pressures are 30 to 75 psi
Motor types available: Open drip proof (ODP)
Totally enclosed fan cooled (TEFC)
Explosion proof
Single phase, 115/230 V, 60 Hz
Three phase, 208 or 230/460 V, 60 Hz
- **VE PUMPS***
3/4 thru 2 hp
1750 rpm — discharge pressures are 20, 25 or 30 psi
Motor types available: Open drip proof (ODP)
Totally enclosed fan cooled (TEFC)
Explosion proof
Single phase, 115/230 V, 60 Hz
Three phase, 200 V, 60 Hz
Three phase, 230/460 V, 60 Hz
- **VA PUMPS***
3, 5 or 7½ hp
1750 rpm — discharge pressures are 30 or 40 psi
Motor types available: Open drip proof (ODP)
Totally enclosed fan cooled (TEFC)
Explosion proof
Three phase, 200 V, 60 Hz
Three phase, 230/460 V, 60 Hz

*Contact factory for recommended selections.

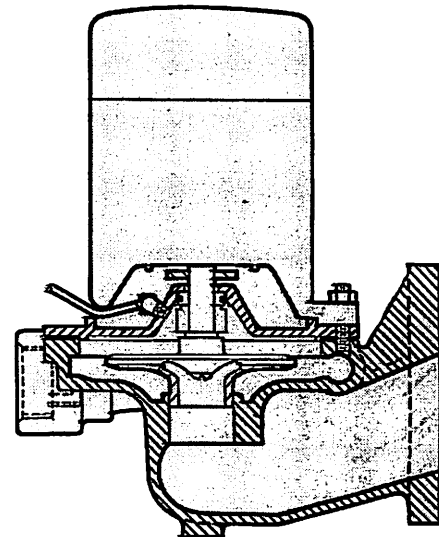

TYPICAL PUMP CROSS-SECTION

SELECTION CHART LOCKWOOD TYPE VCS CONDENSATE RETURN SYSTEMS

All selections listed below at 10 psi are 1750 rpm — all others, 3500 rpm except 801½ and 1001½.

Max. Sq. Ft. E.D.R.	Receiver Size	Pump Cap. G.P.M.	Disch. Press. at Pump	Pump Type	Pump Size	Motor H.P.	Return Pipe Size	Disch. Pipe Size
1,000	15 or 21	1½	10	VCS	-11	1/3	2" CAST IRON	1¼"
			15		-11½	1/2		
			20		-12	1/2		
			30		-13	1/2		
			40	VJS	-14	1		
			50		-15	1½		
			60		-16	2		
75		-17½	3					
2,000	15 or 21	3	10	VCS	-21	1/3	2" CAST IRON	1¼"
			15		-21½	1/2		
			20		-22	1/2		
			30	VJS	-23	1/2		
			40		-24	1		
			50		-25	1½		
			60		-26	2		
75	VCS	-27½	3					
4,000	15 or 21	6	10	VCS	-41	1/3	2" CAST IRON	1¼"
			15		-41½	1/2		
			20		-42	1/2		
			30	VJS	-43	1/2		
			40		-44	1		
			50		-45	1½		
			60		-46	2		
75	VCS	-47½	3					
6,000	15 or 21	9	10	VCS	-61	1/3	2" CAST IRON	1¼"
			15		-61½	1/2		
			20		-62	1/2		
			30	VJS	-63	1/2		
			40		-64	1		
			50		-65	2		
			60		-66	2		
75	VCS	-67½	3					
8,000	15 or 21	12	10	VCS	-81	1/3	2" CAST IRON	1¼"
			15		-81½	1/2		
			20		-82	1/2		
			30	VJS	-83	1/2		
			40		-84	1		
			50		-85	2		
			60		-86	2		
75	VCS	-87½	3					
10,000	15 or 21	15	10	VCS	-101	1/3	2" CAST IRON	1¼"
			15		-101½	1/2		
			20		-102	1/2		
			30	VJS	-103	3/4		
			40		-104	1		
			50		-105	2		
			60		-106	2		
75	VCS	-107½	3					
15,000	21	22½	10	VCS	-151	1/3	2" CAST IRON	1½"
			15		-151½	1/2		
			20		-152	1/2		
			30	VJS	-153	3/4		
			40		-154	1		
			50		-155	2		
			60		-156	3		
75	VCS	-157½	3					
20,000	45	30	10	VCS	-201	1/3	2½" CAST IRON	1½"
			15		-201½	1/2		
			20	VJS	-202	3/4		
			30		-203	1		

Max. Sq. Ft. E.D.R.	Receiver Size	Pump Cap. G.P.M.	Disch. Press. at Pump	Pump Type	Pump Size	Motor H.P.	Return Pipe Size	Disch. Pipe Size
20,000	45	30	40	VJS	-204	1½	2½" CAST IRON	1½"
			50		-205	2		
			60	VCS	-206	3		
			75		-207½	5		
25,000	45	37½	10	VCS	-251	1/2	2½" CAST IRON	1½"
			15		-251½	1/2		
			20	VJS	-252	3/4		
			30		-253	1		
			40		-254	1½		
			50	VCS	-255	3		
			60		-256	3		
			75		-257½	5		
30,000	45	45	10	VCS	-301	1/2	2½" CAST IRON	1½"
			15		-301½	1		
			20	VJS	-302	1		
			30		-303	1½		
			40		-304	2		
			50	VCS	-305	3		
			60		-306	3		
			75		-307½	7½		
40,000	65	60	10	VCS	-401	3/4	3" CAST IRON	1½"
			15		-401½	1½		
			20	VJS	-402	1½		
			30		-403	1½		
			40		-404	3		
			50	VCS	-405	5		
			60		-406	5		
			75		-407½	7½		
50,000	65	75	10	VCS	-501	1	3" CAST IRON	2"
			15		-501½	1½		
			20	VJS	-502	1½		
			30		-503	2		
			40		-504	3		
			50	VCS	-505	5		
			60		-506	5		
			75		-507½	7½		
65,000	110	97½	10	VCS	-651	1½	4" CAST IRON	2"
			15		-651½	2		
			20	VJS	-652	2		
			30		-653	3		
			40	VCS	-654	5		
			50		-655	5		
			60		-656	7½		
80,000	110	120	10	VCS	-801	1½	5" CAST IRON	2"
			15		-801½	2		
			20		-802	3		
			30		-803	5		
			40		-804	5		
			50		-805	7½		
			60		-806	7½		
100,000	110	150	10	VCS	-1001	1½	5" CAST IRON	2"
			15		-1001½	2		
			20		-1002	5		
			30		-1003	5		
			40		-1004	7½		
			50		-1005	7½		
			60		-1006	10		

Duplex Unit Shown with Steel Receiver

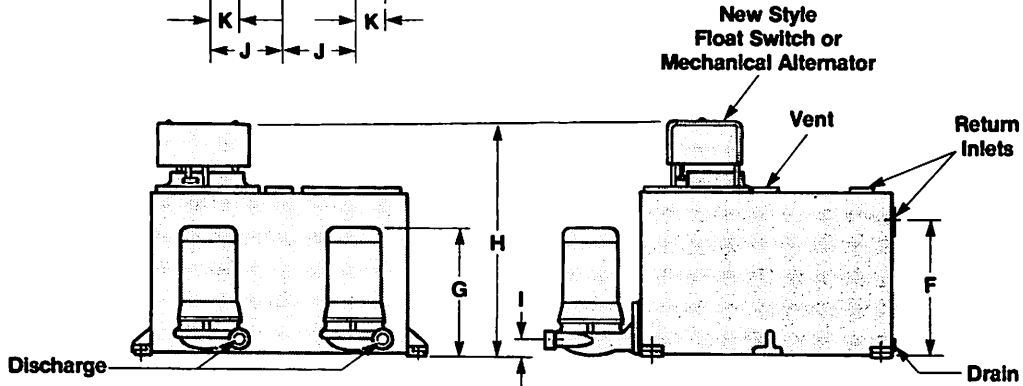
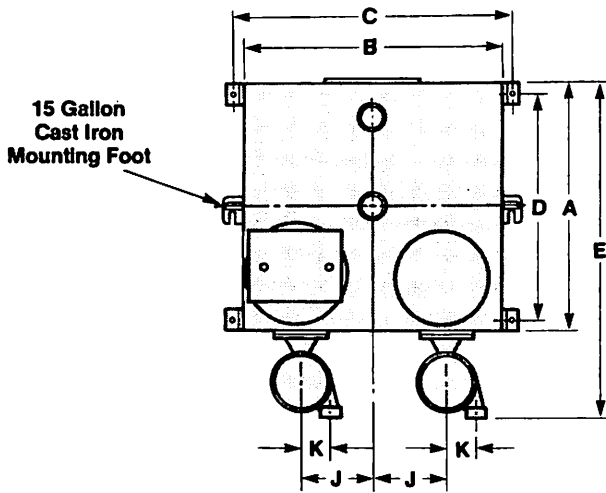

DIMENSIONAL DATA — VC, VJ and VE Pumps with Cast Iron or Steel Rectangular Receivers

CAP. SQ. FT. E.D.R.	RECEIVER CAP. GALS	APPROXIMATE DIMENSIONS										
		A	B	C	D	E	F	G	H	I	J	K
CAST IRON MODELS VCS, VJS, VES												
1,000 to 4,000	15	15	17½	19½	∅	28	13	16 to 19	22	4	5¼	4
1,000 to 15,000	21	21	22¾	26	14¾	34	10¼ or Top	16 to 21	19½	4	6	4
20,000 to 30,000	45	26	26¾	28¾	20	39	15	16 to 21	23¾	4	7½	4
40,000 to 50,000	65	28½	28½	30¾	22¾	41½	19½	16 to 21	29	4¾	7½	4
65,000 to 100,000	110	30	42	36¼	32	43	19½	18 to 28	28½	4	7½	4
STEEL RECEIVER MODELS VCSS, VJSS, VESS												
1,000 to 15,000	21	18	24	26⅞	16⅞	31	9 or Top	16 to 19	19	4	6	4
20,000 to 30,000	45	24	24	26⅞	22⅞	37	15½ or Top	16 to 21	25	4	6	4
40,000 to 50,000	65	24	24	26⅞	22⅞	37	21½ or Top	16 to 21	30½	4	6	4
65,000 to 100,000	110	30	42½	45	25	43	17 or Top	18 to 28	27	4	11	4

The specifications contained in this bulletin were effective at the time of publishing. Lockwood Products, Inc. reserves the right to discontinue products at any time or to change specifications or design without incurring any obligation.

LOCKWOOD PRODUCTS, INC.

4450 Commerce Drive, S.W.
 P.O. Box 43961
 Atlanta, Georgia 30336
 Local (404) 505-2520 • WATS (800) 365-1500 • FAX (404) 505-2555