

LOCKWOOD®

TYPE VMX CONDENSATE RETURN SYSTEMS



VMX CONDENSATE PUMPS

CONDENSATE PUMPING UNIT SPECIFICATIONS

Capacity: To 12,000 sq.ft. EDR or 18 gpm

Discharge Pressures: 20, 30 and 40 psi

Condensate Temperatures: To 200°F

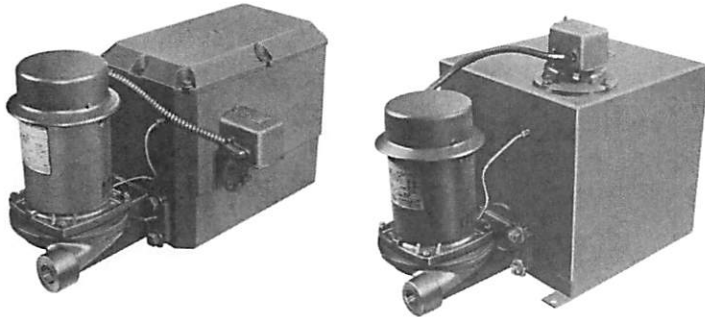

Condensate pumps are used in low pressure steam heating systems to collect and quickly return condensate to the boiler or boiler feed unit. Pumping action is controlled by an integral float switch on simplex (one pump) units or mechanical alternator on duplex (two pump) units. Unlike boiler feed units, which are controlled by a boiler mounted control and equipped with a make-up valve mechanism, condensate pumps usually do not directly supply boiler make-up water.

SIMPLEX UNITS

Simplex units are equipped with vapor tight, heavy duty float switch control with stainless steel float. Easily field adjustable, to provide proper pump control and operation.

Receivers are available in your choice of cast iron or welded steel construction.

Long lasting, close grained cast iron receivers; available in 6, 15, 21 and 45 gallon sizes.

Welded, copper bearing steel receivers; available in 10, 20 and 45 gallon capacities.

Simplex units may be ordered mounted on duplex reservoirs to provide an opportunity for conversion to a duplex unit at a later time.

DUPLEX UNITS

Duplex units offer some additional distinct advantages over simplex units. They are used where an unusually heavy amount of condensate must be returned or where it is desirable to have a stand-by pump available. Equipped with a float operated, automatic mechanical alternator, they provide several benefits.

System overload protection — The second pump is activated if the rate of condensate return exceeds the limits of the first pump.

Extra long service life — Each of the two pumps is activated automatically on alternating pumping cycles so the work load is evenly distributed between the two pumps.

Back-up system protection — A second pump is automatically actuated if the first one fails to start. With optional isolation valves, maintenance or repairs can be made on either pump without shutting down the other one or interrupting system operation.

Duplex unit receivers are available in your choice of cast iron or welded steel construction.

Long lasting, close grained cast iron receivers; available in 15, 21 and 45 gallon sizes.

Welded, copper bearing steel receivers; available in 20 and 45 gallon sizes.

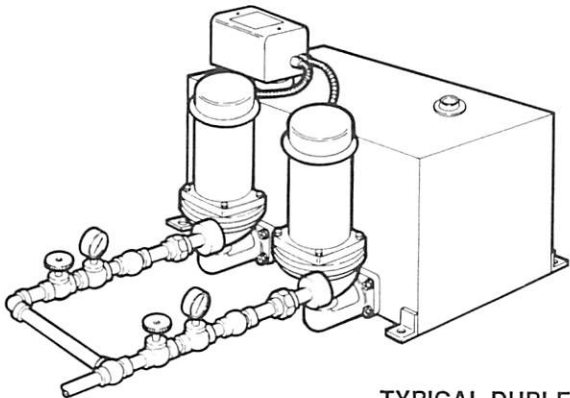
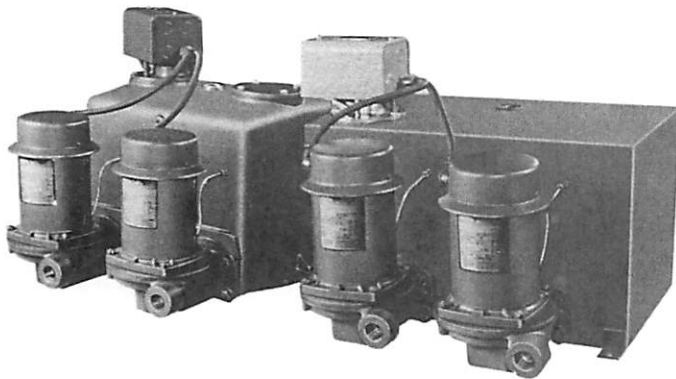

TYPICAL DUPLEX PUMP INSTALLATION

FEATURES

- Close coupled, centrifugal design with bronze enclosed type impeller (improved NORYL on 20 psi units).
- Impeller is designed to assure smooth, efficient water passage.
- Designed for long-life.
- Mechanical seal withstands temperatures to 220°F, recirculated to pump suction to assure adequate lubrication at all times.

- Heavy duty, drip proof, 3450 rpm, 60 Hz motor; designed for continuous duty with pre-lubricated, shielded ball bearings and stainless steel shaft. Your choice of single phase 115/230 volt with built-in overload protection or three phase 220/440 volt. T.E.F.C. available upon request.
- Low maintenance, easily serviceable design; any part subject to normal wear is readily accessible. Impeller and seal can be serviced without disturbing system piping or electric connections.
- Universal type 4-bolt flange mounting.

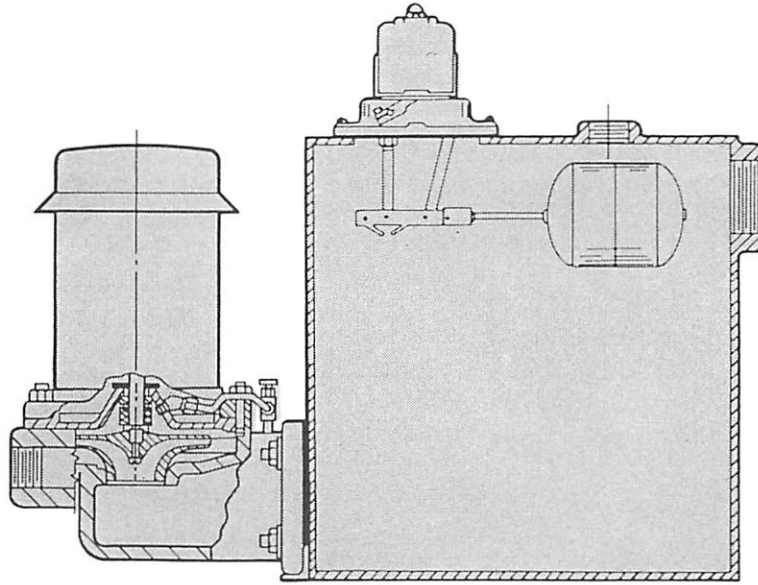

TYPICAL VMX CROSS-SECTION

SELECTION DATA

PHASE & VOLTAGE	DISC. PRESS	HP	5,000 EDR			8,000 EDR		12,000 EDR	
			SIMPLEX 6 GAL C.I.	SIMPLEX 15 GAL C.I.	DUPLEX 15 GAL C.I.	SIMPLEX 10 GAL STEEL	DUPLEX 20 GAL STEEL	SIMPLEX 20 GAL STEEL	DUPLEX 20 GAL STEEL
Single 115/230 V	20	1/3	VMX 52S	VMX 102S	VMX 102D	VMX 82S	VMX 82D	VMX 122S	VMX 122D
	30	1/2	VMX 53S	VMX 103S	VMX 103D	VMX 83S	VMX 83D	VMX 123S	VMX 123D
	40	3/4	VMX 54S	VMX 104S	VMX 104D	VMX 84S	VMX 84D	VMX 124S	VMX 124D
Three 230/460 V	20	1/3	VMX 52S	VMX 102S	VMX 102D	VMX 82S	VMX 82D	VMX 122S	VMX 122D
	30	1/2	VMX 53S	VMX 103S	VMX 103D	VMX 83S	VMX 83D	VMX 123S	VMX 123D
	40	3/4	VMX 54S	VMX 104S	VMX 104D	VMX 64S	VMX 84D	VMX 124S	VMX 124D

OPTIONAL SUCTION ISOLATION VALVE

An optional suction isolation valve is available for simplex and duplex units. When installed between the pump and receiver on simplex units, it allows the pump motor assembly to be removed without draining the receiver. On duplex units, it permits one pump to be removed while the other one continues to operate without interrupting system operation.

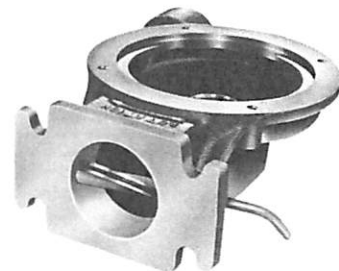

CAST IRON RECEIVERS

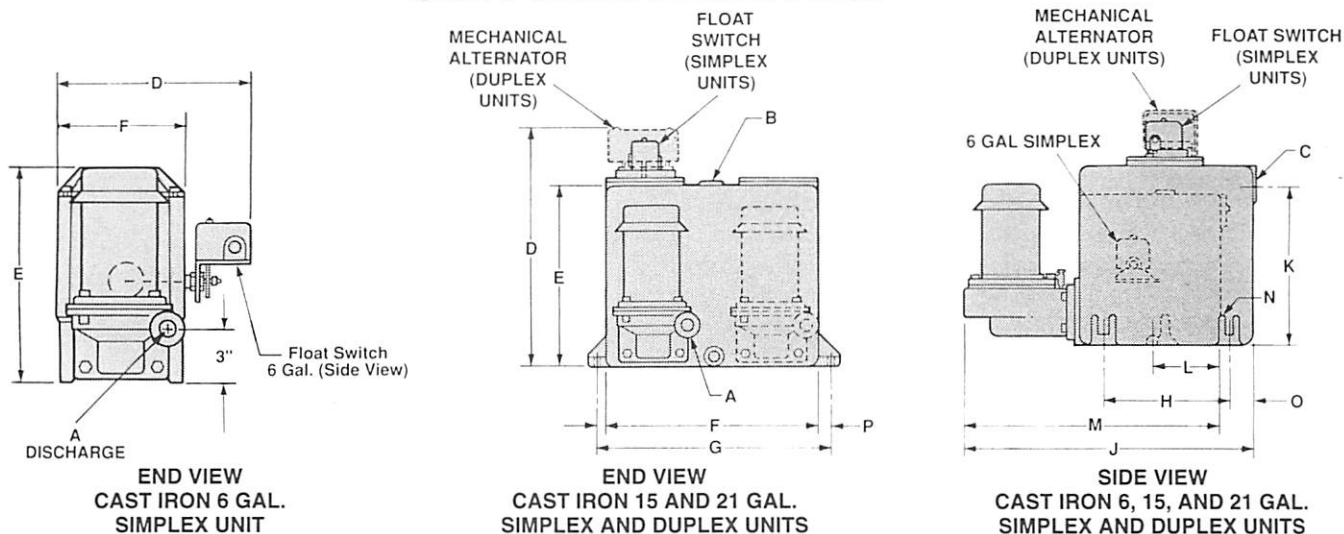

DIMENSIONAL DATA (IN INCHES)

RECEIVER SIZE	A	B	C	D	E	F	G	H	J	K	L	M	N	O	P
Simplex 6 Gal.	1	1	2	14.5	14.5	9.5				9.9		27	1.2		
Simplex 15 Gal.	1	1	2	21	15.6	17.6	19.8		26.5	13.3	9.3				1
Duplex 15 Gal.	1	1	2	21.5	15.6	17.6	19.8		26.5	13.3	9.3				1
Simplex 21 Gal.	1	1.2	2	18	12.4	22.7	27.7	18	31.8	10.2				1.5	1.5
Duplex 21 Gal.	1	1.2	2	18.4	12.4	22.7	27.7	18	31.8	10.2				1.5	1.5
Simplex 45 Gal.	1	1.5	2.5	19.3	17.3	26.7	28.7	20	36.7	15				2.8	1
Duplex 45 Gal.	1	1.5	2.5	21.3	17.3	26.7	28.7	20	36.7	15				2.8	1

STEEL RECEIVERS

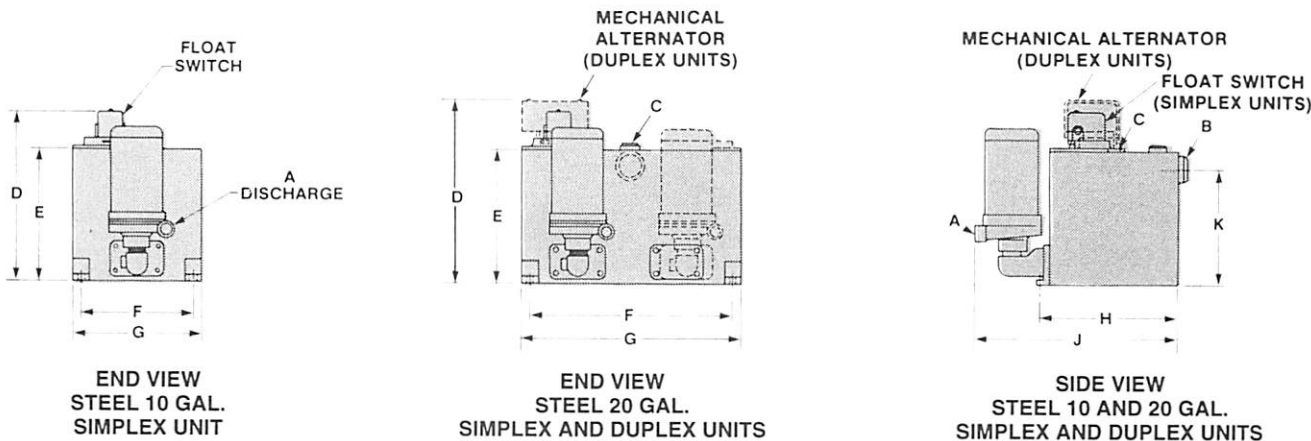

DIMENSIONAL DATA (IN INCHES)

RECEIVER SIZE	A	B	C	D	E	F	G	H	J	K
Simplex 10 Gal.	1	2	1	18.2	14.2	12.5	14.3	15.2	25.2	12.7
Simplex 20 Gal.	1	2	1	18.2	14.2	22.5	24.3	15.2	25.2	12.7
Duplex 20 Gal.	1	2	1	19.7	14.2	22.5	24.3	15.2	25.2	12.7
Simplex 45 Gal.	1	3	2	22.4	18.4	24.4	26.4	24.4	35.4	15.7
Duplex 45 Gal.	1	3	2	24.4	18.4	24.4	26.4	24.4	35.4	15.7

The specifications contained in this bulletin were effective at the time of publishing. Lockwood Products, Inc. reserves the right to discontinue products at any time or to change specifications or design without incurring any obligation.

LOCKWOOD PRODUCTS, INC.

4450 Commerce Drive, S.W.

P.O. Box 43961

Atlanta, Georgia 30336

Local (404) 505-2520 • WATS (800) 365-1500 • FAX (404) 505-2555