

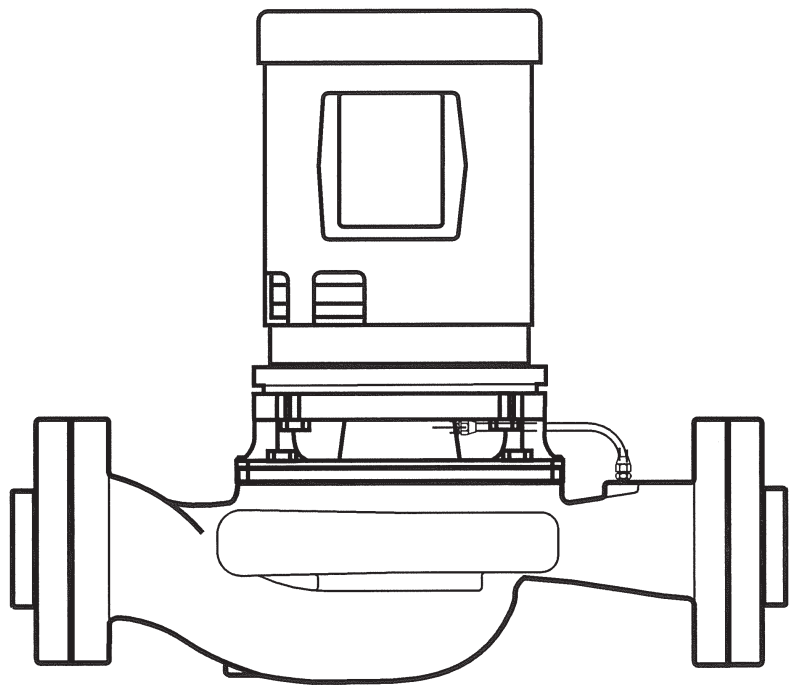

**AURORA<sup>®</sup>**



# 326A SERIES COMMERCIAL IN LINE MOUNTED CENTRIFUGAL PUMP

## REPAIR PARTS INDEX

NOTE! Read and understand the pump and motor instructions before attempting to install, disassemble or repair the pump.

**326A SERIES**  
**MODEL 326A**  
**PIECE NUMBERS**

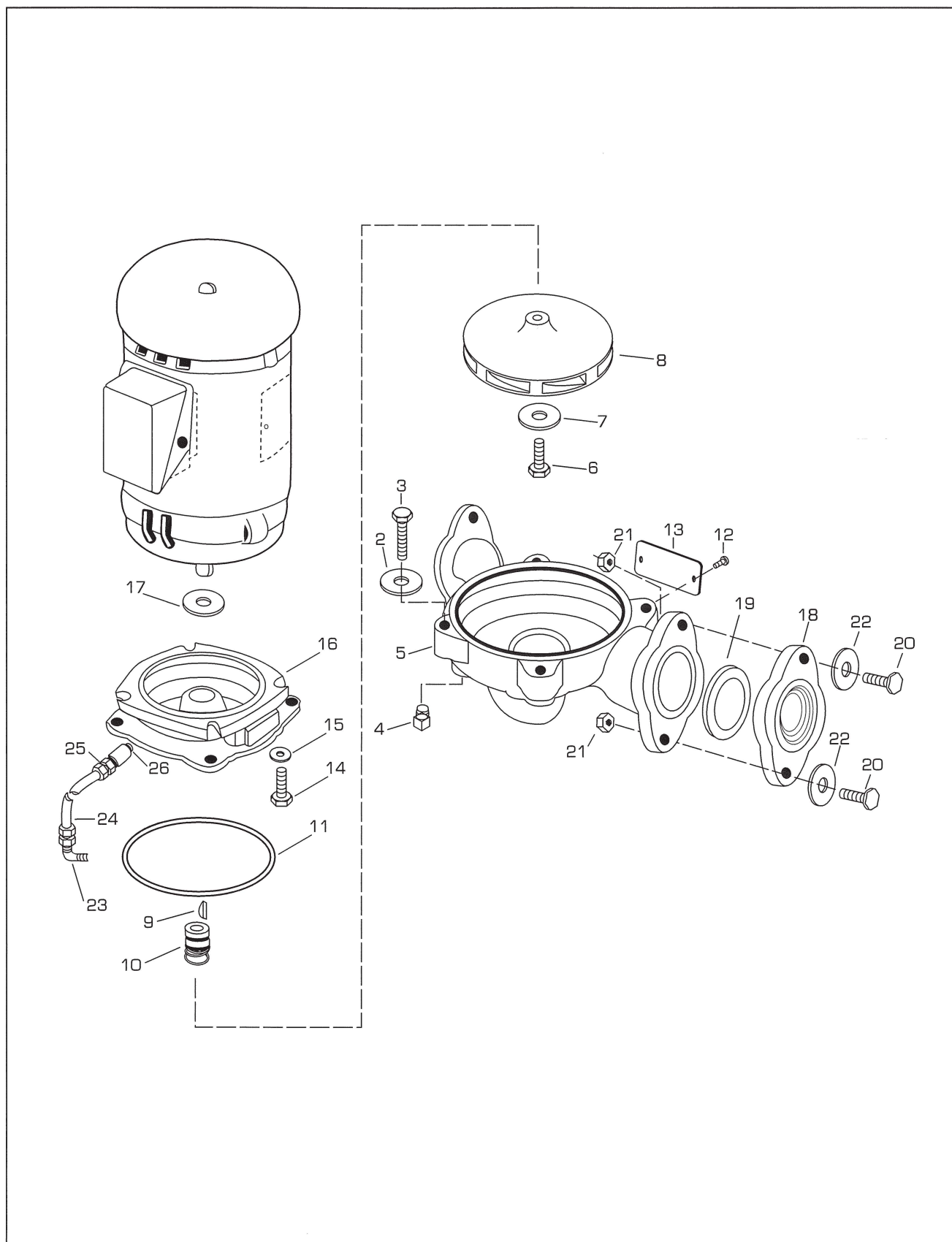

MODEL 326A  
PARTS LIST

PC. NO.	DESCRIPTION	QTY	PART NO.	MATERIAL			
				B.F.	A.B.	A.I.	
1	INSTRUCTION MANUAL	1	842-0586	999	999	999	
2	WASHER 6" PUMP	4	908-0112	080	190	080	
	WASHER 7" PUMP	4	908-0112	080	190	080	
3	CAPSCREW 6" PUMP	4	168-0380	082	190	082	
	CAPSCREW 7" PUMP	4	168-0488	082	190	082	
4	PLUG	4	600-0002	087	190	087	
5	CASING						
	MODEL "B", 1-1/4x1-1/4x6	1	180-2568	010	208	010	
	MODEL "C", 1-1/2x1-1/2x6	1	180-2569	010	208	010	
	MODEL "D", 2x2x6	1	180-2570	010	208	010	
	MODEL "E,G,H", 1-1/2x1-1/2x7	1	180-2571	010	208	010	
	MODEL "I,J,K", 2x2x7	1	180-2572	010	208	010	
6	CAPSCREW	1	168-0255	104	104	104	
7	WASHER	1	908-0599	104	104	104	
8	IMPELLER, STANDARD TRIM						
	MODEL "B", 1-1/4x1-1/4x6	1	443-2966	225	225	010	
	MODEL "C", 1-1/2x1-1/2x6	1	443-2967	225	225	010	
	MODEL "D", 2x2x6	1	443-2968	225	225	010	
	MODEL "F", 1-1/2x1-1/2x7	1	443-2969	225	225	010	
	MODEL "G", 1-1/2x1-1/2x7	1	443-2970	225	225	010	
	MODEL "H", 1-1/2x1-1/2x7	1	443-2971	225	225	010	
	MODEL "I", 2x2x7	1	443-2972	225	225	010	
	MODEL "J", 2x2x7	1	443-2973	225	225	010	
	MODEL "K", 2x2x7	1	443-2974	225	225	010	
	IMPELLER, SPECIAL TRIM						
		1-1/4x1-1/4x6	1	443-1789	225	225	010
		1-1/2x1-1/2x6	1	443-1792	225	225	010
		2x2x6	1	443-1795	225	225	010
	1-1/2x1-1/2x7	1	443-1792	225	225	010	
	2x2x7	1	443-1795	225	225	010	
9	KEY	1	472-0105	100	100	100	
10	SEAL	1	712-1004	753	764	753	
11	GASKET - 6" PUMPS	1	364-0446	457	457	457	
	GASKET - 7" PUMPS	1	364-0452	457	457	457	
12	DRIVE SCREW	2	708-0013	365	365	365	
13	NAMEPLATE	1	532-0045	114	114	114	
14	CAPSCREW	4	168-0380	082	190	082	
15	WASHER	4	908-0112	080	190	080	

PC. NO.	DESCRIPTION	QTY	PART NO.	MATERIAL		
				B.F.	A.B.	A.I.
16	BRACKET, 6" PUMP	1	116-0511	010	208	010
	BRACKET, 7" PUMP	1	116-0512	010	208	010
17	SLINGER	1	764-1002	478	478	478
18	FLANGE					
	1-1/4" FLANGE, 1-1/4" NPT	2	600-5305	010	208	010
	1-1/4" FLANGE, 1-1/2" NPT	2	600-5306	010	208	010
	1-1/2" FLANGE, 1-1/2" NPT	2	600-5307	010	208	010
	2" FLANGE, 2" NPT	2	600-5308	010	208	010
19	FLANGE SOCKET					
	1-1/4" FLANGE	2	364-0587	457	457	457
	1-1/2" FLANGE	2	364-0588	457	457	457
	2" FLANGE	2	364-0589	457	457	457
20	FLANGE BOLTS					
	1-1/4" & 1-1/2" FLANGES	4	168-0454	082	190	080
	2" FLANGES	8	168-0496	082	190	080
21	FLANGE NUTS					
	1-1/4" & 1-1/2" FLANGES	4	544-0111	080	190	080
	2" FLANGES	8	544-0113	080	190	080
22	FLANGE WASHERS					
	1-1/4" & 1-1/2" FLANGES	4	908-0069	080	190	080
	2" FLANGES	8	908-0114	080	190	080
23	TUBE CONNECTOR	1	868-3660	190	190	190
24	TUBING	-	872-0124	175	175	104
25	TUBE CONNECTOR	1	868-3581	190	190	190
26	NIPPLE, 6" PUMP		600-1156	387	104	387
	NIPPLE, 7" PUMP		600-1158	387	104	387
27	FLANGE GASKET KIT					
	CONTAINS SUFFICIENT					
	ITEMS 18, 19, 20, 21, 22 FOR					
	ONE PUMP					
	1-1/4" FLANGE, 1-1/4" NPT	1	476-0783	644	643	644
	1-1/4" FLANGE, 1-1/2" NPT	1	476-0784	644	643	644
	1-1/2" FLANGE, 1-1/2" NPT	1	476-0785	644	643	644
	2" FLANGE, 2" NPT	1	476-0786	644	643	644

## WARRANTY

Seller warrants equipment (and its component parts) of its own manufacture against defects in materials and workmanship under normal use and service for one (1) year from the date of installation or start-up, or for eighteen (18) months after the date of shipment, whichever occurs first. Seller does not warrant accessories or components that are not manufactured by Seller; however, to the extent possible, Seller agrees to assign to Buyer its rights under the original manufacturer's warranty, without recourse to Seller. Buyer must give Seller notice in writing of any alleged defect covered by this warranty (together with all identifying details, including the serial number, the type of equipment, and the date of purchase) within thirty (30) days of the discovery of such defect during the warranty period. No claim made more than 30 days after the expiration of the warranty period shall be valid. Guarantees of performance and warranties are based on the use of original equipment manufactured (OEM) replacement parts. Seller assumes no responsibility or liability if alterations, non-authorized design modifications and/or non-OEM replacement parts are incorporated. If requested by Seller, any equipment (or its component parts) must be promptly returned to Seller prior to any attempted repair, or sent to an authorized service station designated by Seller, and Buyer shall prepay all shipping expenses. Seller shall not be liable for any loss or damage to goods in transit, nor will any warranty claim be valid unless the returned goods are received intact and undamaged as a result of shipment. Repaired or replaced material returned to customer will be shipped F.O.B., Seller's factory. Seller will not give Buyer credit for parts or equipment returned to Seller, and will not accept delivery of any such parts or equipment, unless Buyer has obtained Seller's approval in writing. The warranty extends to repaired or replaced parts of Seller's manufacture for ninety (90) days or for the remainder of the original warranty period applicable to the equipment or parts being repaired or replaced, whichever is greater. This warranty applies to the repaired or replaced part and is not extended to the product or any other component of the product being repaired. Repair parts of its own manufacture sold after the original warranty period are warranted for a period of one (1) year from shipment against defects in materials and workmanship under normal use and service. This warranty applies to the replacement part only and is not extended to the product or any other component of the product being repaired. Seller may substitute new equipment or improve part(s) of any equipment judged defective without further liability. All repairs or services performed by Seller, which are not covered by this warranty, will be charged in accordance with Seller's standard prices then in effect.

THIS WARRANTY IS THE SOLE WARRANTY OF SELLER AND SELLER HEREBY EXPRESSLY DISCLAIMS AND BUYER WAIVES ALL OTHER WARRANTIES EXPRESSED, IMPLIED IN LAW OR IMPLIED IN FACT, INCLUDING ANY WARRANTIES OF MERCHANTABILITY OR FITNESS FOR A PARTICULAR PURPOSE. Seller's sole obligation under this warranty shall be, at its option, to repair or replace any equipment (or its component parts) which has a defect covered by this warranty, or to refund the purchase price of such equipment or part. Under the terms of this warranty, Seller shall not be liable for (a) consequential, collateral, special or liquidated losses or damages; (b) equipment conditions caused by normal wear and tear, abnormal conditions of use, accident, neglect, or misuse of said equipment; (c) the expense of, and loss or damage caused by, repairs or alterations made by anyone other than the Seller; (d) damage caused by abrasive materials, chemicals, scale deposits, corrosion, lightning, improper voltage, mishandling, or other similar conditions; (e) any loss, damage, or expense relating to or resulting from installation, removal or reinstallation of equipment; (f) any labor costs or charges incurred in repairing or replacing defective equipment or parts, including the cost of reinstalling parts that are repaired or replaced by Seller; (g) any expense of shipment of equipment or repaired or replacement parts; or (h) any other loss, damage or expense of any nature.

The above warranty shall not apply to any equipment which may be separately covered by any alternate or special warranties.

**PERFORMANCE:** In the absence of Certified Pump Performance Tests, equipment performance is not warranted or guaranteed. Performance curves and other information submitted to Buyer are approximate and no warranty or guarantee shall be deemed to arise as a result of such submittal. All testing shall be done in accordance with Seller's standard policy under Hydraulic Institute procedures.

**LIABILITY LIMITATIONS:** Under no circumstances shall the Seller have any liability under the Order or otherwise for liquidated damages or for collateral, consequential or special damages or for loss of profits, or for actual losses or for loss of production or progress of construction, regardless of the cause of such damages or losses. In any event, Seller's aggregate total liability under the Order or otherwise shall not exceed the contract price.

**ACTS OF GOD:** Seller shall in no event be liable for delays in delivery of the equipment or other failures to perform caused by fires, acts of God, strikes, labor difficulties, acts of governmental or military authorities, delays in transportation or procuring materials, or causes of any kind beyond Seller's control.

**COMPLIANCE WITH LAW:** Seller agrees to comply with all United States laws and regulations applicable to the manufacturing of the subject equipment. Such compliance shall include: The Fair Labor Standards Acts of 1938, as amended; Equal Employment Opportunity clauses of Executive Order 11246, as amended; Occupational Safety and Health Act of 1970 and the standards promulgated thereunder, if applicable. Since compliance with the various Federal, State, and Local laws and regulations concerning occupational health and safety, pollution or local codes are affected by the use, installation and operation of the equipment and other matters over which Seller has no control, Seller assumes no responsibility for compliance with those laws and regulations, whether by way of indemnity, warranty, or otherwise. It is incumbent upon the Buyer to specify equipment which complies with local codes and ordinances.



**AURORA®**

800 Airport Road  
North Aurora, Illinois 60542  
630-859-7000  
[www.aurorapump.com](http://www.aurorapump.com)