

K SERIES

Centrifugal Pumps for K Series
Condensate & Boiler Feed Units



Technical Specifications

The Sterlco® K Series 2' NPSH Pump is designed to pump hot condensate up to 212° F on elevated tank units. If a steam trap fails in the system, this unit will continue to operate up to 12° higher than standard units. The added inducer increases vapor pressure and prevents the whole system failing from pump cavitation. Stainless steel construction on the impeller and inducer lengthens the life of the pump and offers supreme corrosion resistance. The K Series pump is energy efficient and will reduce total cost of ownership. It is engineered to fit current Sterlco® boiler feed and condensate units, but will also be a drop in replacement for existing Sterlco® units or competitive models.

Features

Standard Features

- Pump can operate in Low NPSH conditions controlling damaging cavitation and continuing to provide steady flow
- Efficient design provides maximum capacity, minimum motor load, and the ability to operate in low NPSH conditions
- Simplistic design offers ease of maintenance and time savings versus competitors similar low NPSH pump designs
- Carbon ceramic pump seal (300°F.) with EPDM elastomers
- Stainless impeller and inducer for long life and supreme corrosion resistance
- Heavy-duty cast iron pump housing and bracket assure rigidity and long life
- 1/2 HP through 3HP motor sizes
- 1-1/2" NPT Discharge
- Stainless steel motor shaft
- Pump capacities to 85 GPM
- Discharge capacities to 115 FT.
- Motor, bracket, impeller and inducer assembly can be removed for service without disturbing discharge piping
- Available motor voltages: 115-208-230V/1, 208-230-460V/3, 575V/3
- Tri-rated motors available in 60 hertz

Sample Specifications

A Sterlco® (K Series) centrifugal pump shall be furnished (and installed as shown on the plan). It will have a capacity of _____ GPM @ _____feet total head pressure, without overloading the motor. The pump shall be designed for 2' NPSH applications (210°F - 212°F). Provisions for a seal flush shall be provided. The pump shall be close-coupled to a 3450 RPM, (open drip-proof, totally enclosed, washdown duty or explosion-proof) motor of _____HP, _____phase, _____cycle, and _____volt. The pump shall allow the motor, impeller, and inducer to be removed without disturbing the piping connections.

Example shown:
Duplex fitted K Pumps on
Cast Iron Condensate Unit



Product Diagrams



1. Motor
2. Motor Screws (4)
3. Motor Bracket
4. Pump Housing Hex Nuts
5. Lock Washers
6. Pump Housing Studs
7. O-Ring
8. Rotary Seal Assembly
9. Impeller
10. Inducer
11. Pump Housing
12. Pump Housing Plug

Removal

A) Place a mark or line using a sharpie on the motor to the bracket and also on the bracket to the housing for rotational reference when rebuilding. Remove 4 nuts that hold the housing to the bracket and remove the housing. Remove the motor drip cover.



B) While holding the end of the motor shaft use a 3/8" socket to remove the inducer counter clockwise. Remove the impeller with a screw driver or rod inside the impeller passage. Heat may be required to breakdown the thread locker for removal.

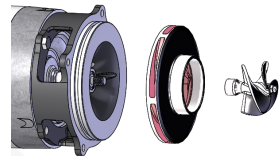

C) Remove 4 motor screws and separate the bracket from the motor. The rotating portion of the seal will unseat when the bracket is removed.

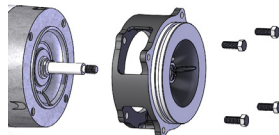

D) Remove the seal seat by pushing it out with a screw driver from the motor side. Remove the o-ring from the groove in the bracket. Clean and inspect mating surfaces. If the bracket is badly corroded it should be replaced. Clean the motor shaft and the housing bore o-ring surfaces.

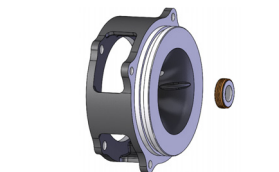

Installation

A) Coat the seal seat outer diameter and the bore in the bracket with a suitable lubricant and press the seat into the bracket making sure that it's completely square with the bottom.



B) Install the bracket onto the motor using the previous alignment marks for orientation. Clean the seal seat face.



C) Lubricate the motor shaft and rotary portion of the seal bellows and slide the rotary onto the shaft to bottom out with seal faces in contact. Place the seal spring onto the seal.

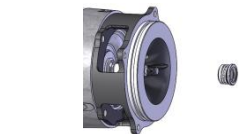

D) Use 2 drops of thread locker on the motor shaft and thread the impeller onto the shaft to seat against the shaft shoulder while holding the motor shaft. Use 2 more drops of thread locker on the motor shaft exposed threads. Thread the inducer onto the shaft and tighten it against the impeller.



E) Snap the o-ring into place on the bracket and coat with a lubricant. Lubricate the housing bore surface that the o-ring contacts. Install the housing onto the assembly using the alignment marks previously made and tighten the 4 nuts securing the housing to the bracket.

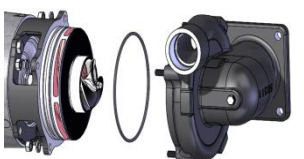

Parts List

Reference Number	Part Number	Description
1	162.00136.01.XXXXX.XX	Motor *Consult Factory
2	162.00136.02	Motor Screws (4)
3	162.00136.03	Motor Bracket
4	162.00136.04	Pump Housing Hex Nuts (4)
5	162.00136.05	Lock Washers (4)
6	162.00136.06	Pump Housing Studs (4)
7	162.00136.07	O-Ring
8	162.00136.08	Rotary Seal Assembly
9	162.00136.09.XXXX	Impeller *Consult Factory
10	162.00136.10L	Inducer (Low Flow)
	162.00136.10H	Inducer (High Flow)
11	162.00136.11	Pump Housing
12	162.00136.12	Pump Housing Plug
	162.00136.13	Seal Kit Assembly (includes a rotary seal, O-ring, seal lubricant and seal replacement instruction sheet)

Diameter	Pump & Motor Assembly Reference Number
3.25L	075.XXXXX.XX.325L
3.50L	075.XXXXX.XX.350L
4.00L	075.XXXXX.XX.400L
4.20L	075.XXXXX.XX.420L
4.45L	075.XXXXX.XX.445L
4.85L	075.XXXXX.XX.485L
5.00L	075.XXXXX.XX.500L
5.50L	075.XXXXX.XX.550L
3.60H	075.XXXXX.XX.360H
3.85H	075.XXXXX.XX.385H
4.15H	075.XXXXX.XX.415H
4.50H	075.XXXXX.XX.450H
4.80H	075.XXXXX.XX.480H
5.15H	075.XXXXX.XX.515H
5.50H	075.XXXXX.XX.550H

Product Dimensions

NOTE:
MOTOR HEIGHT RANGES FROM
9" - 13" DEPENDING ON HORSE POWER,
MODEL TYPE, AND MANUFACTURER

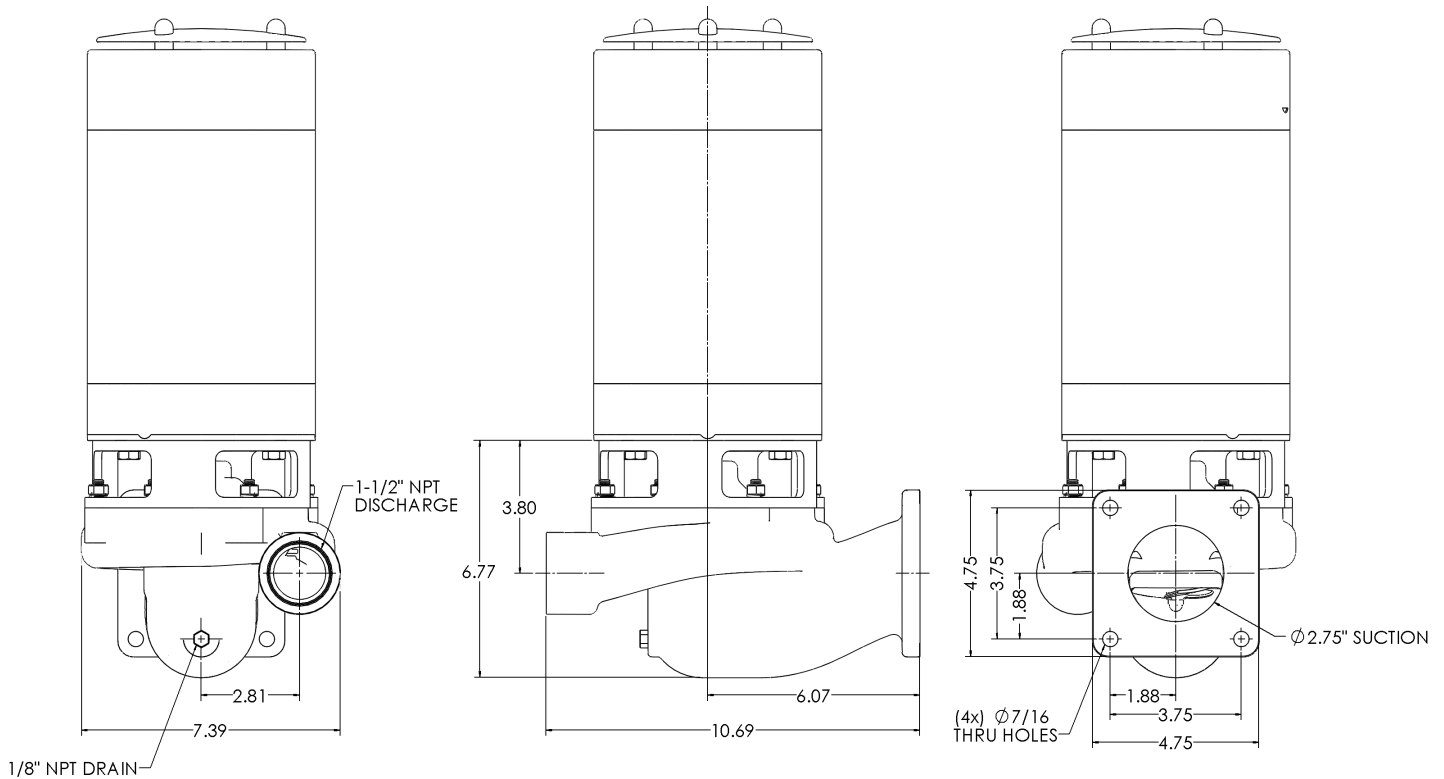

STERLING K SERIES LOW FLOW

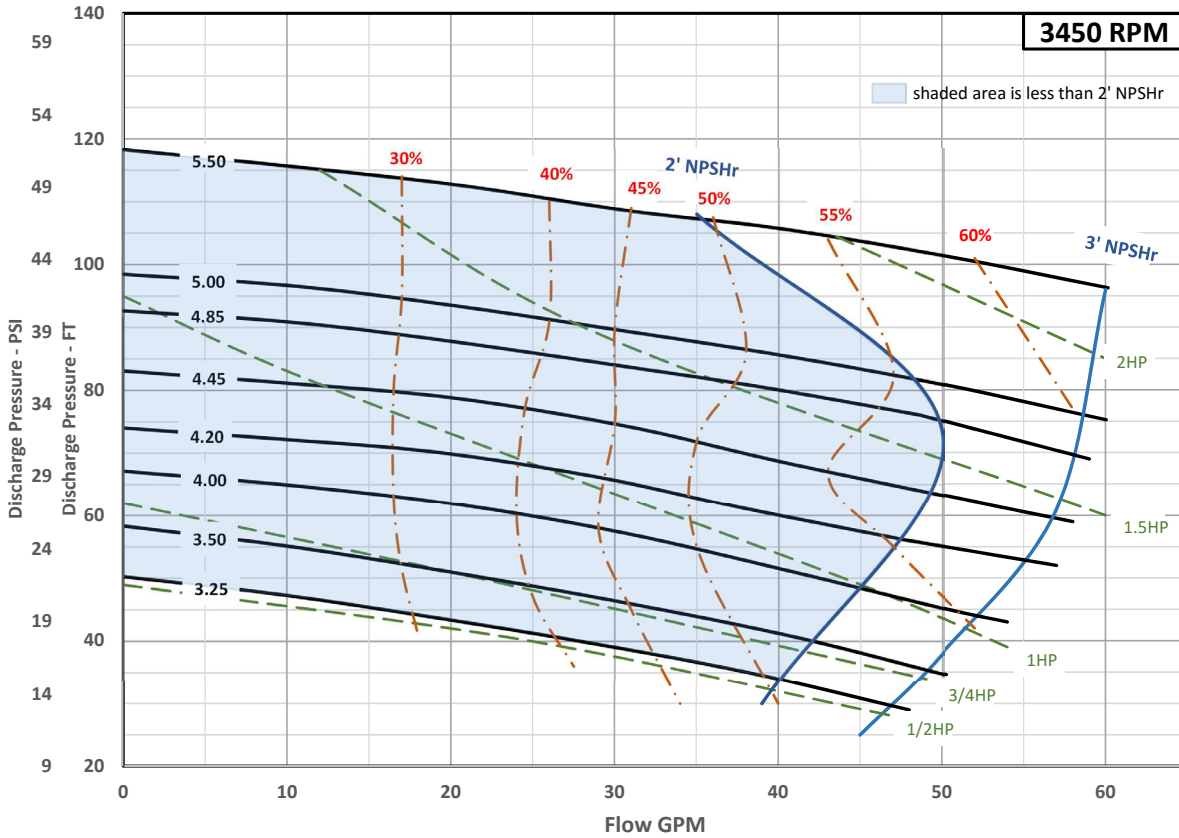

STERLING K SERIES HIGH FLOW

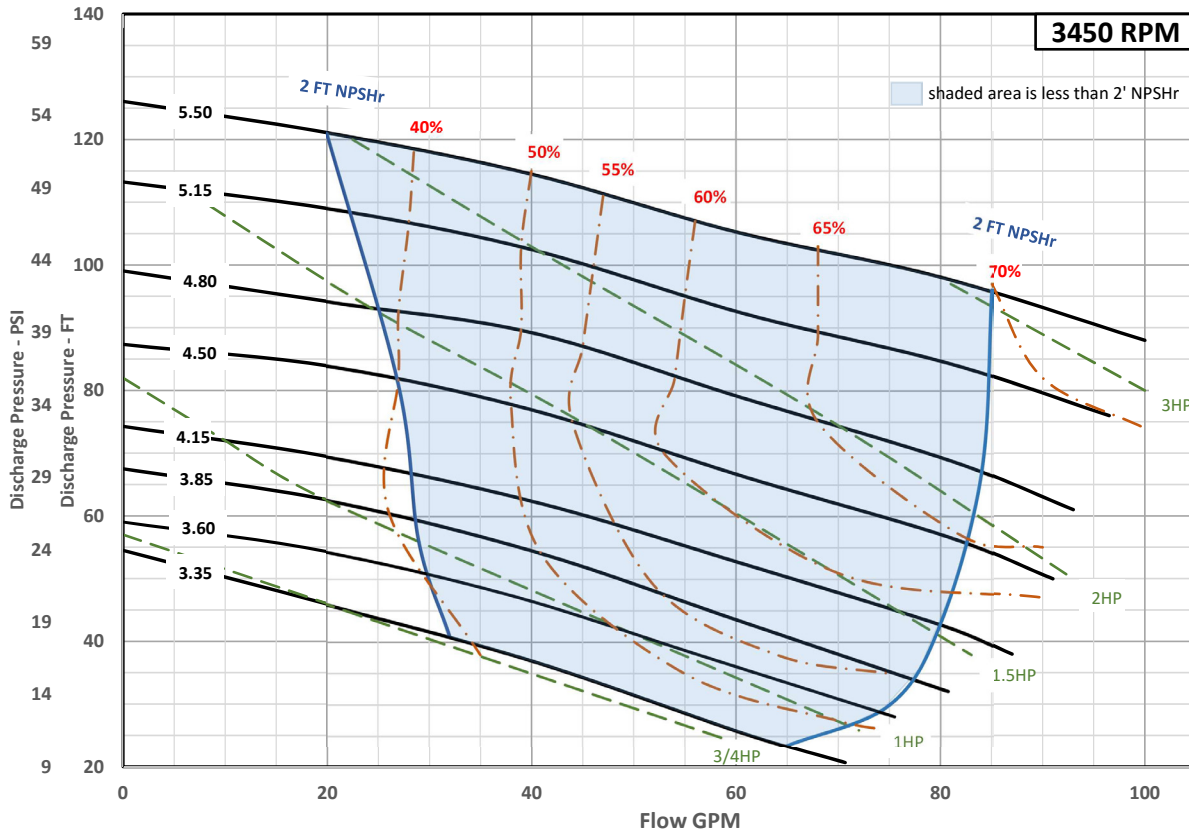

Low Flow Pump Selection Table

Pump	Model	Impeller	Diameter	HP	GPM	PSI	Mechanical Seal Kit
075.XXXXX.XX.325L	4622	162.00136.09.325L	3.25"	1/2 HP	3	20	162.00136.13
	4624			1/2 HP	6	20	162.00136.13
	4626			1/2 HP	9	20	162.00136.13
	4628			1/2 HP	12	20	162.00136.13
	46210			1/2 HP	15	20	162.00136.13
	46215			1/2 HP	22.5	20	162.00136.13
075.XXXXX.XX.350L	46220	162.00136.09.350L	3.50"	3/4 HP	30	20	162.00136.13
	46225			3/4 HP	37.5	20	162.00136.13
075.XXXXX.XX.400L	4632	162.00136.09.400L	4.00"	3/4 HP	3	30	162.00136.13
	4634			3/4 HP	6	30	162.00136.13
	4636			3/4 HP	9	30	162.00136.13
	4638			3/4 HP	12	30	162.00136.13
075.XXXXX.XX.420L	46310	162.00136.09.420L	4.20"	1 HP	15	30	162.00136.13
	46315			1 HP	22.5	30	162.00136.13
	46320			1 HP	30	30	162.00136.13
075.XXXXX.XX.445L	46325	162.00136.09.445L	4.45"	1-1/2 HP	37.5	30	162.00136.13
075.XXXXX.XX.485L	4642	162.00136.09.485L	4.85"	1 HP	3	40	162.00136.13
	4644			1 HP	6	40	162.00136.13
	4646			1-1/2 HP	9	40	162.00136.13
	4648			1-1/2 HP	12	40	162.00136.13
	46410			1-1/2 HP	15	40	162.00136.13
	075.XXXXX.XX.500L	46415	162.00136.09.500L	5.00"	1-1/2 HP	22.5	40
46420				1-1/2 HP	30	40	162.00136.13
075.XXXXX.XX.550L	4652	162.00136.09.550L	5.50"	1-1/2 HP	3	50	162.00136.13
	4654			1-1/2 HP	6	50	162.00136.13
	4656			1-1/2 HP	9	50	162.00136.13
	4658			1-1/2 HP	12	50	162.00136.13
	46510			2 HP	15	50	162.00136.13
	46515			2 HP	22.5	50	162.00136.13

For a complete pump part number, see Selecting a K Series Pump by Part Number on the next page

Model Also Applies to 4700 & 4800 Series

Mechanical Seal Kit Part Number 162.00136.13 Includes:

- (1) Rotary Seal Assembly - 162.00136.08
- (1) O-Ring - 162.00136.07
- (1) Seal Lubricant - 214.00044.00

High Flow Pump Selection Table

Pump	Model	Impeller	Diameter	HP	GPM	PSI	Mechanical Seal Kit
075.XXXXX.XX.360H	46230	162.00136.09.360H	3.60"	1 HP	45	20	162.00136.13
075.XXXXX.XX.385H	46240	162.00136.09.385H	3.85"	1-1/2 HP	60	20	162.00136.13
075.XXXXX.XX.415H	46250	162.00136.09.415H	4.15"	1-1/2 HP	75	20	162.00136.13
075.XXXXX.XX.450H	46330	162.00136.09.450H	4.50"	1-1/2 HP	45	30	162.00136.13
	46340			2 HP	60	30	162.00136.13
075.XXXXX.XX.480H	46350	162.00136.09.480H	4.80"	2 HP	75	30	162.00136.13
	46425			2 HP	37.5	40	162.00136.13
	46430			2 HP	45	40	162.00136.13
075.XXXXX.XX.515H	46440	162.00136.09.515H	5.15"	3 HP	60	40	162.00136.13
	46450			3 HP	75	40	162.00136.13
075.XXXXX.XX.550H	46520	162.00136.09.550H	5.50"	3 HP	30	50	162.00136.13
	46525			3 HP	37.5	50	162.00136.13
	46527			3 HP	40	50	162.00136.13

For a complete pump part number, see Selecting a K Series Pump by Part Number below

Model Also Applies to 4700 & 4800 Series

Mechanical Seal Kit Part Number 162.00136.13 Includes:

- (1) Rotary Seal Assembly - 162.00136.08
- (1) O-Ring - 162.00136.07
- (1) Seal Lubricant - 214.00044.00

Selecting a K Series Pump by Part Number

	Voltage	Motor HP	Motor Enclosure	Impeller Diameter	Impeller Type
075.	000	00.	00.	000	0
	110 = 115-208-230V/1 460 = 208-230-460V/3 575 = 575V/3	05 = 1/2 HP 07 = 3/4 HP 10 = 1 HP 15 = 1-1/2 HP 20 = 2 HP 30 = 3 HP	00 = Open Drip Proof 01 = TEFC 02 = Wash Down Duty 03 = Explosion Proof	325 = 3.25" Dia. 350 = 3.50" Dia. 360 = 3.60" Dia. 385 = 3.85" Dia. 400 = 4.00" Dia. 415 = 4.15" Dia. 420 = 4.20" Dia. 445 = 4.45" Dia. 450 = 4.50" Dia. 480 = 4.80" Dia. 485 = 4.85" Dia. 500 = 5.00" Dia. 515 = 5.15" Dia. 550 = 5.50" Dia.	L = Low Flow H = High Flow

