

KUNKLE SAFETY AND RELIEF PRODUCTS

MODEL 299

Drip Pan Elbow

**Features**

- The above illustration shows a discharge elbow and drip pan unit attached to a safety valve with female NPT outlet. For safety valves with flanged outlets – 2" to 4" – use companion flange, short nipple and drip pan elbow, all same size as valve outlet. 6" and 8" elbows have integral 125# ANSI B16.1 Flange.
- Important - Length of discharge piping must be kept to a minimum. For design considerations see articles: "Steam Flow Through Safety Valve Vent Pipes" by H.E. Brandmaier and M.E. Knebel (Dec. 1975) and "Analysis of Power Plant Safety and Relief Valve Vent Stacks" by G.S. Liao (Nov. 1974) available through ASME Publications.
- Each Kunkle valve is tested and inspected for pressure setting and leakage.

Applications

- Recommended installation on outlet/discharge pipe for safety valves. Used on steam service.

Installation Guide

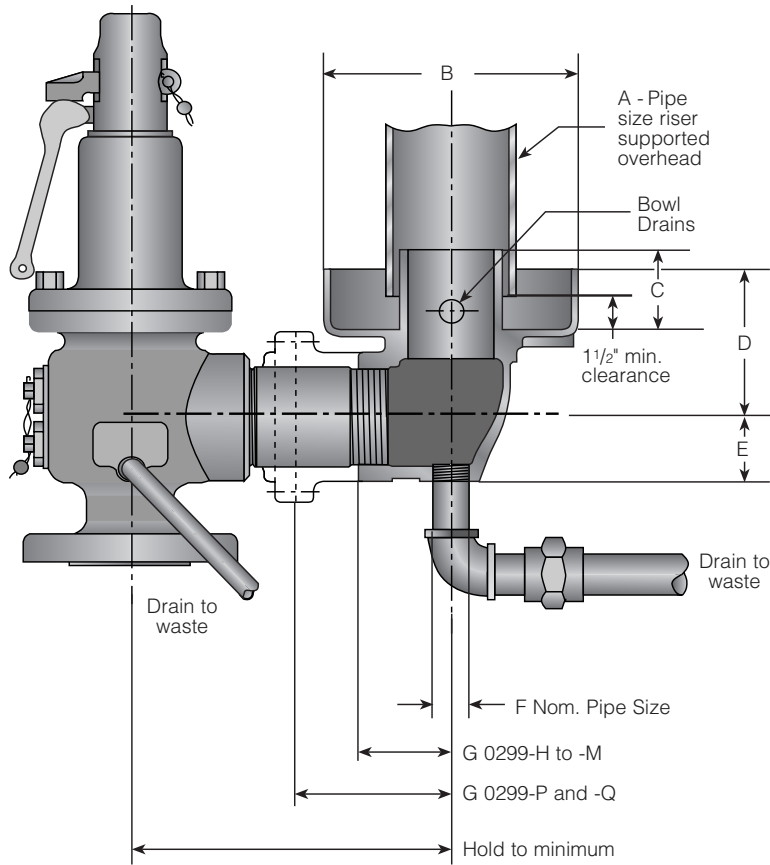

Dimensions, inches

Model	Size ¹	Dimensions, in							Weight (lb)
		A	B	C	D	E	F	G	
0299-H	2"	3	6 ¹ / ₄	2 ³ / ₈	3 ⁵ / ₈	1 ⁵ / ₈	1/2 NPT	2 ¹ / ₄	7 ¹ / ₂
0299-J	2 ¹ / ₂ "	3 ¹ / ₂ or 4	7 ³ / ₈	3	4 ⁵ / ₁₆	1 ¹⁵ / ₁₆	3/4 NPT	2 ¹¹ / ₁₆	14
0299-K	3"	4	8	3 ¹ / ₂	4 ⁷ / ₈	2 ⁵ / ₁₆	3/4 NPT	3 ¹ / ₈	19
0299-M	4"	6	9 ⁵ / ₈	4 ¹ / ₂	5 ³ / ₄	2 ⁷ / ₈	3/4 NPT	3 ³ / ₄	36
0299-P	6"	8	12 ³ / ₄	6 ⁵ / ₈	7 ⁹ / ₁₆	4 ³ / ₁₆	3/4 NPT	8	98
0299-Q	8"	10	16 ¹ / ₂	7 ¹ / ₂	9 ⁹ / ₁₆	5 ³ / ₈	1 NPT	10 ³ / ₄	180

Dimensions are for reference only.

Note:

1. Safety valve outlet and drip pan elbow size.



5500 WAYZATA BLVD # 800, MINNEAPOLIS, MN 55416 WWW.PENTAIR.COM/VALVES

KUNKLE FACILITY PHONE: 1-828-669-3700 • WWW.KUNKLEVALVE.COM

All Pentair trademarks and logos are owned by Pentair, Ltd. All other brand or product names trademarks or registered marks of their respective owners.

Because we are continuously improving our products and services, Pentair reserves the right to change specifications without prior notice. Pentair is an equal opportunity employer.