

STEAMCO

Fig. 250ANR

Class 250 Iron Body Boiler Stop Check

Angle Y Pattern

From 2 1/2" to 10"

250 P S I 450 F

500 WOG -20 to 150 F

Applicable Standards: ANSI B16.1, ANSI B16.10

PARTS AND MATERIAL DESCRIPTION			
No.	Part	Material	ASTM Spec.
1	Handwheel	Cast Iron	ASTM A126B
2	Yoke Nut	Bronze	C 83600
3	Stem	Stainless Steel	410 S.S.
4	Gland	Cast Iron	ASTM A126B
5	Packing	Non-Asbestos	Commercial
6	Stud	Steel	ASTM A193 G B7
7	Gasket	Non-Asbestos	Commercial
8	Piston	Cast Iron	ASTM A126B
9	Sleeve	Cast Iron	ASTM A126B
10	Button Trim	Cast Bronze	ASTM B271
11	Body Trim	Cast Bonze	ASTM B271
12	Body	Cast Iron	ASTM A 126B

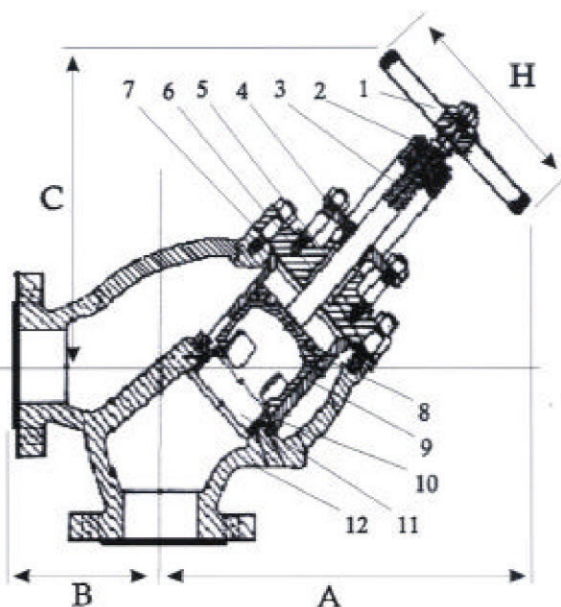

Nominal Size	Dimensions				Aprox. Weight
	A	B	C	H	
2 1/2"	14 1/2"	5 3/4"	14"	9"	107
3"	16 1/2"	6 1/4"	15"	10"	144
4"	18 1/2"	7"	17"	10"	223
5"	23"	7 7/8"	20"	14"	309
6"	25 1/2"	8 3/4"	23"	16"	417
8"	33 1/4"	10 1/2"	29"	20"	732
10"	37 3/4"	12 1/4"	32 3/4"	20"	1245