

Model	1031, 1032, 1033, 1034, 1041, 1042, 1044, 1038S
Sizes	1/2", 3/4", 1", 1 1/4", 1 1/2"
Connections	NPT
Body Material	Cast Iron
Options	Internal check valve, Thermic vent
PMO Max. Operating Pressure	250 PSIG
TMO Max. Operating Temperature	450°F
PMA Max. Allowable Pressure	250 PSIG up to 450°F
TMA Max. Allowable Temperature	450°F @ 250 PSIG



**1031/1032
1033/1034**
(No Strainer)



**1041/1042
1044/1038S**
(with Strainer)

Typical Applications

DRIP, TRACING PROCESS: IB Series inverted bucket steam traps are used in drip applications to remove condensate from steam mains and steam supply lines. For drip applications, the smaller sized units have adequate capacity. The discharge orifice of the inverted bucket trap is mounted at the top of the trap body, which makes them less susceptible to failure from dirt and debris when compared to other trap types. Since Inverted Bucket traps have poor air-handling capability, they are normally not recommended for most process applications. However, they can be used on certain process applications such as unit heaters and laundry equipment, where discharging air during system start-up is not a critical factor. F&T traps are the preferred choice for systems where air *must* be quickly discharged.

How It Works

When the trap is filled with condensate, the inverted bucket inside the steam trap loses its buoyancy and rests on the bottom of the trap. This pulls the disc off the seat allowing condensate to be discharged through the seat orifice located at the top of the trap. When steam enters, it fills the inverted bucket causing the bucket to float to the surface which closes the discharge valve, containing the steam in the system. Eventually, the steam is bled off through a small hole in the top of the bucket causing it to sink, which repeats the cycle.

Features

- Waterhammer resistant
- Suitable for superheated steam
(use internal check valve option to eliminate loss of prime)
- In-line repairability is simplified by having all internals attached to the cover
- Valve & seat are located at the top of the trap body making them less prone to clogging from debris and pipe scale
- All stainless steel internals with hardened valve & seat

Sample Specification

The steam trap shall be of an inverted bucket trap design.

Installation and Maintenance

Trap must be installed in upright position to function properly. All working components can be replaced with the trap body remaining in-line. With superheated steam, a check valve should be installed at inlet or trap may lose prime. A replacement kit containing the lever and seat assembly is a more economical option than replacing the entire steam trap. Also available are replacement screens, gaskets and buckets. When ordering replacement lever and seat assemblies, specify model and operating pressure. See Replacement Parts and Kits Section for exact cross-reference to Armstrong PCA (Pressure Change Assembly) kits.

Helpful Selection Information

Select a model with a higher maximum operating pressure (PMO) that meet or exceed the maximum steam pressure or the trap may not open. For example, the **IB-1032-14-N-250** has a PMO of 250 PSI. Choose a model that will handle the capacity requirement based on the differential pressure across the trap. Reference capacity charts.

Options

Strainer and Blowdown valve connection available on 1041, 1042, 1044 & 1038S. Thermic vent to improve air handling capability. Internal check valve for superheated or condensate backflow applications.

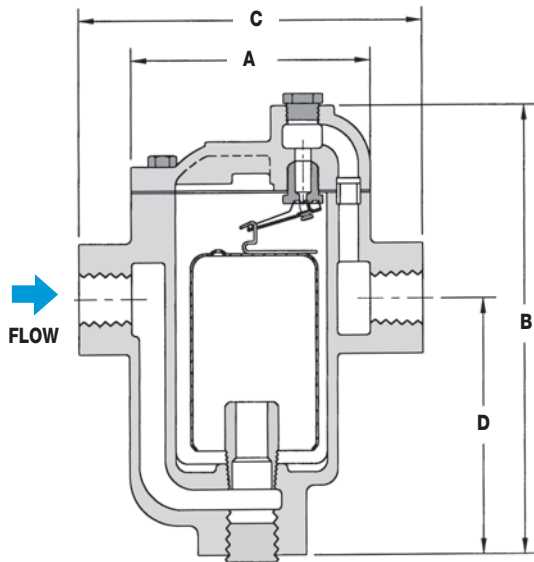

1031/1031S/1032/1033/1034
without Strainer (except 1031S)

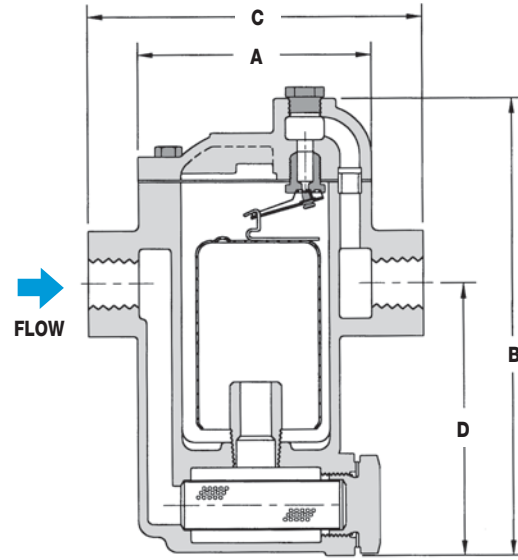

1041/1042/1044/1038S
with Strainer

DIMENSIONS & WEIGHTS – inches					
Model	A	B	C	D	Weight (lbs)
1031	3.75	5.875	5.00	2.75	5
1031S*	3.75	5.875	5.00	2.75	5
1032	3.75	6.875	5.00	4.25	6
1033	5.625	9.06	6.50	5.375	15
1034	7.00	11.75	7.75	7.03	27
1041*	3.75	6.06	5.00	3.43	5
1042*	3.75	7.06	5.00	4.43	6
1044*	7.00	12.375	7.125	7.375	30
1038S*	7.00	12.375	7.125	7.375	30

* With Integral Strainer

How to Order Options: (reference model code chart)

Check Valve (suffix CV)

Built-in Inlet Check Valve is recommended when used on Superheated Steam

Example: **IB1032-12-N-125-CV**

Thermic Vent (suffix TV)

A Thermic Vent is recommended when using a Bucket Trap on any type of process application or where the removal of air from the system is critical.

Example: **IB1032-12-N-125-TV**

Thermic Vent & Check Valve (suffix TCV)

For both Check Valve & Thermic Vent Options use Suffix Code

Example: **IB1032-12-N-125-TCV**

Blowdown Valve (add B to Model Code)

Blowdown connection is available on Models IB1038S, 1041, 1042 and 1044

Example: **IB1041B-13-N-150**

(Model IB1041, 3/4" NPT, 150 PSI max operating pressure with Blowdown & Strainer)

MATERIALS

Body & Cover	Cast Iron, ASTM A-278 Class 30
Nuts & Bolts	High-Tensile Steel
Gasket	Garlock
Bucket	Stainless Steel
Lever & Seat Assembly	Stainless Steel
Valve & Seat	Hardened Stainless Steel
Integral Strainer*	Stainless Steel

* 1031S, 1038S, 1041, 1042, 1044 models only.

How to Size / Order

From the capacity chart, select the model that can handle the working pressure of the system (PMO). Select the appropriate trap that will meet the capacity requirements at the differential pressure. Example:

Application: 1000 lbs/hr at 75 PSIG working pressure and 2 PSI differential pressure

Note: Specify Model, PMO and Connection Size

Size/Model: **IB-1034, 80 PSIG**, Specify pipe size (3/4", 1"), or **IB-1044, 80 PSIG**, Specify pipe size (3/4", 1")

Cross Reference Chart

NO STRAINER		STRAINER	
Watson McDaniel	Armstrong	Watson McDaniel	Armstrong
1031	800	1041	880
1032	811	1042	881
1033	812	1044	883
1034	813		

NO STRAINER

WITH STRAINER



1031



1041



1032



1042



1033



1044
&
1038S



1034

Conn. NPT	Model Code	PMO PSI	Weight lbs	Cross Ref. Armstrong
1/2"	IB1031-12-N-20	20	7	800
3/4"	IB1031-13-N-20			
1/2"	IB1031-12-N-80	80	7	800
3/4"	IB1031-13-N-80			
1/2"	IB1031-12-N-125	125	7	800
3/4"	IB1031-13-N-125			
1/2"	IB1031-12-N-150	150	7	800
3/4"	IB1031-13-N-150			
1/2"	IB1032-12-N-15	15	8	811
3/4"	IB1032-13-N-15			
1"	IB1032-14-N-15			
1/2"	IB1032-12-N-30	30	8	811
3/4"	IB1032-13-N-30			
1"	IB1032-14-N-30			
1/2"	IB1032-12-N-70	70	8	811
3/4"	IB1032-13-N-70			
1"	IB1032-14-N-70			
1/2"	IB1032-12-N-125	125	8	811
3/4"	IB1032-13-N-125			
1"	IB1032-14-N-125			
1/2"	IB1032-12-N-200	200	8	811
3/4"	IB1032-13-N-200			
1"	IB1032-14-N-200			
1/2"	IB1032-12-N-250	250	8	811
3/4"	IB1032-13-N-250			
1"	IB1032-14-N-250			
1/2"	IB1033-12-N-15	15	17	812
3/4"	IB1033-13-N-15			
1/2"	IB1033-12-N-30	30	17	812
3/4"	IB1033-13-N-30			
1/2"	IB1033-12-N-70	70	17	812
3/4"	IB1033-13-N-70			
1/2"	IB1033-12-N-125	125	17	812
3/4"	IB1033-13-N-125			
1/2"	IB1033-12-N-200	200	17	812
3/4"	IB1033-13-N-200			
1/2"	IB1033-12-N-250	250	17	812
3/4"	IB1033-13-N-250			
3/4"	IB1034-13-N-15	15	30	813
1"	IB1034-14-N-15			
3/4"	IB1034-13-N-30	30	30	813
1"	IB1034-14-N-30			
3/4"	IB1034-13-N-60	60	30	813
1"	IB1034-14-N-60			
3/4"	IB1034-13-N-80	80	30	813
1"	IB1034-14-N-80			
3/4"	IB1034-13-N-125	125	30	813
1"	IB1034-14-N-125			
3/4"	IB1034-13-N-180	180	30	813
1"	IB1034-14-N-180			
3/4"	IB1034-13-N-250	250	30	813
1"	IB1034-14-N-250			

Conn. NPT	Model Code	PMO PSI	Weight lbs	Cross Ref. Armstrong
1/2"	IB1041-12-N-20	20	7	880
3/4"	IB1041-13-N-20			
1/2"	IB1041-12-N-80	80	7	880
3/4"	IB1041-13-N-80			
1/2"	IB1041-12-N-125	125	7	880
3/4"	IB1041-13-N-125			
1/2"	IB1041-12-N-150	150	7	880
3/4"	IB1041-13-N-150			
1/2"	IB1042-12-N-15	15	8	881
3/4"	IB1042-13-N-15			
1/2"	IB1042-12-N-30	30	8	881
3/4"	IB1042-13-N-30			
1/2"	IB1042-12-N-70	70	8	881
3/4"	IB1042-13-N-70			
1/2"	IB1042-12-N-125	125	8	881
3/4"	IB1042-13-N-125			
1/2"	IB1042-12-N-200	200	8	881
3/4"	IB1042-13-N-200			
1/2"	IB1042-12-N-250	250	8	881
3/4"	IB1042-13-N-250			
3/4"	IB1044-13-N-15	15	37	883
1"	IB1044-14-N-15			
3/4"	IB1044-13-N-30	30	37	883
1"	IB1044-14-N-30			
3/4"	IB1044-13-N-60	60	37	883
1"	IB1044-14-N-60			
3/4"	IB1044-13-N-80	80	37	883
1"	IB1044-14-N-80			
3/4"	IB1044-13-N-125	125	37	883
1"	IB1044-14-N-125			
3/4"	IB1044-13-N-180	180	37	883
1"	IB1044-14-N-180			
3/4"	IB1044-13-N-250	250	37	883
1"	IB1044-14-N-250			
1 1/4"	IB1038S-15-N-15	15	37	883
1 1/2"	IB1038S-16-N-15			
1 1/4"	IB1038S-15-N-30	30	37	883
1 1/2"	IB1038S-16-N-30			
1 1/4"	IB1038S-15-N-60	60	37	883
1 1/2"	IB1038S-16-N-60			
1 1/4"	IB1038S-15-N-80	80	37	883
1 1/2"	IB1038S-16-N-80			
1 1/4"	IB1038S-15-N-125	125	37	883
1 1/2"	IB1038S-16-N-125			
1 1/4"	IB1038S-15-N-180	180	37	883
1 1/2"	IB1038S-16-N-180			
1 1/4"	IB1038S-15-N-250	250	37	883
1 1/2"	IB1038S-16-N-250			

Helpful Selection Information

Select a model with a higher maximum operating pressure (PMO) that meet or exceed the maximum steam pressure or the trap may not open. For example, the **IB-1032-14-N-250** has a PMO of 250 PSI. Choose a model that will handle the capacity requirement based on the differential pressure across the trap. Reference capacity charts.

CAPACITIES – Condensate (lbs/hr)																					
Model	Pipe Size	Orifice Size	PMO (PSIG)	Differential Pressure (PSI)																	
				1/4	1/2	1	2	5	10	15	20	30	50	60	70	80	100	125	150	180	200
1031 1041 1031S*	1/2", 3/4"	3/16"	20	139	200	270	340	450	560	640	690										
	1/2", 3/4"	1/8"	80	75	115	150	190	300	350	400	440	500	580	635	660	690					
	1/2", 3/4"	7/64"	125	50	80	100	145	240	280	320	350	410	490	520	560	580	640	680			
	1/2", 3/4"	#38	150	35	50	75	105	150	250	280	300	350	400	420	450	470	500	550	570		
1032	1/2", 3/4", 1"	1/4"	15	191	300	450	590	830	950	1060											
	1/2", 3/4", 1"	3/16"	30	150	235	325	410	530	700	820	880	1000									
	1/2", 3/4", 1"	5/32"	70	85	145	220	275	380	500	560	620	710	840	900	950						
	1/2", 3/4", 1"	1/8"	125	70	110	160	210	285	375	440	485	560	670	720	780	800	860	950			
	1/2", 3/4", 1"	7/64"	200	45	75	110	145	205	265	315	350	410	500	550	580	620	650	700	810	840	860
	1/2", 3/4", 1"	#38	250	15	40	80	105	155	205	240	270	320	400	500	530	550	580	630	660	690	710
1042	1/2", 3/4"	1/4"	15	191	300	450	590	830	950	1060											
	1/2", 3/4"	3/16"	30	150	235	325	410	530	700	820	880	1000									
	1/2", 3/4"	5/32"	70	85	145	220	275	380	500	560	620	710	840	900	950						
	1/2", 3/4"	1/8"	125	70	110	160	210	285	375	440	485	560	670	720	780	800	860	950			
	1/2", 3/4"	7/64"	200	45	75	110	145	205	265	315	350	410	500	550	580	620	650	700	810	840	860
	1/2", 3/4"	#38	250	15	40	80	105	155	205	240	270	320	400	500	530	550	580	630	660	690	710
1033	1/2", 3/4"	5/16"	15	350	570	850	1140	1600	1900	2100											
	1/2", 3/4"	1/4"	30	270	400	640	810	1000	1300	1600	1800	2050									
	1/2", 3/4"	3/16"	70	195	300	480	610	750	950	1200	1375	1600	1900	2000	2200						
	1/2", 3/4"	5/32"	125	130	205	320	415	595	775	910	900	1100	1380	1480	1600	1650	1800	2000			
	1/2", 3/4"	1/8"	200	75	120	200	255	365	490	585	630	700	900	980	1080	1120	1220	1400	1500	1560	1600
	1/2", 3/4"	7/64"	250	30	80	130	170	250	335	400	470	525	665	600	700	800	900	1000	1100	1180	1220
1034 1044	3/4", 1"	1/2"	15	950	1410	1880	2300	2900	3500	3900											
	3/4", 1"	3/8"	30	600	960	1300	1640	2200	2800	3300	3500	4000									
	3/4", 1"	5/16"	60	490	800	1090	1400	1750	2200	2600	2900	3500	4100	4400							
	3/4", 1"	9/32"	80	330	580	720	1070	1450	1800	2100	2400	2800	3300	3600	3800	4000					
	3/4", 1"	1/4"	125	260	430	620	810	1150	1650	1800	1900	2200	2600	2800	3000	3200	3600	3900			
	3/4", 1"	7/32"	180	200	310	470	610	880	1170	1380	1510	1800	2100	2300	2500	2700	2900	3200	3500	3700	
	3/4", 1"	3/16"	250	170	250	380	490	700	940	1100	1250	1450	1700	1800	2000	2100	2300	2700	2800	3100	3200
1038S	1 1/4", 1 1/2"	1/2"	15	1188	1763	2350	2875	3625	4375	4875											
	1 1/4", 1 1/2"	3/8"	30	760	1190	1625	2050	2750	3500	4125	4375	5125									
	1 1/4", 1 1/2"	5/16"	60	615	1000	1375	1750	2188	2750	3250	3625	4375	5125	5500							
	1 1/4", 1 1/2"	9/32"	80	420	720	900	1340	1810	2250	2625	3000	3500	4125	4500	4750	5000					
	1 1/4", 1 1/2"	1/4"	125	330	540	775	1010	1440	2063	2250	2375	2750	3250	3500	3750	4000	4500	4875			
	1 1/4", 1 1/2"	7/32"	180	250	390	590	760	1100	1470	1725	1890	2063	2375	2875	3125	3375	3625	4000	4375	4625	
	1 1/4", 1 1/2"	3/16"	250	210	320	470	610	875	1170	1380	1560	1800	2125	2250	2500	2625	2875	3375	3500	3875	4000

* 1031S only available @ PMO = 125 PSIG.



Replacement Kits

A replacement kit containing the lever and seat assembly is a more economical option than replacing the entire steam trap. Also available are replacement screens, gaskets and buckets.

When ordering replacement lever and seat assemblies specify model and operating pressure. See Replacement Parts and Kits Section for exact cross-reference to Armstrong PCA (Pressure Change Assembly) Kits.

Why use a Check Valve Option ?

The optional internal check valve allows the bucket trap to retain its prime even when exposed to superheated steam. The IB Trap must retain hot condensate inside the trap body to operate. Superheated steam or a sudden drop in inlet pressure can flash off the hot condensate inside the trap body causing the trap to lose its prime. If the steam pressure falls below the discharge pressure on the outlet side of the steam trap, the internal check valve will stop the back flow of condensate into the steam system. When discharging to a condensate return line, a check valve is always recommended.

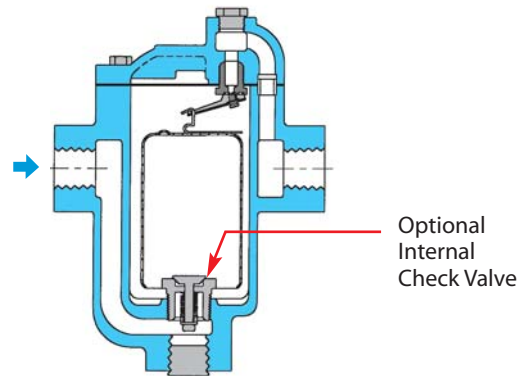

Steam Trap Installed Above Condensate Collection Point

In this example, condensate must travel upwards to reach the trap. Under this condition, it is possible for condensate to flow from the condensate return line into the steam coils, thereby flooding the system. The internal check valve, inside the IB trap, prevents the back flow of condensate.

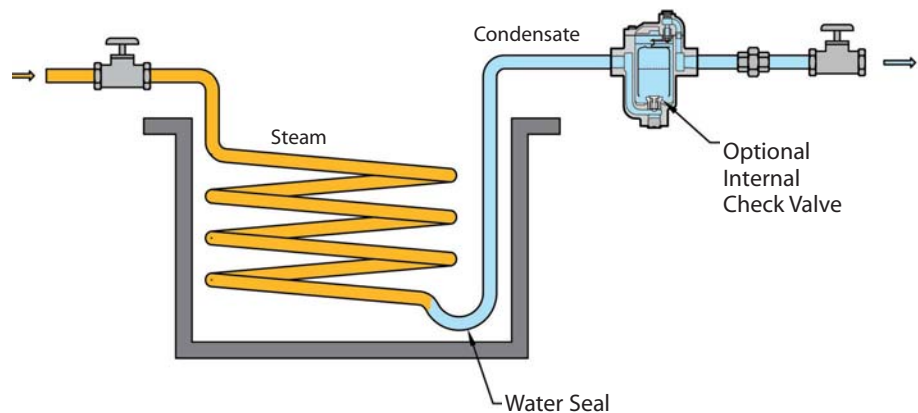

Steam Trap Discharging into Elevated Condensate Return Line

When a steam trap discharges condensate to an elevated location, a check valve should be used to stop condensate from flowing backwards into the steam system.

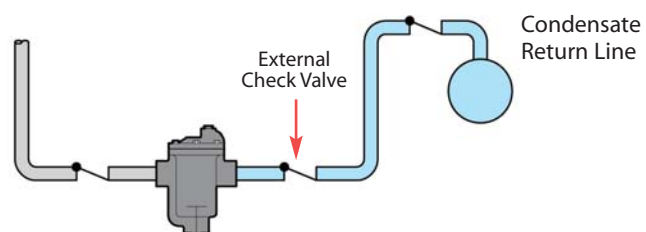

Why use a Thermic Vent ?

The Thermic Vent is used for discharging air from the steam system during start-up.

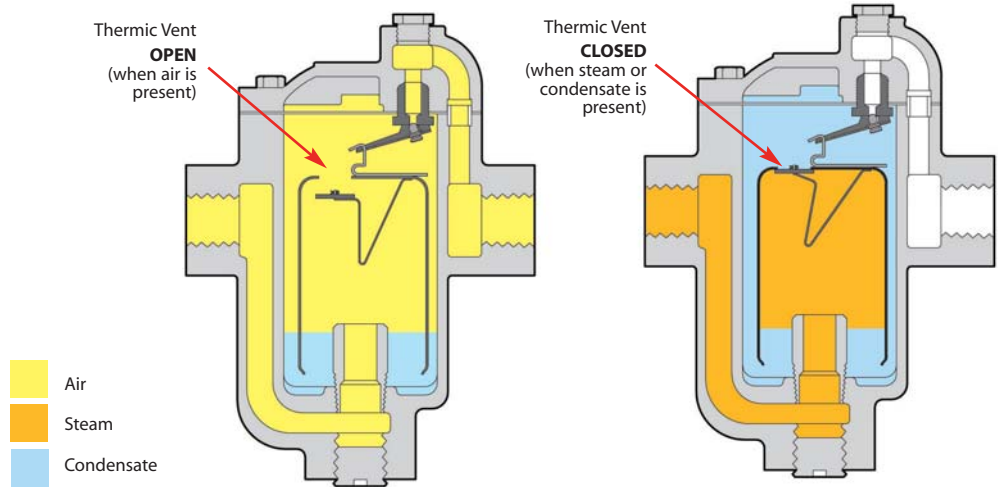

Blowdown Valve Connection

A Blowdown Valve connection is available as an option on the **1041, 1042, 1044, and 1038S** models. This simplifies maintenance by allowing the strainer to be cleaned without removal. User to supply blowdown valve.

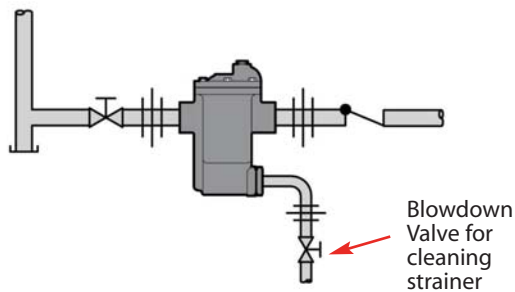
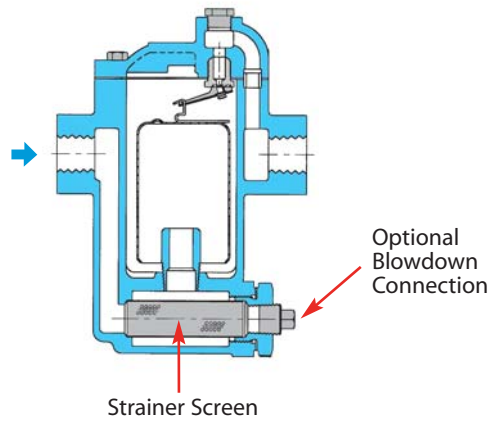

1031S

The **1031S** is equipped with a small protection screen to guard against dirt in the steam system. It is a more economical alternative than the 1041 which has a full-port strainer. Specifically designed for use in laundries. Available in 125 PSIG model only.

