



TYPE E MAIN VALVE

SIZES 3/8" – 12"
PRESSURES to 600 PSIG at 750°F

- Normally Closed
- Single Seat
- Balanced Metal Diaphragms
- Protected Main Spring
- Fluid, Gas & Vapor Applications
- Multiple Trims for Precise Sizing
- ANSI/FCI 70-2 Class IV Shutoff
- FCI 70-3 Class VI Shutoff
- Virtually Frictionless for Long Service Life
- Packless Construction
- Easy In-line Maintenance
- Wide Variety of Pilots for Many Applications
- Minimum Operating ΔP 10 psi (.7 bar)
- Lifetime Warranty against Wiredrawing of Seat & Disc*

TYPE E MAIN VALVE

APPLICATION DATA

- Pressure Regulating for Steam Distribution
- Regulating for Process Control (Temperature or Pressure)
- Maintain Back Pressure or Differential Pressure
- For use with Self-contained, Pneumatic or Electronic Pilots
- Single Point or Multiple Use Applications
- Slow Start-up or Shutdown

SIZING INFO
PAGE 106

VALVE RATINGS

Valve Ends ASME/ANSI	Pressure PSIG (bar)	Temperature °F (°C)
-------------------------	------------------------	------------------------

CAST IRON

B16.4 Class 250 NPT	250 (17.2)	@ 450 (232)
B16.1 Class 125 Flanged	125 (8.6)	@ 450 (232)
B16.1 Class 250 Flanged	250 (17.2)	@ 450 (232)

CAST STEEL

B16.34 Class 300 NPT	300 (21.0)	@ 600 (315)†
B16.34 Class 150 Flanged	150 (10.3)	@ 500 (260)
B16.34 Class 300 Flanged	300 (21.0)	@ 600 (315)†
B16.34 Class 600 Flanged	600 (41.4)	@ 600 (315)†

†750°F (400°C) construction available on request.
Other pressure/temperature ratings available; consult factory.
Maximum downstream pressure is 300 psi.

Canadian Registration # OC 0591.9C

Installation Tip: Add EZ Connections for ease of maintenance
SEE PAGE 40

OPTIONS (SEE PAGE 42)

- Composition Disc
- Parabolic Disc
- Balanced Construction
- Integral Mount Pilot
- Insulcap Insulating Jacket
- Secoweld
- High Temperature Construction
- Dashpot
- Low ΔP (LP) Main Spring
- EZ Connections

TYPICAL CONFIGURATIONS

- PRESSURE REDUCINGTYPE ED SERIES
- AIR ADJUSTEDTYPE EA SERIES
- BACK PRESSURETYPE EQ SERIES
- PUMP GOVERNORTYPE EP SERIES
- LOAD ALLOCATINGTYPE EFD
- AIR CONTROLLEDTYPE EAP60
- ELECTRONIC SLOW STARTTYPE ED208D
- SOLENOID CONTROLLEDTYPE EMD
- SOLENOID ACTUATEDTYPE EM
- DIFFERENTIALTYPE EN
- TEMPERATURE CONTROLTYPE ET SERIES

RATED FLOW COEFFICIENTS (Cv)

SEAT FACTOR	REGULATOR SIZE														
	3/8	1/2	3/4	1	1 1/4	1 1/2	2	2 1/2	3	4	5	6	8	10	12
Full	1.5	2.8	5.4	8.8	14.1	19.8	31	44	74	109	169	248	444	706	1113
Full 75 %	—	2.2	4.2	7.2	11.1	15.9	22.9	37	56	88	136	188	353	558	880
Full 50 %	—	1.7	2.6	6.3	7.4	11.3	17.7	25	42	65	94	139	252	400	631
Normal	.66	1.55	4.8	7.5	10.4	14.6	17.6	24	43	78	115	151	249	377	631
Normal 75 %	—	—	—	—	—	—	—	18	34	62	89	110	187	294	463
Normal 50 %	—	—	—	—	—	—	—	14	26	46	65	83	139	230	363

* When installed according to factory specifications.

TYPE E MAIN VALVE

SPECIFICATION

The valve shall be self-operated, external pilot type, single seated, metal diaphragm actuated, normally closed design. The valve will function quickly and shut tight on dead end service. Internal parts including seats, discs, stems and diaphragms shall be of stainless steel. There shall be no springs in the steam space and no stuffing box. The valve shall be easy to maintain with all parts accessible without removal from the line.

MATERIALS OF CONSTRUCTION

Body, Cast IronASTM A126 Cl. B
 Body, Cast SteelASTM A216 WCB
 Stem303 St. Stl. ASTM A582
 Disc 3/4 - 5"420 St. Stl. ASTM A743 CA-40
 Disc 6 - 12"304 St. Stl. ASTM A167/A240
 Seat 3/4 - 5"420 St. Stl. ASTM A743 CA-40
 Seat 6 - 12"316 St. Stl. ASTM A743-79 CF-8M
 GasketNon-asbestos
 DiaphragmStainless Steel MIL-S-5059C
 SpringSteel

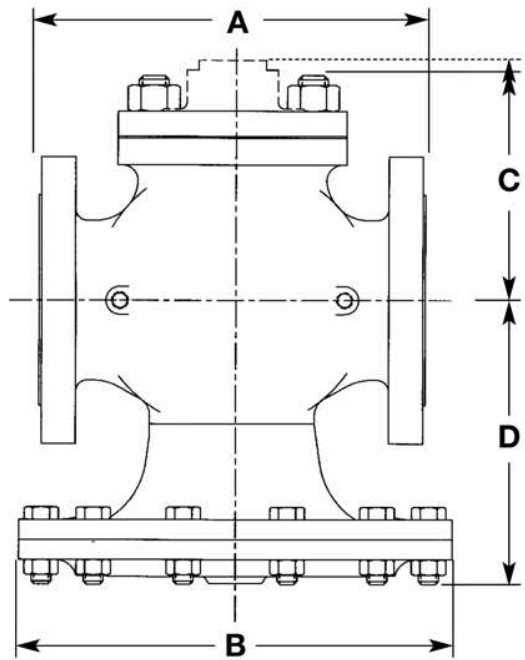

TYPE E
MAIN VALVE

TYPE E MAIN VALVE

FITTINGS ON
PAGE 44

DIMENSIONS inches (mm) AND WEIGHTS pounds (kg)

SIZE	FACE TO FACE DIMENSIONS					B	C				D*	APPROX. WT.				
	A						Std. Mount	Integral Mount				ANSI NPT	ANSI 125,150	ANSI 250,300	ANSI 600	
	ANSI NPT	ANSI 125,150	ANSI 250	ANSI 300	ANSI 600			ANSI 600	Cl & Brz.	Steel						Steel 600
3/8 (10)	4 3/8 (111)	—	—	—	—	5 7/8 (149)	2 3/4 (70)	—	3 1/2 (89)	3 1/2 (89)	—	5 1/4 (133)	14 (6)	—	—	—
1/2 (12)	4 3/8 (111)	—	—	—	6 (152)	5 7/8 (149)	2 3/4 (70)	2 3/4 (70)	3 1/2 (89)	3 1/2 (89)	3 5/8 (92)	5 1/4 (133)	14 (6)	—	—	20 (9.1)
3/4 (19)	4 3/4 (111)	—	—	—	6 3/8 (162)	6 1/2 (165)	2 7/8 (73)	3 7/8 (98)	3 3/8 (92)	3 3/4 (95)	4 1/2 (114)	5 1/2 (140)	18 (8)	—	—	28 (13)
1 (25)	5 3/8 (137)	5 1/2 (140)	6 (152)	6 1/2 (165)	6 1/2 (165)	7 (178)	3 5/8 (92)	4 1/4 (108)	4 3/8 (111)	4 3/8 (111)	4 3/4 (121)	6 1/4 (159)	23 (10)	26 (12)	31 (14)	32 (15)
1 1/4 (32)	6 1/2 (165)	6 3/4 (171)	7 1/4 (184)	7 7/8 (200)	7 7/8 (200)	7 7/8 (200)	4 1/8 (105)	4 5/8 (117)	4 (102)	4 5/8 (117)	5 (127)	6 1/2 (165)	33 (15)	37 (17)	41 (19)	45 (20)
1 1/2 (38)	7 1/4 (184)	6 7/8 (175)	7 3/8 (187)	8 (203)	8 (203)	8 3/4 (222)	4 3/8 (111)	5 1/8 (130)	4 3/8 (111)	5 (127)	—	7 1/8 (181)	43 (20)	47 (21)	55 (25)	58 (26)
2 (51)	7 1/2 (191)	8 1/2 (216)	9 (229)	10 1/4 (260)	10 1/4 (260)	9 7/8 (251)	5 1/4 (133)	5 3/4 (146)	5 (127)	5 5/8 (143)	5 3/4 (146)	7 5/8 (194)	62 (28)	73 (33)	78 (35)	83 (38)
2 1/2 (64)	—	9 3/8 (238)	10 (254)	11 1/4 (286)	11 1/4 (286)	10 7/8 (276)	5 3/4 (146)	7 7/8 (200)	5 1/2 (140)	6 (152)	8 1/4 (210)	8 3/8 (213)	—	95 (43)	100 (45)	130 (59)
3 (76)	—	10 (254)	10 3/4 (273)	12 1/4 (311)	12 1/4 (311)	11 3/4 (298)	6 5/8 (168)	9 1/8 (232)	6 3/8 (162)	7 1/8 (181)	—	9 1/4 (235)	—	125 (57)	140 (64)	175 (80)
4 (102)	—	11 7/8 (302)	12 1/2 (318)	12 1/2 (318)	14 1/2 (368)	14 3/4 (375)	7 5/8 (194)	10 5/8 (270)	7 1/4 (184)	8 (203)	—	11 7/8 (302)	—	210 (95)	230 (105)	310 (141)
5 (127)	—	13 5/8 (346)	14 1/2 (368)	14 1/2 (368)	16 1/2 (419)	16 7/8 (429)	8 1/2 (216)	12 1/2 (318)	8 1/8 (206)	8 1/2 (216)	—	12 1/2 (318)	—	295 (134)	310 (141)	490 (223)
6 (152)	—	15 1/8 (384)	16 (406)	16 (406)	17 3/8 (441)	19 3/4 (502)	10 (254)	13 3/4 (349)	9 1/2 (241)	9 1/2 (241)	13 3/8 (346)	14 1/8 (359)	—	420 (191)	470 (214)	655 (298)
8 (203)	—	19 (483)	20 (508)	20 (508)	21 5/8 (549)	22 1/2 (572)	11 1/2 (292)	15 3/8 (391)	11 1/4 (286)	11 3/4 (298)	—	17 1/4 (438)	—	700 (318)	710 (323)	1070 (486)
10 (254)	—	23 5/8 (600)	25 (635)	25 (635)	—	28 (711)	13 3/4 (349)	—	—	—	—	23 3/8 (594)	—	1240 (563)	1300 (591)	—
12 (305)	—	26 1/2 (673)	28 (711)	28 (711)	—	33 (838)	15 7/8 (403)	—	—	—	—	25 1/4 (641)	—	2060 (936)	2140 (972)	—

*Add 65% to D dimension for stem removal clearance.