

Model	FT
Sizes	3/4", 1", 1 1/4", 1 1/2", 2"
Connections	NPT
Body Material	Cast Iron
PMO Max. Operating Pressure	75 PSIG
TMO Max. Operating Temperature	Saturated Steam Temperature
PMA Max. Allowable Pressure	75 PSIG up to 450°F
TMA Max. Allowable Temperature	450°F @ 75 PSIG



Typical Applications

DRIP, PROCESS: FT Series steam traps are designed for operating pressures up to 75 PSIG. These float and thermostatic traps are used for lower pressure HVAC and light industrial process applications. They are used on unit heaters, water heaters, pressing machines, heat exchangers and coils. For drip applications, such as draining steam mains and steam supply lines, use 3/4" FT-075 (FT73-075-13-N). F&T traps have excellent air-handling capability, which make them a better choice than Inverted Bucket traps for most process applications. FT Series traps have a dual inlet-outlet H-Pattern connection allowing for additional flexibility in installation.

How It Works

Float and thermostatic traps contain a float and seat mechanism with a separate thermostatic element which work together to remove both condensate and air from the steam system. The float, which is attached to a valve, rises and opens the valve when condensate enters the trap. This allows the condensate to discharge. Air is discharged through the thermostatic air vent to the outlet side of the trap. Steam entering the trap causes the thermostatic element to expand, closing the air vent and trapping the steam.

Sample Specification

The trap shall be of float and thermostatic design with cast iron body. Thermostatic element to be welded stainless steel. Float and seating material to be stainless steel. Trap must be in-line repairable.

Features

- H-pattern design allows piping from either side of the steam trap (there are two inlet ports at top and two outlet ports at bottom)
- F&T traps have excellent air handling capability allows air to be discharged rapidly and steam to enter the system quickly during start-up
- Welded stainless steel thermostatic air vent resists shock from waterhammer
- In-line repairable (all internals are attached to cover)

Installation and Maintenance

The trap must be installed upright and level for the float mechanism to operate properly. All internal components can be replaced with the trap body piped in-line. Repair kit includes thermostatic element, valve seat and disc, float and sealing gasket.

Helpful Selection Information

Select a model that can handle the maximum working pressure of the steam system. For example, the FT3-015 has a maximum working pressure of 15 PSI. Consult capacity tables to properly size unit. Available in 3/4" through 2" NPT connections. Select these models for steam systems with maximum working pressure of 75 PSIG.

Demonstration of H-Style piping connections:

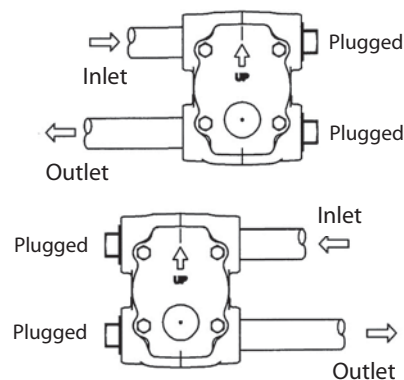
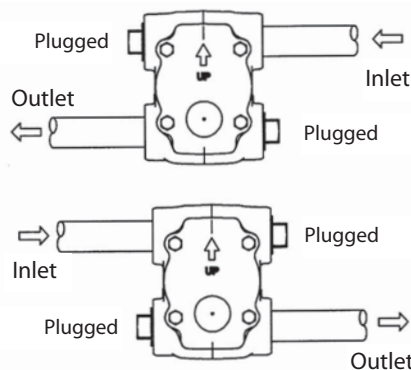

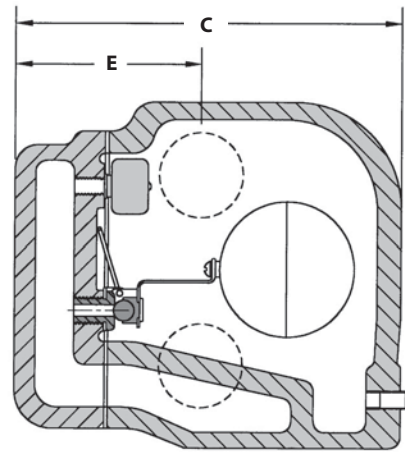
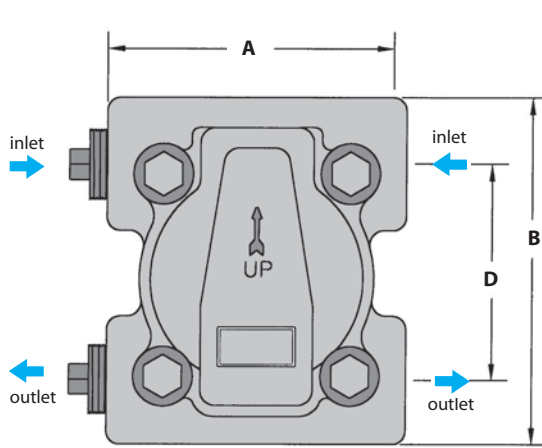

DIMENSIONS & WEIGHTS – inches/pounds						
Model	A	B	C	D	E	Weight
FT-3, FT-4, FT-33 FT-34, FT-73, FT-74	4.125	5.00	5.125	3.125	2.75	7.50
FT-6, FT-35, FT-36 FT-75, FT-76	5.00	6.81	6.47	4.125	3.43	13.0
FT-7, FT-37L, FT-77L	6.375	7.68	8.218	5.25	4.41	21.0
FT-8, FT-38, FT-78 FT-S8-15, FT-S8-75	6.50	11.0	8.968	7.468	4.531	40.0

MATERIALS	
Body & Cover	Cast Iron, ASTM A-126 Class B
Nuts & Bolts	High-Tensile Steel
Gasket	Grafoil/Garlock
Float	Stainless Steel
Valve & Seat	Stainless Steel
Thermostatic Assembly	Stainless Steel Bellows & Valve

How to Size / Order

The maximum operating pressure (PMO) rating of model selected must meet or exceed the maximum steam pressure or the trap may not open. For example; the FT-35-030 has a PMO of 30 psi. For drip applications, a 3/4" FT size is sufficient to exceed warm-up loads with a 2X safety factor. The condensate loads (lbs/hr) for process applications are normally calculated at the maximum steam pressure; then a safety margin is applied in order to select a trap with sufficient capacity at lower pressures. Reference full explanation of Safety Load Factors in Steam Traps Introduction section.

For Example: Process application has a maximum steam inlet pressure of 50 psi, a maximum condensate load of 1,700 lbs/hr and is discharging to a condensate return line with a possible back pressure of 10 psig. $\Delta P = 50 - 10 = 40$ PSI

To select trap: If the Safety Load Factor is chosen to be 2X max capacity at max differential pressure, then Trap should be selected based on 3,400 lbs/hr (1,700 x 2 = 3,400) at 40 PSI differential pressure with a PMO in excess of 50 PSIG

Selection: FT77L-075-16-N, PMO=75 PSIG, 1 1/2" NPT with a condensate capacity of 3,750 lbs/hr at 40 PSI differential pressure.

CAPACITIES – Condensate (lbs/hr)

Model Code	PMO (PSIG)	Pipe Size	Orifice Size	$\Delta P =$ Differential Pressure (PSI)															
				1/4	1/2	1	2	3	5	10	15	20	25	30	40	50	60	75	
FT3-015-13-N	15	3/4"	9/32"	340	440	600	830	990	1280	1790	2150								
FT4-015-14-N	15	1"	9/32"	340	440	600	830	990	1280	1790	2150								
FT6-015-15-N	15	1 1/4"	25/64"	850	1100	1460	2000	2350	2950	4000	4800								
FT7-015-16-N	15	1 1/2"	1/2"	1300	1700	2050	2550	2900	3500	4400	5300								
FT8-015-17-N	15	2"	21/32"	2500	3150	4000	5700	6100	6800	8300	9800								
FTS8-015-17-N	15	2"	15/16"	4400	5850	7400	9200	10300	12600	15300	18100								
FT33-030-13-N	30	3/4"	11/64"	220	300	405	530	650	890	1210	1485	1705	1865	2010					
FT34-030-14-N	30	1"	11/64"	220	300	405	530	650	890	1210	1485	1705	1865	2010					
FT35-030-14-N	30	1"	1/4"	450	600	880	1205	1420	1845	2560	3230	3715	4100	4405					
FT36-030-15-N	30	1 1/4"	1/4"	450	600	880	1205	1420	1845	2560	3230	3715	4100	4405					
FT37L-030-16-N	30	1 1/2"	7/16"	600	800	1200	1680	2210	2600	3500	4500	5200	5700	6100					
FT38-030-17-N	30	2"	13/32"	1550	2045	2625	3560	4260	5660	7890	9440	10500	11360	12095					
FT73-075-13-N	75	3/4"	9/64"	140	195	265	360	430	580	770	990	1110	1210	1290	1430	1560	1680	1830	
FT74-075-14-N	75	1"	9/64"	140	195	265	360	430	580	710	990	1110	1210	1290	1430	1560	1680	1830	
FT75-075-14-N	75	1"	#16	270	360	485	660	780	1020	1430	1740	1980	2200	2420	2670	2910	3135	3370	
FT76-075-15-N	75	1 1/4"	#16	270	360	485	660	780	1020	1430	1740	1980	2200	2420	2670	2910	3135	3370	
FT77L-075-16-N	75	1 1/2"	5/16"	340	460	690	900	1200	1400	1900	2350	2700	3000	3250	3750	4150	4500	4700	
FT78-075-17-N	75	2"	5/16"	800	1075	1300	1700	2000	2600	3750	4350	4700	5050	5400	5960	6500	6950	7550	
FTS8-075-17-N	75	2"	13/32"	1360	1800	2100	2800	3300	4300	6300	7300	8000	8500	9000	10000	11000	11600	12500	