

TASCO VALVES

**BRONZE
FLOCONTROL
"500 BRINELL"**

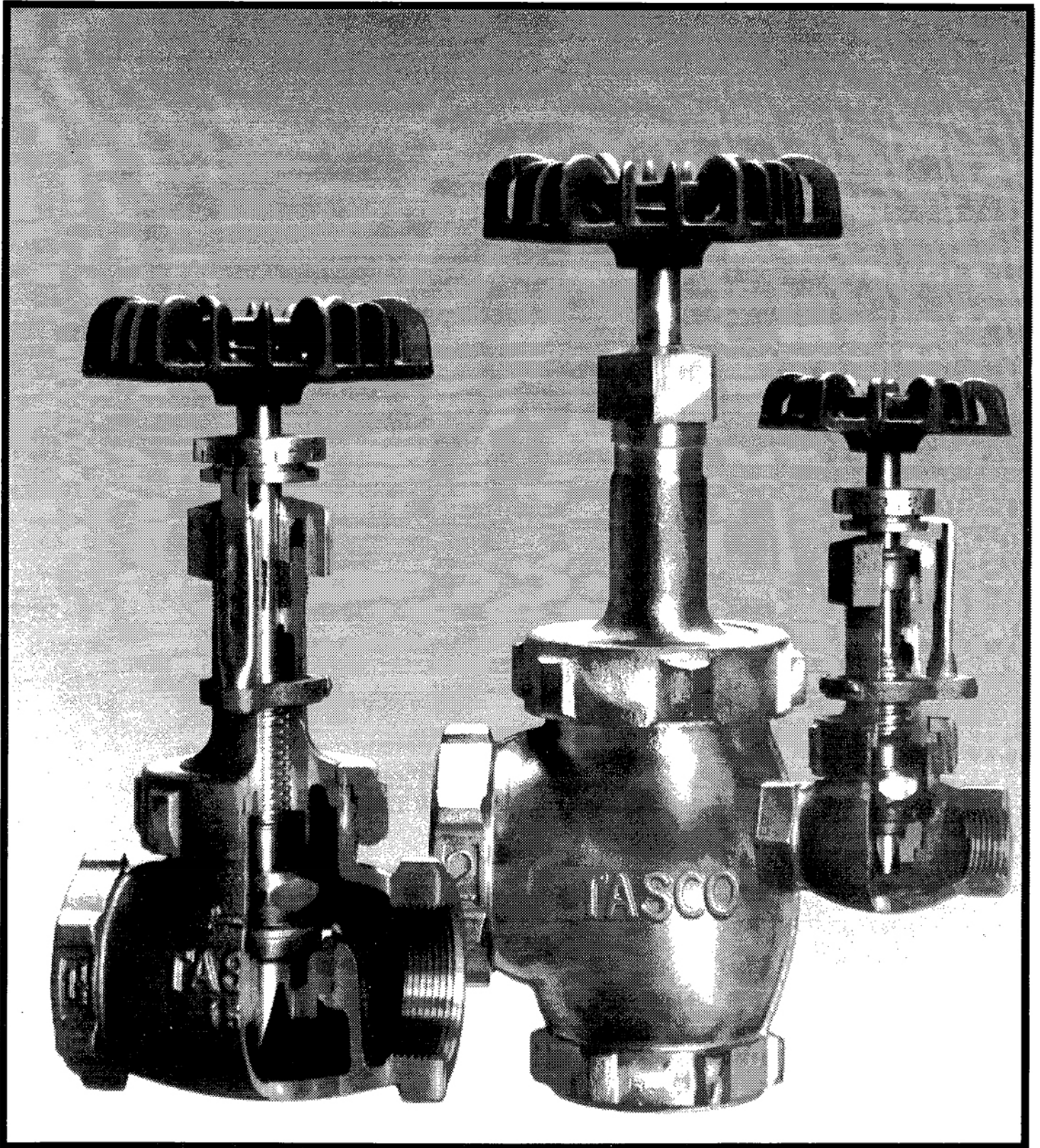

TASCO VALVES UNLIMITED

Boiler Supplies International
143 McDonough Pkwy
McDonough, GA 30253
Phone: 1-800-780-3776 Fax 770-957-9563

TASCO Valves combine two essential utility features...highest efficiency and lowest maintenance...in providing economical service for process, power, petroleum, chemical, petrochemical, and all types of general industry applications.

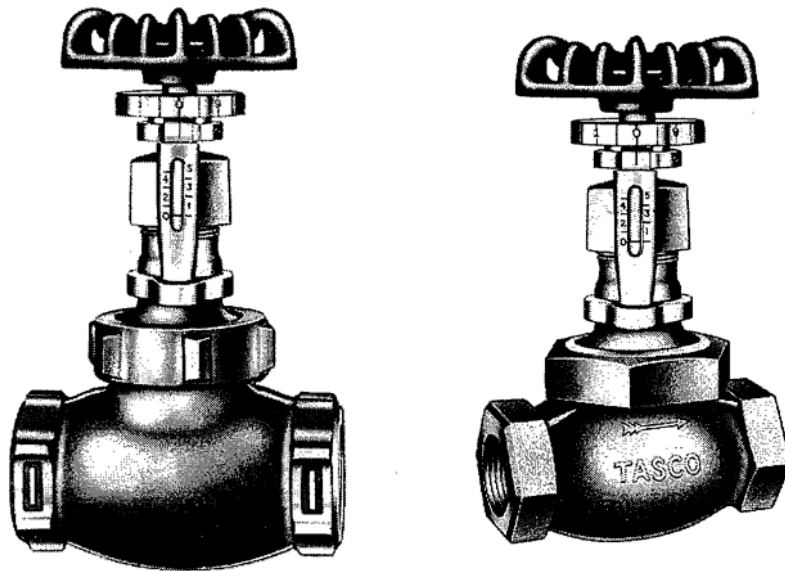
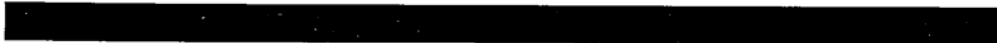

Prominent plus-valve of the "500 Brinell" bronze TASCO " Valve is its rugged diaphragm construction, or ability to withstand expansions in piping systems and strains from installation and piping: lowered operating cost, this valve can be repacked under pressure: superhard stainless steel seats and discs assure longer valve life and minimize maintenance costs. Included in this bronze group is the TASCO Flocontrol Valve, a combination valve and flow control instrument equipped with a special micrometer dial and pointer; this enables the operator to set the valve opening to within one-twentieth of a turn of the handwheel. Ranges: up to 300 psi; Sizes: 1/4" - 2", angle types.

Introduction.....pages 1-3
Selectionpages 4-7
Engineeringpages 8-10

"500 Brinell"

The preference by valve users for TASCO "500 Brinell" Bronze Valves has been built-up over a period of 80 years' experience and skill in the manufacture of valves. This preference is maintained because TASCO "500 Brinell" Bronze Valves continue to perform at a minimum of operating and maintenance costs over a longer period than ordinary bronze valves.

- bottom seating** — always under compression . . . no shoulder to introduce
- a** tension . . . eliminates possibility of seat cracking.
- b** "500 Brinell" (thru-and-thru hardness) stainless steel seat — eliminates wire drawing, galling and steam cutting.
- c** "500 Brinell" (thru-and-thru hardness) stainless steel disc — no wire drawing, galling, steam cutting.
- d** **external threads** on hardened disc — material always under compression . . . eliminates possibility of cracking.
- e** **greater strength** in diaphragm — eliminates distortion in piping installation . . . conical for minimum flow resistance.
- f** **body** — high tin bronze specially developed for strength at elevated temperatures.
- g** **stem** — Acme thread . . . long wearing silicon bronze . . . large diameter, not easily bent.
- h** **stem end** — projects deep into disc . . . cannot wear off . . . disc closely guided by diameter of stem. Due to light pressure, wear does not occur and disc remains closely guided thru life of valve.
- i** **back seat** — for packing under pressure . . . direct seat between stem and bonnet . . . removed from heat and pressure media.
- J** **bonnet** — high tin bronze provides long wearing threads.
- k** **packing** — formed ring graphite lubricated . . . packing space exceptionally deep.
- l** **handwheel** — malleable iron . . . hexagon shaped for easy grip . . . air cooled construction.

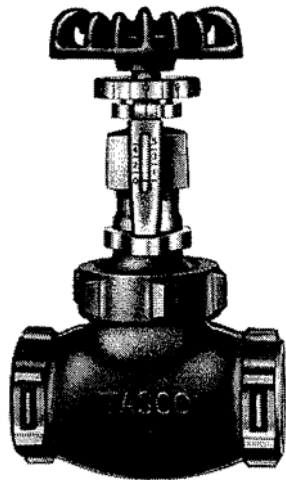
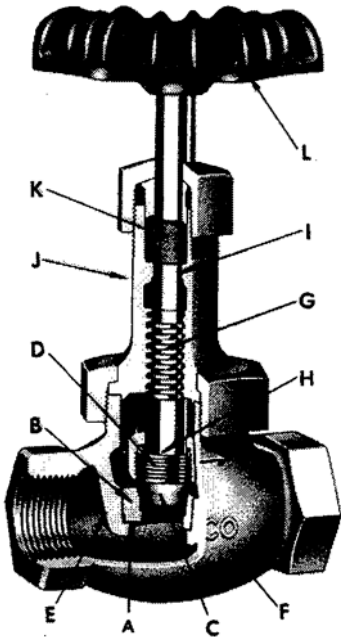

Flocontrol

The TASCO Flocontrol Valve is a combination valve and flow control instrument equipped with a special micrometer dial and pointer which enables the operator to set the valve opening to within one hundredth of a turn of the handwheel. Any desired setting can be instantly duplicated; each valve is fitted with a scientifically designed V-port valve disc, insuring proportional flow throughout the entire lift of the stem. A hand-operated valve with a straight-line flow characteristic with a separate shut-off seating surface removed from the controlling V-Ports, the necessity of using a second valve for shut-off purposes is eliminated. TASCO Flocontrol Valves insure uniform quality by closer control of temperature and flow, save steam and fuel on process work and save money by reducing maintenance.

plus-valves

LOWER MAINTENANCE COSTS — The outstanding record of lower maintenance costs of TASC0 "500 Brinell" Bronze Valves is due to superhard stainless steel seats and discs. These seats and discs cannot wire-draw or steam-cut. Leaky valves are eliminated and maintenance costs are kept at a minimum.

LOWER OPERATING COSTS — Ease of operation in the TASC0 "500 Brinell" Bronze Valve means lower operating costs. The disc assembly design makes it possible to remove the disc and disc nut from the stem without taking the stem from the bonnet. The valve can be repacked under pressure.

HIGHER EFFICIENCY — A major factor in the higher efficiency of TASC0 "500 Brinell" Bronze Valves is the rigid body bonnet and bonnet ring of durable steam bronze. Higher operating efficiency is attained with these features of TASC0 Bronze Valves than with any other valves.

SATISFACTION — The outstanding record of performance by TASC0 "500 Brinell" Bronze Valves is well known to thousands of valve users throughout the country. Experience, research, engineering skill and production are combined to provide the best bronze valves in service today.

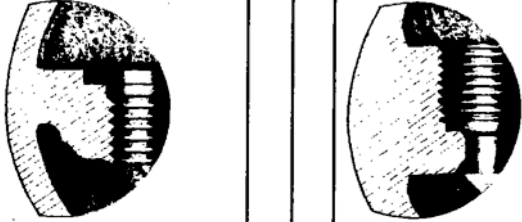
usual bronze valve diaphragm	TASC0 bronze valve diaphragm
<p>125% TO 230% STRONGER DIAPHRAGM — Compare the diaphragm construction of the TASC0 "500 Brinell" Bronze Valve with that of an ordinary bronze valve. Its extra rugged construction means greater ability to withstand expansions in piping systems and strains from installation and piping.</p>	

How the TASC0 Flocontrol valve operates...

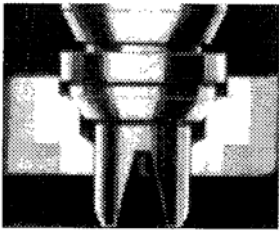
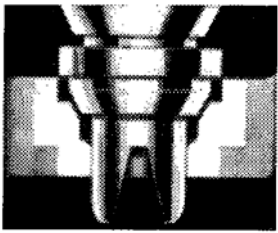
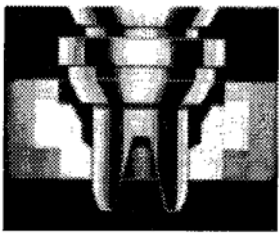
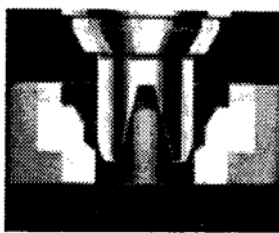
			
<p>Valve seat and V-Port disc in fully closed position. Pressure is pushing upward under the disc. Note that the shut-off seating surface is entirely removed and separate from the flow-controlling V-Ports.</p>	<p>The valve in a slightly opened position. V-Port disc is allowing a measured flow of the media.</p>	<p>In this intermediate position, V-Port disc is allowing a proportionally greater flow of the media.</p>	<p>Valve fully opened allowing maximum flow. Any open position can be accurately duplicated by the use of the special micrometer dial and pointer.</p>

type			non-shock pressure/ temperature ratings	valve sizes — inches								
globe	angle	ends		1/4	3/8	1/2	3/4	1	1 1/4	1 1/2	2	
4420	4430	screwed	150 psi @ 358°F WSP 300 psi @ 100°F WOG	C	2 3/8	2 3/8	2 5/8	3	3 3/4	4 3/8	4 3/4	6
				E	4 3/32	4 3/32	4 11/16	5 1/8	6 1/4	7 3/32	8 13/16	10 3/16
				F	3 23/32	3 23/32	4 3/8	5 1/8	5 7/8	6 13/32	8 1/8	9 3/8
4620	4630		200 psi @ 500°F WSP 400 psi @ 100°F WOG	C	2 3/8	2 3/8	2 5/8	3	3 3/4	4 3/8	4 3/4	6
				E	4 1/4	4 1/4	5 1/8	6 3/32	6 13/16	7 3/4	9	10 1/8
				F	4	4	4 7/8	5 1/2	6 3/8	7 3/8	8 3/8	9 1/8
4584 4582	4594 4592		300 psi @ 550°F WSP 600 psi @ 100°F WOG	C	2 3/8	2 1/2	2 7/8	3 3/8	4 1/8	4 7/8	5 1/4	6 3/8
				E	5 1/8	5 1/8	5 1/8	6 13/32	8 23/32	8 11/16	9 21/32	11 11/32
				F	4 5/8	4 3/8	5 1/4	6 5/32	8 11/32	8 1/8	8 23/32	10 3/8
4445	4455		150 psi @ 358°F WSP 300 psi @ 100°F WOG	C	2 3/8	2 3/8	2 5/8	3	3 3/4	4 3/8	4 3/4	6
		E		4 3/32	4 3/32	4 11/16	5 1/8	6 1/4	7 3/32	8 13/16	10 3/16	
		F		3 23/32	3 23/32	4 3/8	5 1/8	5 7/8	6 13/32	8 1/8	9 3/8	
4585 4586*	4595 4596*	300 psi @ 550°F WSP 600 psi @ 100°F WOG	C	2 3/8	2 1/2	2 7/8	3 3/8	4 1/8	4 7/8	5 1/4	6 3/8	
			E	5 1/8	5 1/8	5 1/8	6 13/32	8 23/32	8 11/16	9 21/32	11 11/32	
			F	4 5/8	4 3/8	5 1/4	6 5/32	8 11/32	8 1/8	8 23/32	10 3/8	

* 2 v port sizes 1/4" thru 3/4" only

NOTE: These are key dimensions only; complete dimensions are shown on pages 6-7

materials

fig. no.	type	ends	body	bonnet	bonnet ring	stem	disc	seat	hand wheel
4420	globe	screwed	bronze ASTM B-62	bronze ASTM B-62	bronze ASTM B-62	silicon brass	stain. steel 13% chrome 500 Brinell	stain. steel 13% chrome 500 Brinell	malleable iron
4430	angle								
4620	globe		bronze ASTM B-61	bronze ASTM B-61	bronze ASTM B-61				
4630	angle								
4584	globe		bronze ASTM B-62	bronze ASTM B-62	bronze ASTM B-62				
4594	angle								
4582	globe		bronze ASTM B-61	bronze ASTM B-61	bronze ASTM B-61				
4592	angle								
4445	globe		bronze ASTM B-61	bronze ASTM B-61	bronze ASTM B-61				
4455	angle								
4585	globe	bronze ASTM B-61	bronze ASTM B-61	bronze ASTM B-61					
4595	angle								
4586	globe								
4596	angle								

valve weights
in pounds

fig. no.	valve sizes — inches								
	1/4	3/8	1/2	3/4	1	1 1/4	1 1/2	2	
4420/4430	1	1	1 3/8	2	3	4 3/8	7 1/2	12 3/8	
4620/4630	1 1/4	1 1/4	1 3/8	2 1/4	3 1/2	5 3/8	8 3/8	13 3/8	
4584/4594 4582/4592	1 1/2	1 1/2	2 1/4	3 3/4	5 3/4	8 3/4	11 1/2	19 1/2	
4445/4455	1 1/8	1 1/8	1 1/2	2 1/8	3 1/2	5 1/2	7 3/4	13	
4585/4595 4586/4596	1 1/2	1 1/2	2 1/4	3 3/4	6	9 3/8	11	20	

dimensions

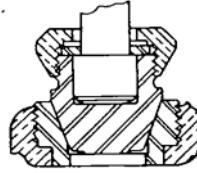

4582 globe
4592 angle

CONE SEAT

4420 globe
4430 angle

4584 globe
4594 angle

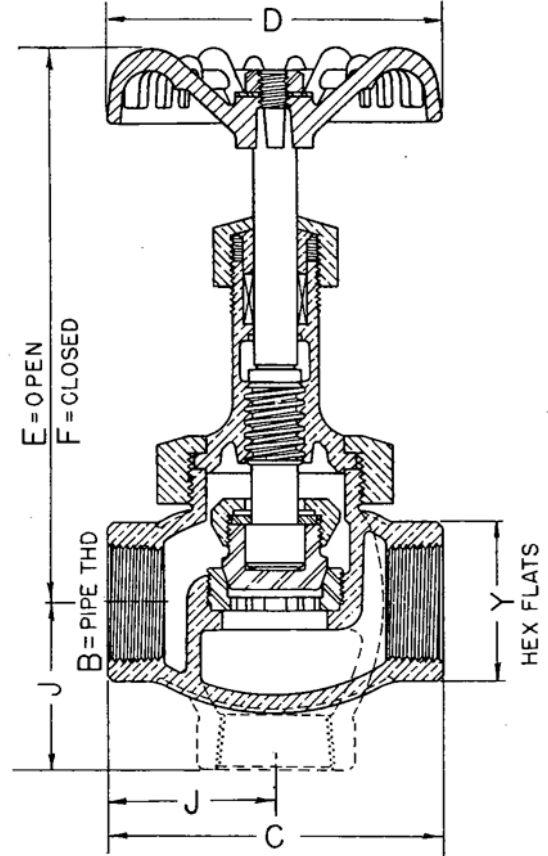
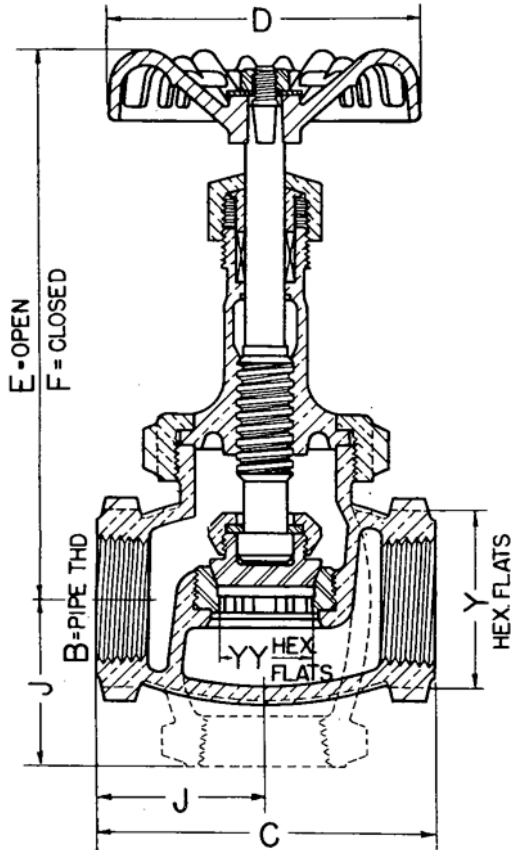

4420 globe
4430 angle

4445 globe
4455 angle

4582 globe
4592 angle

4584 globe
4594 angle

Size	B	C	D	E	F	J	Y	YY*
1/4	1/4	2 3/8	2 1/4	4 7/32	3 29/32	1 1/16	1	.318
3/8	3/8	2 3/8	2 1/4	4 7/32	3 29/32	1 1/16	1	.318
1/2	1/2	2 5/8	2 1/2	4 1 1/16	4 3/8	1 1/16	1 1/4	.385
3/4	3/4	3	2 1 1/16	5 5/16	5 5/16	1 1/2	1 1/16	.510
1	1	3 3/4	3	6 1/4	5 7/8	1 7/8	1 3/4	.697
1 1/4	1 1/4	4 3/8	3 3/16	7 7/32	6 1 1/32	2 3/16	2 1/8	.885
1 1/2	1 1/2	4 3/4	4 3/8	8 1 3/16	8 1/16	2 3/8	2 1/2	1.135
2	2	6	4 7/8	10 3/16	9 3/16	3	3	1.510

*applies to 4420, 4430 valves.

Size	B	C	D	E	F	J	Y
1/4	1/4	2 3/16	2 1 1/16	5 5/16	4 5/8	1 1/32	7/8
3/8	3/8	2 1/2	2 1 1/16	5 5/16	4 5/8	1 1/4	1 1/16
1/2	1/2	2 7/8	3	5 5/16	5 1/4	1 1/16	1 1/4
3/4	3/4	3 3/16	3 1/16	6 1 1/32	6 3/32	1 29/32	1 17/32
1	1	4 1/8	4 3/8	8 29/32	8 1 1/32	2 1/16	1 7/8
1 1/4	1 1/4	4 7/8	4 7/8	8 1 1/16	8 1/16	2 1/16	2 3/16
1 1/2	1 1/2	5 1/4	5 5/16	9 29/32	8 29/32	2 5/8	2 5/8
2	2	6 1/16	5 1 1/16	11 1 1/32	10 5/16	3 3/32	3 3/16

4445 globe
4455 angle } 4 V port

4585 globe
4595 angle } 4 V port
4586 globe
4596 angle } 2 V port

4620 globe
4630 angle

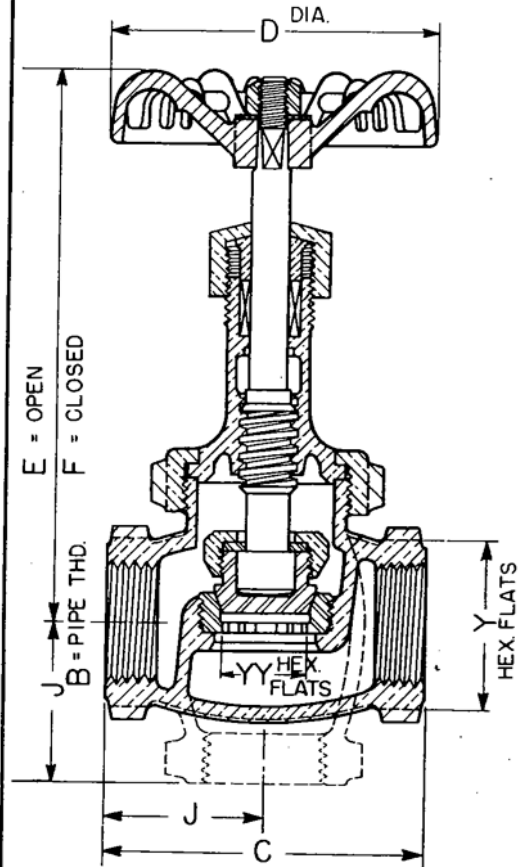
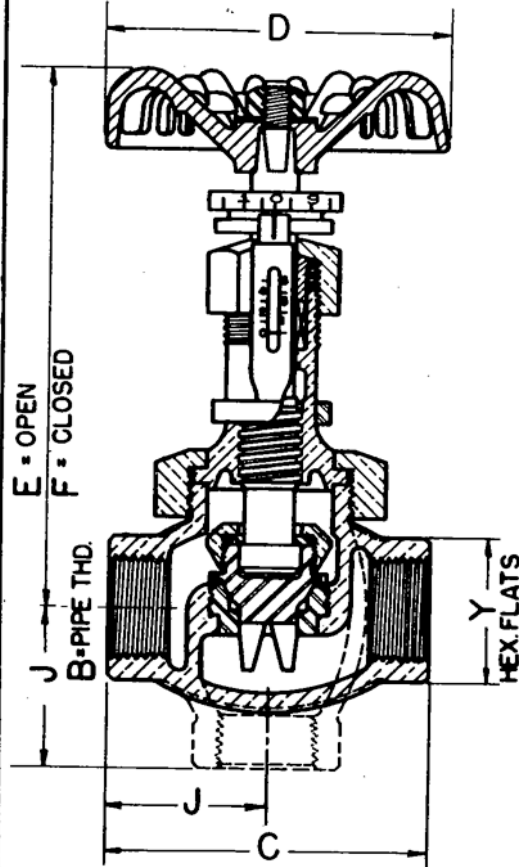
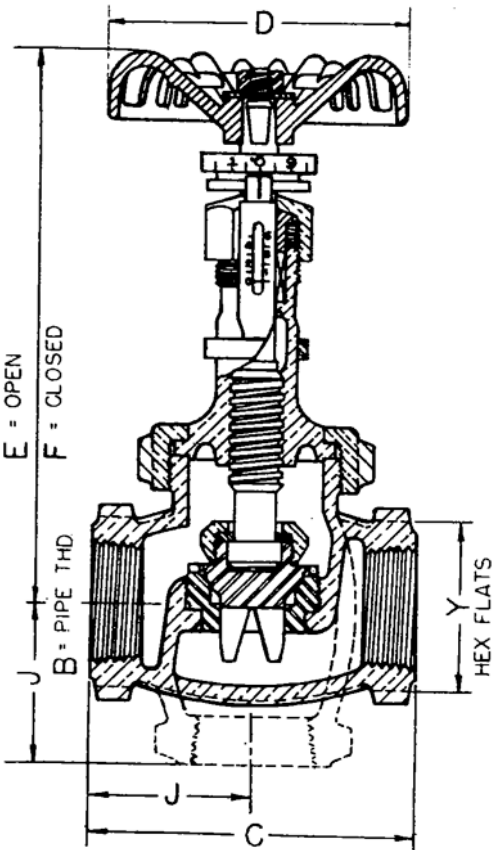

4586 globe
4596 angle

4585 globe
4595 angle

4620 globe
4630 angle

Size	B	C	D	E	F	J	Y
1/4	1/4	2 5/16	2 13/16	5 5/16	4 3/8	1 3/32	7/8
3/8	3/8	2 1/2	2 13/16	5 5/16	4 3/8	1 1/4	1 1/16
1/2	1/2	2 7/8	3	5 5/16	5 1/4	1 1/16	1 1/4
3/4	3/4	3 3/16	3 3/16	6 19/32	6 5/32	1 25/32	1 17/32
1	1	4 1/8	4 3/8	8 23/32	8 11/32	2 1/16	1 7/8
1 1/4	1 1/4	4 7/8	4 7/8	8 11/16	8 1/16	2 1/16	2 5/16
1 1/2	1 1/2	5 1/4	5 5/16	9 23/32	8 23/32	2 5/8	2 5/8
2	2	6 3/16	5 13/16	11 11/32	10 3/16	3 3/32	3 3/16

Size	B	C	D	E	F	J	Y	YY*
1/4	1/4	2 3/8	2 1/2	4 1/4	4	1 3/16	1	.318
3/8	3/8	2 3/8	2 1/2	4 1/4	4	1 3/16	1	.318
1/2	1/2	2 3/8	2 13/16	5 5/16	4 7/8	1 3/16	1 1/4	.385
3/4	3/4	3	3	6 3/32	5 1/2	1 1/2	1 1/16	.510
1	1	3 3/4	3 3/16	6 13/16	6 3/8	1 7/8	1 3/4	.697
1 1/4	1 1/4	4 3/8	4 3/8	7 3/4	7 3/16	2 3/16	2 1/8	.885
1 1/2	1 1/2	4 3/4	4 7/8	9	8 3/8	2 3/8	2 1/2	1.135
2	2	6	5 5/16	10 3/8	9 3/8	3	3	1.510

*applies to 4620, 4630 valves.

bronze — globe and angle

• 150-600 psi • 1/4" - 2"

TASCO valves

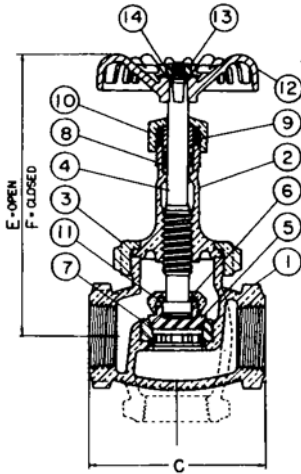

4420 globe
4430 angle

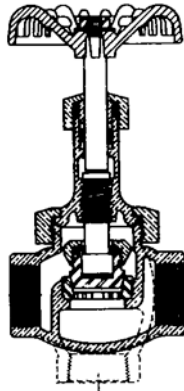

4584 globe
4594 angle



4582 globe
4592 angle

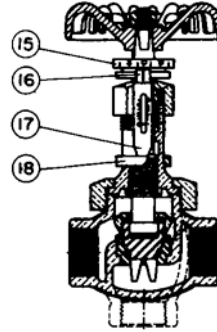

4445 globe
4455 angle
4585 globe } 4 V port
4595 angle }
4586 globe } 2 V port
4596 angle }

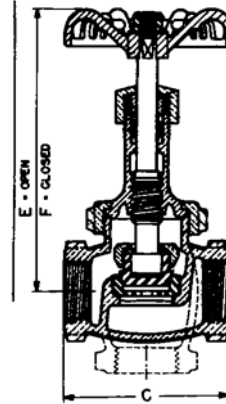

4620 globe
4630 angle

- 1 body
- 2 bonnet
- 3 bonnet ring
- 4 stem
- 5 disc
- 6 disc nut
- 7 seat
- 8 packing ring
- 9 packing gland
- 10 packing nut
- 11 lock ring
- 12 handwheel
- 13 handwheel nut
- 14 marker plate
- 15 dial
- 16 indicator
- 17 indicator tube
- 18 collar

construction

non-shock pressure/ temperature ratings	inside screw rising stem	disc				seat, renewable	rising hand- wheel	hand- wheel vented	type	fig. no.
		plug	cone	4 v port	2 v port					
150 psi @ 358°F WSP 300 psi @ 100°F WOG	●	●				●	●	●	globe	4420
			angle	4430						
200 psi @ 500°F WSP 400 psi @ 100°F WOG	●	●				●	●	●	globe	4620
			angle	4630						
300 psi @ 500°F WSP 600 psi @ 100°F WOG	●	●				●	●	●	globe	4584
			angle	4594						
			globe	4582						
			angle	4592						
150 psi @ 358°F WSP 300 psi @ 100°F WOG	●				●	●	●	●	globe	4445
			angle	4455						
300 psi @ 550°F WSP 600 psi @ 100°F WOG	●				●	●	●	●	globe	4585
			angle	4595						
			globe	4586						
			angle	4596						

* 2 v port in sizes 1/4" thru 3/4" only
NOTE: All Bronze Valves have screwed ends.

Capacity tables and correction factors—TASCO Flocontrol Valves

capacities of 150# bronze flocontrol valves

valve size inches	flow coefficient Cv note 4	hand wheel turns full open	relative capacity % of 1" valve full open	capacity full open		
				water G.P.H. at 10# P.D. note 1	steam lbs. per hr. at 100# abs. note 2	air S.C.F.M. at 100# ga. 70°F. note 3
¼	.23	1.5	8.	44	40	15
⅜	.5	1.5	12.	87	81	30
½	1.2	1.87	29.	306	283	100
¾	2.1	2.5	50.	407	380	140
1	4.2	3.0	100.	780	735	260
1¼	7.3	4.0	174.	1140	1060	380
1½	11.9	5.12	283.	2210	2050	745
2	15.3	5.36	370.	2870	2660	970

For steam, air and gas, if the outlet pressure is greater than 55% of the inlet pressure, see Chart #1 for correction factor.

For superheated steam, see Chart #2 for correction factor.

Note 1. Capacities are for 10 lbs. per sq. in. pressure drop across valve. For other conditions, flow is proportional to the square root of the pressure drop.

Note 2. Capacities are for saturated steam at 100 lbs. per sq. in. absolute pressure. For other conditions, flow is proportional to the absolute pressure.

Note 3. Capacities are for air at 70°F. — 100 lbs. per sq. in. gauge. Air flow is proportional to the absolute pressure. For other gases, flow is inversely proportional to the square root of the specific gravity of the gas referred to air = 1.00

$$Q_{Gas} = Q_{Air} \sqrt{\frac{1}{\text{Specific Grav. Gas}}}$$

capacities of 300# bronze flocontrol valves

valve size inches	flow coefficient Cv note 4	hand wheel turns full open	relative capacity % of 1" valve full open	capacity full open		
				water G.P.H. at 10# P.D. note 1	steam lbs. per hr. at 100# abs. note 2	air S.C.F.M. at 100# ga. 70°F. note 3
¼	.4	1.25	5.8	75	70	25
⅜	1.0	1.85	14.5	180	160	60
½	2.0	2.0	29.	370	350	120
¾	4.0	3.0	58.	750	700	250
1	7.0	4.0	100.	1310	1220	440
1¼	10.4	4.5	150.	1960	1830	660
1½	14.0	5.4	200.	2620	2450	875
2	25.3	6.2	360.	4700	4400	1580

Capacities shown are for 4V-Port valves. 2V-Port valves, furnished in sizes ¼" to ¾" only, will have ½ capacity.

For steam, air and gas, if the outlet pressure is greater than 55% of the inlet pressure, see Chart #1 for correction factor.

For superheated steam, see Chart #2 for correction factor.

Note 4. Cv or flow coefficient is the number of G.P.M. of water which will flow through a given valve when the pressure drop is one psi. It may be used in conjunction with the following formula for sizing Flocontrol valves for water or other non-viscous liquids.

$$\text{Flow coefficient } Cv = \frac{Q \times \sqrt{G}}{\sqrt{H}}$$

Q = G.P.M.

H = Pressure drop psi.

G = Specific gravity compared with water = 1

Correction factors—for Hi-Pressure Drop Valves and Flocontrol Valves

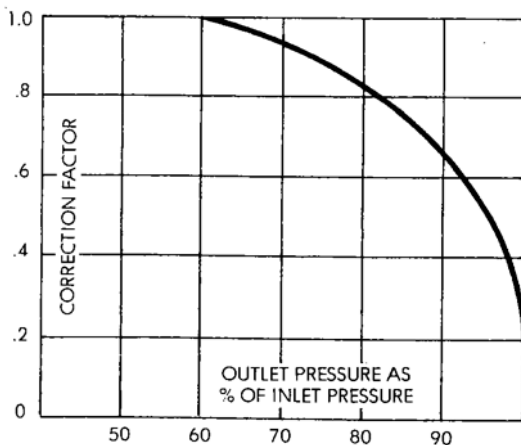

chart #1
steam, air and gas

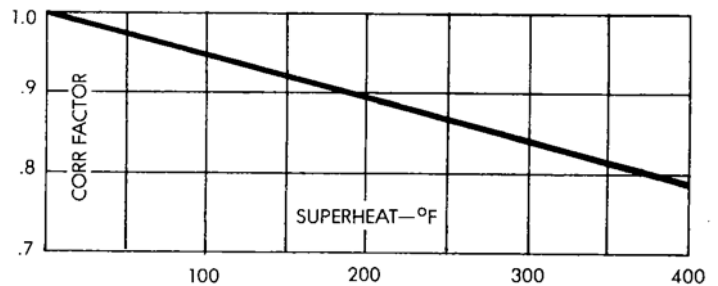
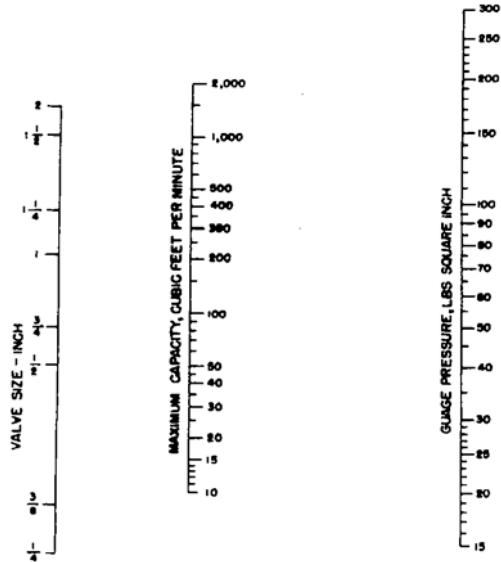

chart #2
steam

Flow charts—TASCO 150# Bronze Flocontrol Valves

air flow chart
fig. nos. 4445 & 4455



For air at 70°F. For other gases, divide capacity by square root of specific gravity. If outlet pressure is greater than 55% of the inlet pressure, multiply capacity by the correction factor on page 8, Chart #1.

steam flow chart
fig. nos. 4445 & 4455

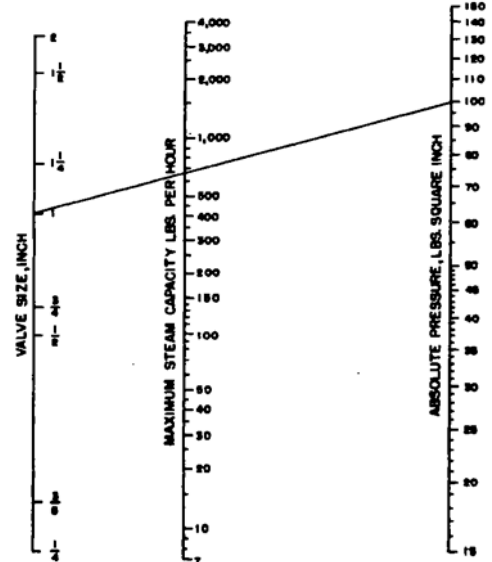

If outlet pressure is greater than 55% of the inlet pressure, multiply capacity by correction factor on page 8. Chart #1.

boiler blowdown chart
TASCO angle flocontrol valves
fig. no. 4455

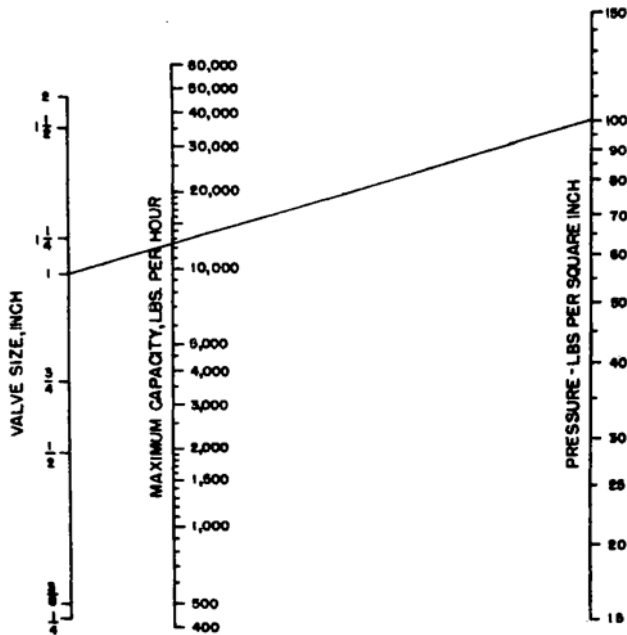

water flow chart
fig. nos. 4445 & 4455

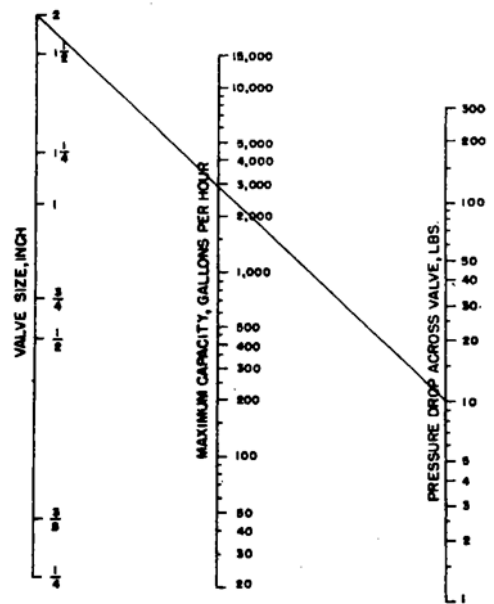

Flow charts—TASCO 300# Bronze Flocontrol Valves

air flow chart #1
300# bronze — fig. nos. 4585 & 4595

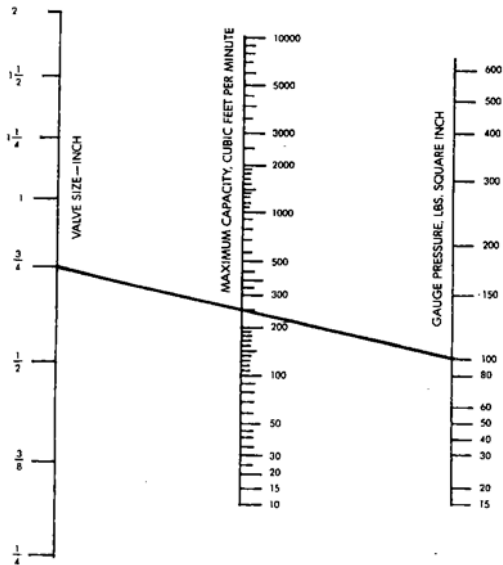

For air at 70°F. only. For other gases divide capacity by square root of specific gravity. If outlet pressure is greater than 55% of the inlet pressure, multiply capacity by correction factor on page 8, Chart #1. For superheated steam, multiply by correction factor on page 8, Chart #2. 4 V-Port valves only. 2 V-Port valves have half capacity.

steam flow chart #2
300# bronze — fig. nos. 4585 & 4595

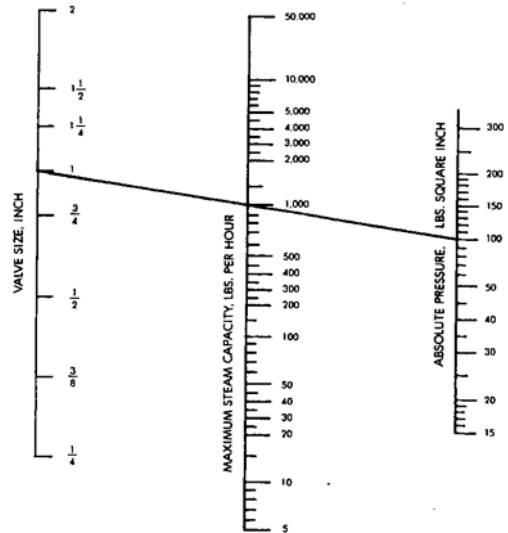

If outlet pressure is greater than 55% of the inlet pressure, multiply capacity by correction factor on page 8, Chart #1. For superheated steam, multiply by correction factor on page 8, Chart #2. 4 V-Port valves only. 2 V-Port valves have half capacity.

water flow chart #3
300# bronze — fig. nos. 4585 & 4595

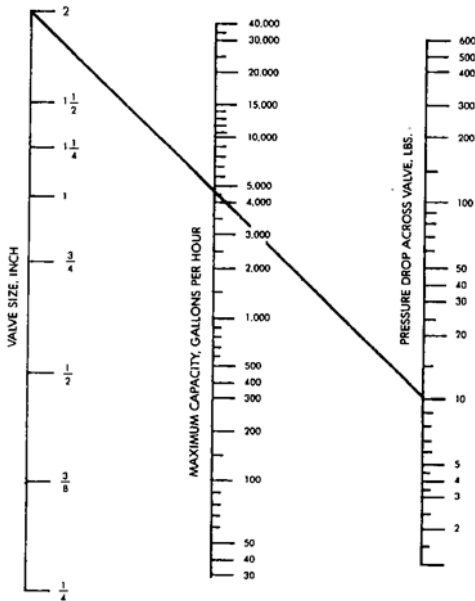

4V-Port valves only. 2V-Port have half capacity.

boiler blowdown chart #4
300# bronze — fig. no. 4595 & 4596

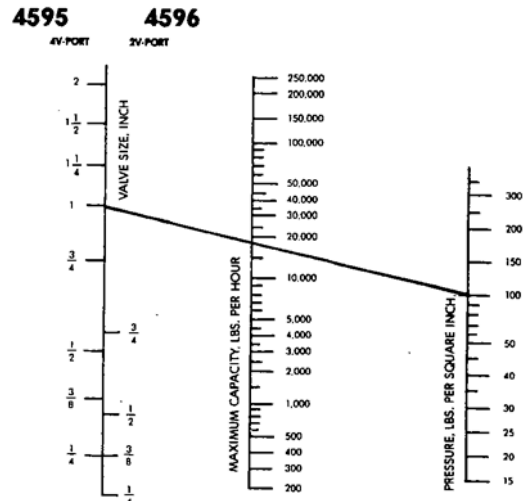

Notes: