



Replacement Parts List

304-366

FI 1511 & 2511

SUPERSEDES: 304-366 March 1, 2012

EFFECTIVE: April 1, 2013

WHEN SELECTING AND ORDERING PARTS, ALWAYS REFER TO SERIAL NUMBER ON NAMEPLATE

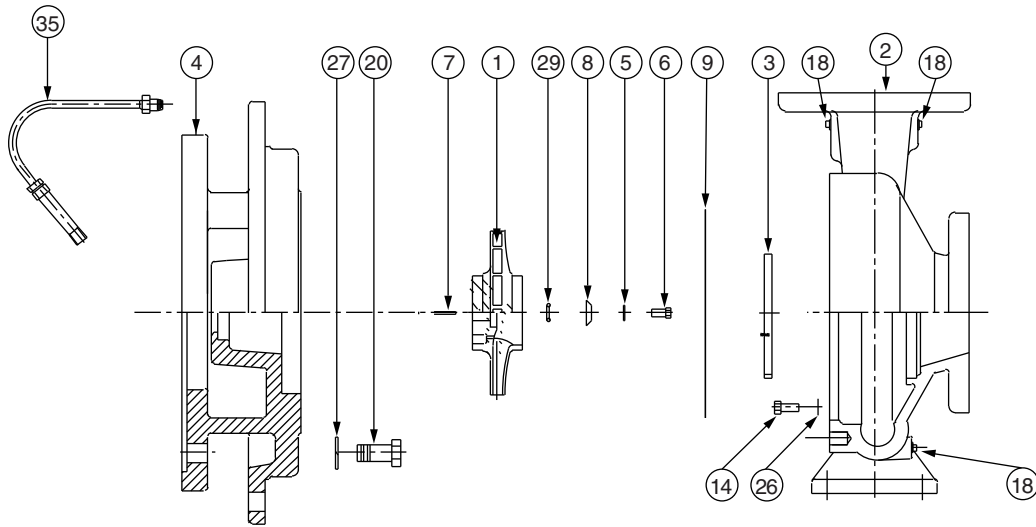
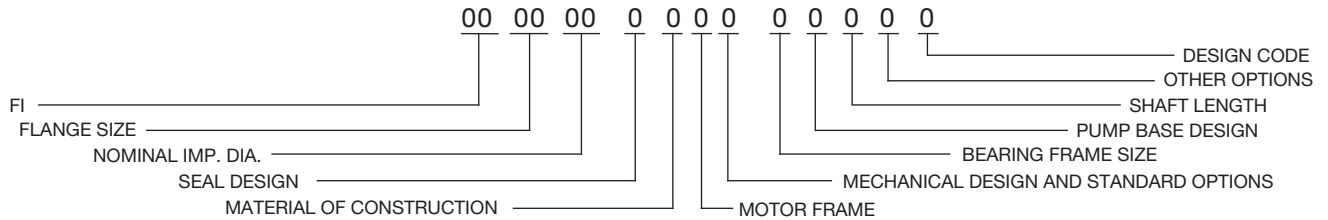

ITEM NO.	NO. REQ.	DESCRIPTION	1511	2511
			BEARING FRAME J	BEARING FRAME J
1	1	IMPELLER (CI)	953-1098RP	953-1205RP
1	1	IMPELLER (BRZ)	953-1089RP	953-1206RP
2	1	CASING (125#)(NO W/R)	953-2403RP*	953-1211RP
2	1	CASING (250#)(NO W/R)	953-2404RP*	953-1250RP
2	1	CASING (125#)(BRZ W/R)	953-2405RP*	953-2318RP
2	1	CASING (250#)(BRZ W/R)	953-2406RP*	953-2319RP
3	1(W/R)	WEAR RING (BRZ)	953-1095RP	953-1212RP
5	1	DOWDY WASHER	951-2579RP	951-2578RP
6	1	IMPELLER BOLT (SST)	1/2NCX1-1/2LG	1/2NCX1-1/2LG
7	1	IMPELLER KEY (SST)	1/4X1/4X2LG	1/4X1/4X2LG
8	1	IMPELLER WASHER	953-829RP	953-828RP
9	1	GASKET (CASING)	953-1010RP	953-1010RP
14	12	CASING BOLT (ST)	1/2NCX1LG	1/2NCX1LG
18	3	PIPE PLUG (BRS)	1/4 NPT	1/4 NPT
26	12	CASING WASHER (ZN)	1/2	1/2
29	1	IMPELLER GASKET	953-759RP	953-759RP
4	1	COVER	953-906RP	953-1215RP
20	4	MOTOR BOLT	1/2NCX1-1/4LG	1/2NCX1-1/4LG
27	4	MOTOR WASHER	1/2	1/2
35	1	TUBE KIT	951-1547RP	951-1547RP

AW-694 REV A

*1511 CASINGS ARE HYDRAULIC DESIGN "B"

FI 'J' Frame Replacement Parts

(for Bearing Frames manufactured after January 2003 – see note below)

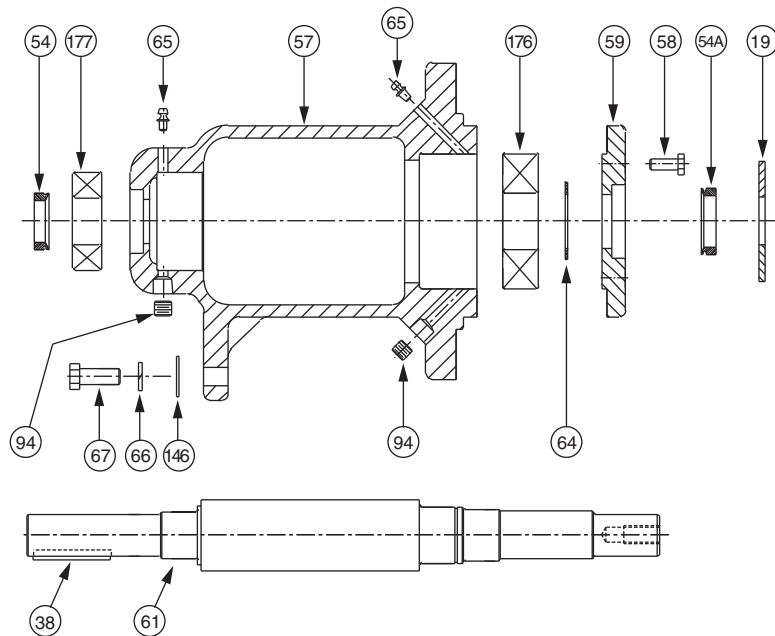

NOTE: Note difference in visual appearance of bearing frames on pages 2 and 3. New frames are a direct replacement for older ones. The part numbers for individual bearings are different from old frames to new frames. If you need help determining which frame you have, please contact tech services at Taco (401-942-8000).

'J' BEARING FRAME

ITEM NO	NO. REQ.	DESCRIPTION	STANDARD SEALED BEARINGS	OPTIONAL GREASEABLE BEARINGS	REMARKS
			PART NO.	PART NO.	
19	1	FRAME ASSEMBLY (CS)	953-2214RP	953-2217RP	CARBON STEEL SHAFT
19	1	FRAME ASSEMBLY (SS)	953-2222RP	953-2223RP	STAINLESS STEEL SHAFT
57	1	HOUSING	953-2203RP	953-2196RP	
61	1	SHAFT (CS)	953-2198RP	953-2198RP	CARBON STEEL
61	1	SHAFT (SS)	953-2199RP	953-2199RP	STAINLESS STEEL
59	1	END CAP	953-2197RP	953-2197RP	
67	1	BOLT, FOOT SUPPORT	10-234RP	10-234RP	
66	1	LOCKWASHER, FOOT SUPPORT	14-102RP	14-102RP	
146	1	FLAT WASHER, FOOT SUPPORT	14-302RP	14-302RP	
38	1	KEY-SHAFT	13-110RP	13-110RP	
176	1	BALL BEARING, FRONT (THRUST)	953-2215RP	950-963RP	
177	1	BALL BEARING, REAR (RADIAL)	951-5599RP	951-2491RP	
19	1	DEFLECTOR	951-3040RP	951-3040RP	
64	1	RETAINING RING	15-140RP	15-140RP	
58	4	HEX HD BOLT-END CAP	10-207RP	10-207RP	
54	1	V RING SEAL-REAR	953-1575-3RP	953-1575-3RP	
54A	1	V RING SEAL-FRONT	953-1575-3RP	953-1575-3RP	
65	2	GREASE FITTING	-----	15-203RP	
94	2	PIPE PLUG	-----	16-140RP	

AW-717 REV D

FI 'J' Frame Replacement Parts

(for Bearing Frames manufactured prior to February 2003 – see note below)

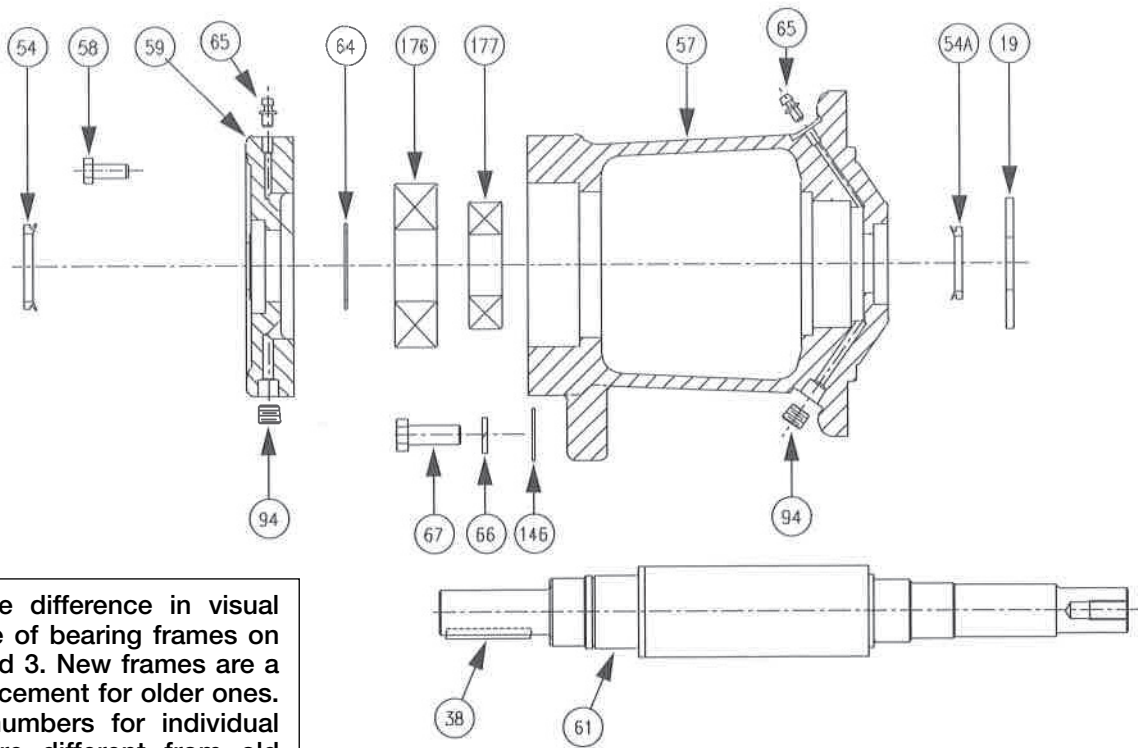

NOTE: Note difference in visual appearance of bearing frames on pages 2 and 3. New frames are a direct replacement for older ones. The part numbers for individual bearings are different from old frames to new frames. If you need help determining which frame you have, please contact tech services at Taco (401-942-8000).

ITEM NO	NO. REQ.	DESCRIPTION	STANDARD SEALED BEARINGS	OPTIONAL GREASEABLE BEARINGS	REMARKS
			PART NO.	PART NO.	
19	1	FRAME ASSEMBLY (CS)	953-1571RP	953-1880RP	CARBON STEEL SHAFT
19	1	FRAME ASSEMBLY (SS)	953-1572RP	953-1881RP	STEEL STEEL SHAFT
57	1	HOUSING	953-1565RP	953-1866RP	
61	1	SHAFT (CS)	953-1658RP	953-1658RP	CARBON STEEL
61	1	SHAFT (SS)	953-1663RP	953-1663RP	STEEL STEEL
59	1	END CAP	953-1567RP	953-1869RP	
67	1	BOLT-FOOT SUPPORT	10-234RP	10-234RP	
66	1	LOCKWASHER-FOOT SUPPORT	14-102RP	14-102RP	
146	1	FLAT WASHER-FOOT SUPPORT	14-302RP	14-302RP	
38	1	KEY-SHAFT	13-110RP	13-110RP	
176	1	BALL BEARING-REAR (THRUST)	953-1871RP	951-155RP	
177	1	BALL BEARING-FRONT (RADIAL)	953-1876RP	862-101RP	
19	1	DEFLECTOR	951-3040RP	951-3040RP	
64	1	RETAINING RING	15-127RP	15-127RP	
58	4	HEX HD BOLT-END CAP	10-227RP	10-227RP	
54	1	V RING SEAL-REAR	953-1575-3RP	953-1575-3RP	
54A	1	V RING SEAL-FRONT	953-1575-4RP	953-1575-4RP	
65	2	GREASE FITTING	-----	15-203RP	
94	2	PIPE PLUG	-----	16-140RP	

FI Series Seal Replacement Parts (EPT)

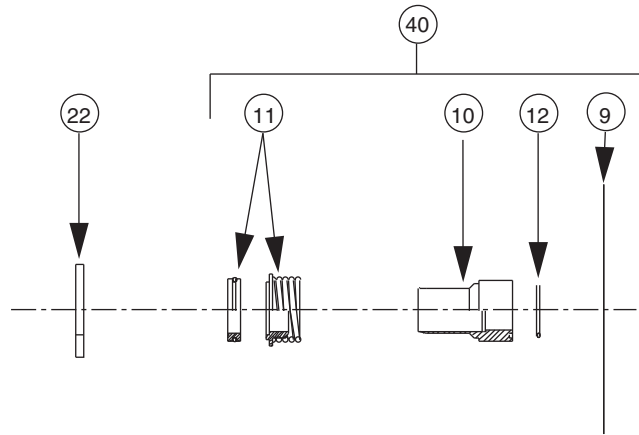

1206, 1506, 2506			1206, 1506, 2506		
1207, 1507, 2007	2507, 3007, 4075, 4007, 5007		1207, 1507, 2007	2507, 3007, 4075, 4007, 5007	
	2508			2508	
1209C, 2009C, 2509C	1509, 2009, 2009C, 2509, 2509C, 3009, 4009, 5009, 5095, 6009		1209C, 2009C, 2509C	1509, 2009, 2009C, 2509, 2509C, 3009, 4009, 5009, 5095, 6009	
2510C	2510		2510C	2510	
	1511, 2511, 3011, 4011, 4011C, 5011, 6011			1511, 2511, 3011, 4011, 4011C, 5011, 6011	
	2513, 3013, 4013	5013, 6013		2513, 3013, 4013	5013, 6013

ITEM NO.	NO. REQ.	DESCRIPTION	BEARING FRAME			BEARING FRAME		
			H	J	L	H	J	L
			MECHANICAL DESIGN (125#)			MECHANICAL DESIGN (250#)		
9	1	GASKET (CASING)	SEE PAGE 1	SEE PAGE 1	SEE PAGE 1	SEE PAGE 1	SEE PAGE 1	SEE PAGE 1
10	1	SLEEVE (SS)	953-1118RP	953-1170RP	953-1172RP	953-1892RP	953-1891RP	953-1890RP
10	1	SLEEVE (BRZ)	953-1119RP	953-1171RP	953-1173RP	953-1861RP	953-1887RP	953-1888RP
11	1	SEAL (TYPE B)	951-3157RP	951-3158RP	951-2966RP	951-3766RP	951-5158RP	951-5151RP
11	1	SEAL (TYPE D)	951-3159RP	951-3160RP	951-2967RP	951-3781RP	951-5159RP	951-5152RP
11	1	SEAL (TYPE E)	951-3161RP	951-3162RP	951-2968RP	951-3782RP	951-5160RP	951-5153RP
12	1	SLEEVE "O"-RING	592-525RP	951-3042RP	951-5277RP	592-525RP	951-3042RP	951-5277RP
22	1	DEFLECTOR	900-043RP	951-3040RP	951-3065RP	900-043RP	951-3040RP	951-3065RP
40	1	SEAL KIT (TYPE B) SS	953-1549-1RP	953-1549-4RP	953-1549-14RP	953-1549-7RP	953-1549-10RP	953-1549-17RP
40	1	SEAL KIT (TYPE B) BRZ	953-1549-1BRP	953-1549-4BRP	953-1549-14BRP	953-1549-7BRP	953-1549-10BRP	953-1549-17BRP
40	1	SEAL KIT (TYPE D) SS	953-1549-2RP	953-1549-5RP	953-1549-15RP	953-1549-8RP	953-1549-11RP	953-1549-18RP
40	1	SEAL KIT (TYPE D) BRZ	953-1549-2BRP	953-1549-5BRP	953-1549-15BRP	953-1549-8BRP	953-1549-11BRP	953-1549-18BRP
40	1	SEAL KIT (TYPE E) SS	953-1549-3RP	953-1549-6RP	953-1549-16RP	953-1549-9RP	953-1549-12RP	953-1549-19RP
40	1	SEAL KIT (TYPE E) BRZ	953-1549-3BRP	953-1549-6BRP	953-1549-16BRP	953-1549-9BRP	953-1549-12BRP	953-1549-19BRP

AW-698 REV J

Motor Replacement Parts

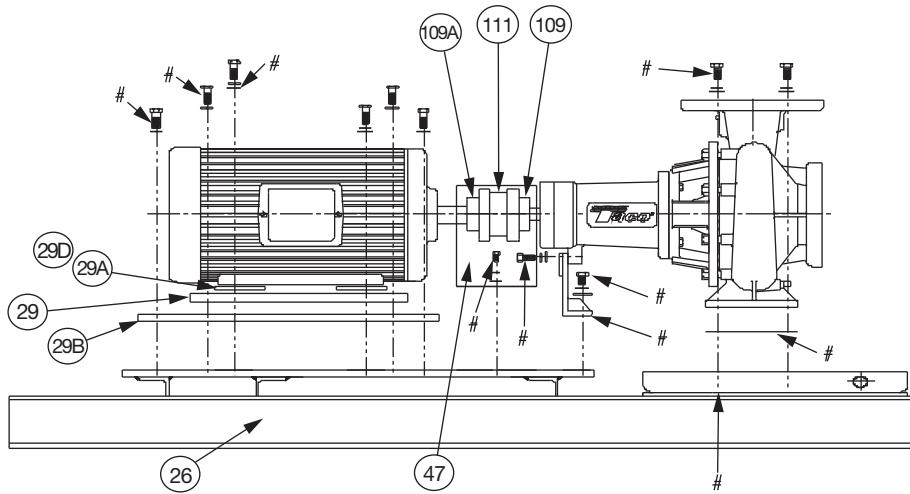

SEE FI BASE HARDWARE SPREAD SHEET FOR ALL PUMPS

NOTE: INCLUDE 'RP' AT END OF P/N

ITEM NO.	NO. REQ.	DESCRIPTION	FI 1511 MOTOR FRAMES (NEMA STD.) "T"										
			143T	145T	182T	184T	213T	215T	254T	256T	284T	286T	
47	1	COUPLER GUARD	-	951-3076	951-3076	951-3076	951-3076	951-3076	951-3076	951-3078	-	-	-
109	1	PUMP COUPLER HALF	-	953-2437	953-2437	953-2437	953-2437	953-2437	953-2437	953-2443	-	-	-
109A	1	MTR. COUPLER HALF	-	953-2433	953-2435	953-2435	953-2437	953-2437	953-2445	-	-	-	
111	1	COUPLER INSERT	-	953-2430	953-2430	953-2430	953-2430	953-2430	953-2438	-	-	-	
*	1	OSHA COUPLER GUARD	-	953-1914	953-1914	953-1914	953-1914	953-1914	953-1914	-	-	-	
26	1	BASE	-	953-2368	953-2368	953-2368	953-2368	953-2368	953-2372	-	-	-	
29	2	SPACER (1ST) MOTOR	-	951-5202						-	-	-	
29B	2	SPACER (2ND) MOTOR	-	951-5201						-	-	-	
29A	4	SPACER RD (1ST) MOTOR			953-2228	953-2228			953-2228				

ITEM NO.	NO. REQ.	DESCRIPTION	FI 2511 MOTOR FRAMES (NEMA STD.) "T"									
			143T	145T	182T	184T	213T	215T	254T	256T	284T	286T
47	1	COUPLER GUARD	-	951-3574	951-3574	951-3574	951-3574	951-3574	951-3574	-	-	-
109	1	PUMP COUPLER HALF	-	953-2437	953-2437	953-2437	953-2437	953-2437	953-2443	-	-	-
109A	1	MTR. COUPLER HALF	-	953-2433	953-2435	953-2435	953-2437	953-2437	953-2445	-	-	-
111	1	COUPLER INSERT	-	953-2430	953-2430	953-2430	953-2430	953-2430	953-2438	-	-	-
*	1	OSHA COUPLER GUARD	-	953-1915	953-1915	953-1915	953-1915	953-1915	953-1915	-	-	-
26	1	BASE	-	953-2212	953-2363	953-2363	953-2363	953-2363	953-2363	-	-	-
29	2	SPACER (1ST) MOTOR	-	951-5202	951-5210	951-5210	951-5210	951-5204		-	-	-
29B	2	SPACER (2ND) MOTOR	-	951-5201						-	-	-
29A	4	SPACER RD (1ST) MOTOR							953-2228			

AW-726 REV C



TACO, INC., 1160 Cranston Street, Cranston, RI 02920 Telephone: (401) 942-8000 FAX: (401) 942-2360.
TACO (Canada), Ltd., 8450 Lawson Road, Unit #3, Milton, Ontario L9T 0J8. Telephone: 905/564-9422. FAX: 905/564-9436.
 Visit our web site at: <http://www.taco-hvac.com>

Printed in USA
 Copyright 2013
 TACO, Inc.