



Replacement Parts List

304-401

FI 2007

SUPERSEDES: June 1, 2009

EFFECTIVE: March 1, 2012

WHEN SELECTING AND ORDERING PARTS, ALWAYS REFER TO SERIAL NUMBER ON NAMEPLATE

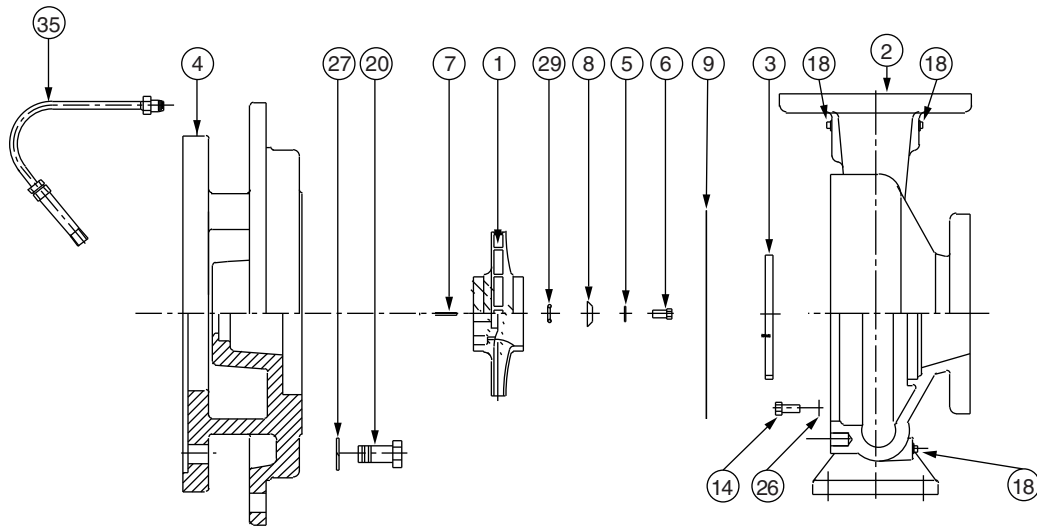
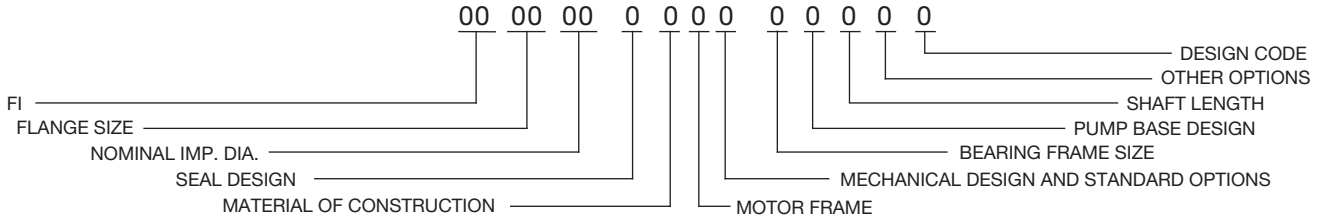

ITEM NO.	NO. REQ.	DESCRIPTION	2007
			BEARING FRAME H
1	1	IMPELLER (CI)	953-2508RP
1	1	IMPELLER (BRZ)	953-2509RP
2	1	CASING (125#)(NO W/R)	953-2502RP
2	1	CASING (250#)(NO W/R)	953-2503RP
2	1	CASING (125#)(BRZ W/R)	953-2506RP
2	1	CASING (250#)(BRZ W/R)	953-2507RP
3	1(W/R)	WEAR RING (BRZ)	953-2510RP
5	1	DOWDY WASHER	951-2578RP
6	1	IMPELLER BOLT (SST)	3/8NC X 1 LG
7	1	IMPELLER KEY (SST)	3/16x3/16x1-1/8LG
8	1	IMPELLER WASHER	953-828RP
9	1	GASKET (CASING)	953-568RP
14	8	CASING BOLT (ST)	3/8NC X 1 LG
18	3	PIPE PLUG (BRS)	1/4 NPT
26	8	CASING WASHER (ZN)	3/8
29	1	IMPELLER GASKET	953-830RP
4	1	COVER	953-2512RP
20	4	MOTOR BOLT	3/8NC X 1LG
27	4	MOTOR WASHER	3/8
35	1	TUBE KIT	951-1547RP

AW-825 REV -

FI 'H' Frame Replacement Parts

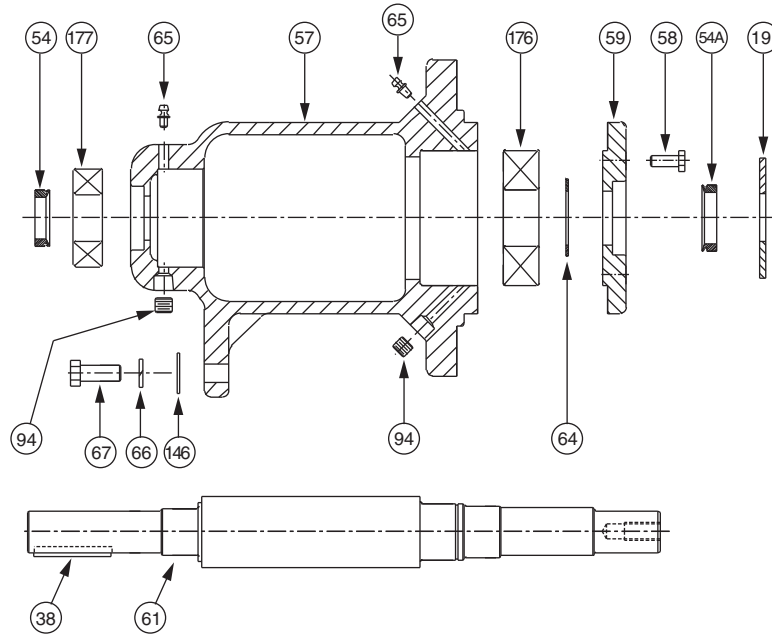

'H' BEARING FRAME

ITEM NO	NO. REQ.	DESCRIPTION	STANDARD SEALED BEARINGS	OPTIONAL GREASEABLE BEARINGS	REMARKS
			PART NO.	PART NO.	
19	1	FRAME ASSEMBLY (CS)	953-2218RP	953-2219RP	CARBON STEEL SHAFT
19	1	FRAME ASSEMBLY (SS)	953-2224RP	953-2225RP	STAINLESS STEEL SHAFT
57	1	HOUSING	953-2205RP	953-2200RP	
61	1	SHAFT (CS)	953-2202RP	953-2202RP	CARBON STEEL
61	1	SHAFT (SS)	953-2204RP	953-2204RP	STAINLESS STEEL
59	1	END CAP	953-2201RP	953-2201RP	
67	1	BOLT, FOOT SUPPORT	10-215RP	10-215RP	
66	1	LOCKWASHER, FOOT SUPPORT	14-101RP	14-101RP	
146	1	FLAT WASHER, FOOT SUPPORT	14-316RP	14-316RP	
38	1	KEY-SHAFT	13-103RP	13-103RP	
176	1	BALL BEARING, FRONT (THRUST)	820-1039RP	820-067RP	
177	1	BALL BEARING, REAR (RADIAL)	953-2216RP	951-2482RP	
19	1	DEFLECTOR	900-043RP	900-043RP	
64	1	RETAINING RING	15-125RP	15-125RP	
58	4	HEX HEAD BOLT, END CAP	10-244RP	10-244RP	
54	1	V RING SEAL, REAR	953-1575-5RP	953-1575-5RP	
54A	1	V RING SEAL, FRONT	953-1575-2RP	953-1575-2RP	
65	2	GREASE FITTING	-----	15-203RP	
94	2	PIPE PLUG	-----	16-140RP	

FI Series Seal Replacement Parts (EPT)

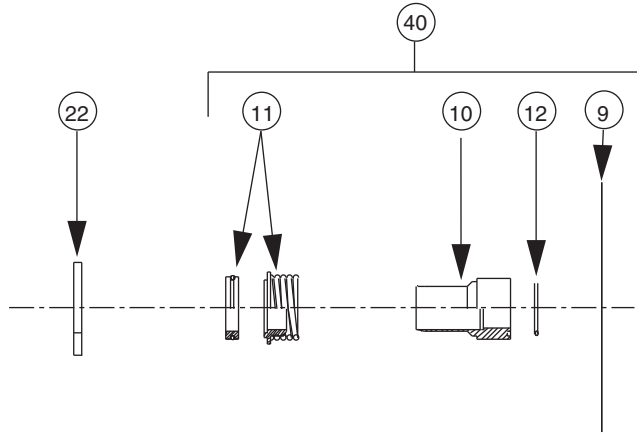

1206, 1506, 2506			1206, 1506, 2506		
1207, 1507, 2007	2507, 3007, 4075, 4007, 5007		1207, 1507, 2007	2507, 3007, 4075, 4007, 5007	
	2508			2508	
	1509, 2009, 2509, 3009, 4009, 5009, 5095, 6009			1509, 2009, 2509, 3009, 4009, 5009, 5095, 6009	
	2510			2510	
	1511, 2511, 3011, 4011, 5011, 6011			1511, 2511, 3011, 4011, 5011, 6011	
	2513, 3013, 4013	5013, 6013		2513, 3013, 4013	5013, 6013

ITEM NO.	NO. REQ.	DESCRIPTION	BEARING FRAME			BEARING FRAME		
			H	J	L	H	J	L
			MECHANICAL DES. (125#)			MECHANICAL DES. (250#)		
9	1	GASKET (CASING)	SEE PAGE 1	SEE PAGE 1	SEE PAGE 1	SEE PAGE 1	SEE PAGE 1	SEE PAGE 1
10	1	SLEEVE (SS)	953-1118RP	953-1170RP	953-1172RP	953-1892RP	953-1891RP	953-1890RP
10	1	SLEEVE (BRZ)	953-1119RP	953-1171RP	953-1173RP	953-1861RP	953-1887RP	953-1888RP
11	1	SEAL (TYPE B)	951-3157RP	951-3158RP	951-2966RP	951-3766RP	951-5158RP	951-5151RP
11	1	SEAL (TYPE D)	951-3159RP	951-3160RP	951-2967RP	951-3781RP	951-5159RP	951-5152RP
11	1	SEAL (TYPE E)	951-3161RP	951-3162RP	951-2968RP	951-3782RP	951-5160RP	951-5153RP
12	1	SLEEVE GASKET	953-830RP	951-3042RP	951-5277RP	953-830RP	951-3042RP	951-5277RP
22	1	DEFLECTOR	900-043RP	951-3040RP	951-3065RP	900-043RP	951-3040RP	951-3065RP
40	1	SEAL KIT (TYPE B) SS	953-1549-1RP	953-1549-4RP	953-1549-14RP	953-1549-7RP	953-1549-10RP	953-1549-17RP
40	1	SEAL KIT (TYPE B) BRZ	953-1549-1BRP	953-1549-4BRP	953-1549-14BRP	953-1549-7BRP	953-1549-10BRP	953-1549-17BRP
40	1	SEAL KIT (TYPE D) SS	953-1549-2RP	953-1549-5RP	953-1549-15RP	953-1549-8RP	953-1549-11RP	953-1549-18RP
40	1	SEAL KIT (TYPE D) BRZ	953-1549-2BRP	953-1549-5BRP	953-1549-15BRP	953-1549-8BRP	953-1549-11BRP	953-1549-18BRP
40	1	SEAL KIT (TYPE E) SS	953-1549-3RP	953-1549-6RP	953-1549-16RP	953-1549-9RP	953-1549-12RP	953-1549-19RP
40	1	SEAL KIT (TYPE E) BRZ	953-1549-3BRP	953-1549-6BRP	953-1549-16BRP	953-1549-9BRP	953-1549-12BRP	953-1549-19BRP

AW-698 REV D

Motor Replacement Parts

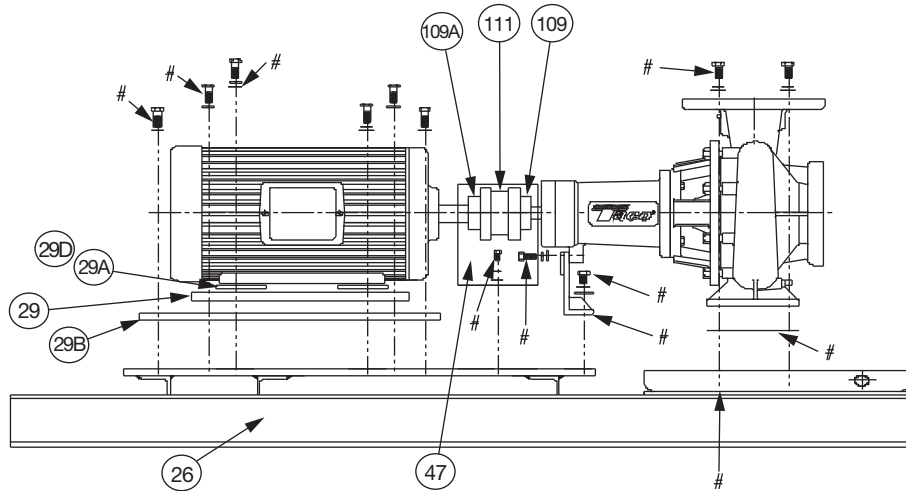

SEE FI BASE HARDWARE SPREAD SHEET FOR ALL PUMPS

NOTE: INCLUDE 'RP' AT END OF P/N

AW-827 REV A

ITEM NO.	NO. REQ.	DESCRIPTION	FI 2007 MOTOR FRAMES (NEMA STD.) "T"										
			56	143T	145T	182T	184T	213T	215T	254T	256T	284T	286T
47	1	COUPLER GUARD	-	951-3075	951-3075	951-3075	951-3075	951-3077	951-3077	951-3077	951-3077	951-3574	-
109	1	PUMP COUPLER HALF	-	953-2427	953-2427	953-2427	953-2427	953-2433	953-2433	953-2439	953-2439	953-2439	-
109A	1	MTR. COUPLER HALF	-	953-2427	953-2427	953-2429	953-2429	953-2437	953-2437	953-2445	953-2445	953-2445	-
111	1	COUPLER INSERT	-	953-2424	953-2424	953-2424	953-2424	953-2430	953-2430	953-2438	953-2438	953-2438	-
*	1	OSHA COUPLER GUARD	-	953-1914	953-1914	953-1914	953-1914	953-1914	953-1914	953-1914	953-1914	953-1915	-
26	1	BASE	-	953-2584	953-2584	953-2584	953-2584	953-2586	953-2586	953-2586	953-2586	953-2592	-
29	2	SPACER (1ST) MOTOR	-	951-5201	951-5201	-	-	-	-	-	-	-	-
29A	4	SPACER RD (1ST) MOTOR	-	-	-	-	-	953-2229	953-2229	-	-	-	-
29C	2	SPACER FOOT SUPPORT	-	-	-	-	-	-	-	-	-	953-5314	-

Do it Once. Do it Right.®

TACO, INC., 1160 Cranston Street, Cranston, RI 02920 Telephone: (401) 942-8000 FAX: (401) 942-2360.

TACO (Canada), Ltd., 8450 Lawson Road, Unit #3, Milton, Ontario L9T 0J8. Telephone: 905/564-9422. FAX: 905/564-9436.

Visit our web site at: <http://www.taco-hvac.com>

Printed in USA

Copyright 2012

TACO, Inc.